

AT/ATR-TH SERIES

AC Current Transducers

AT/ATR-TH Series AC Current Transducers are the latest innovation for monitoring three-phase loads, motors, machines or buildings. The large triple-aperture solid-core design allows for a quick and easy installation. Just thread the conductors through the sensing windows (apertures) and reconnect on the other side. The transducer outputs are powered from an excitation voltage of 24 VAC or DC, or optionally 120 VAC, isolated from the monitored circuit. Three outputs are proportional to the AC current in each phase and a fourth represents the average of the three. Each are available at any time. The sensor mounts on a back panel or a DIN rail and is designed to accommodate wire sizes for loads up to 200 amps.



Current Transducer Applications

Monitor Large Machines

- Detect over or undercurrent conditions before they cause break downs or interlock one process with another.

Water Delivery and Treatment

- Detect open discharge lines.
- Sense clogged filters or blocked intake to pumps.
- Measure increased current to show failing bearings or pump impeller cavitation.

Generators

- Shed noncritical loads when demand reaches a set level.

Load Imbalance

- Monitor motor current draw which should be nearly equal in all three phases. A difference of 10% signifies trouble.

Submersible Pump Application

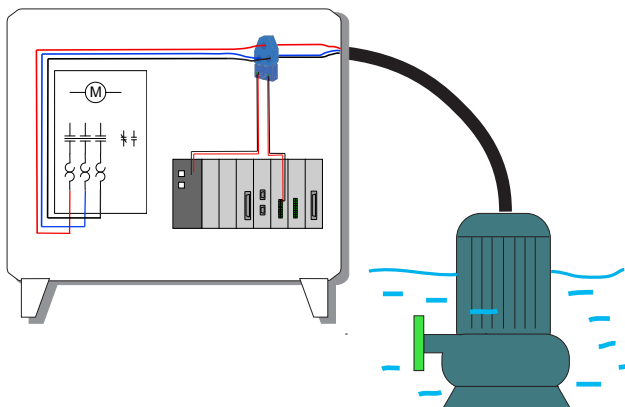

Current Transducer Features

Analog Signal Proportional to AC Current

- Both average responding and True RMS models available.
- Compatible with most automation and control systems.
- One output represents the current in each phase. A fourth produces a signal proportional to the average of the current in all three phases.

Externally Powered

- Simple and reliable connection.

Factory Calibrated and Warranted For Five Years

- Choice of ranges : 0–10 to 0–200 amps.
- Designed for longest life and reliability.

Solid-core Case

- Sensing windows provide ample space for single or multiple conductors per phase.

DIN Rail or Panel Mount

- Snap onto DIN rail or attach with screws to a panel for secure mounting.*

UL/cUL and CE Approved

- Accepted worldwide.

*For information on the DIN rail accessories kit, see page 144.

OEMs

Test & Evaluation Units for OEMs

Free program expedites evaluation process. See page 3 for details.

Current Transducer Dimensions

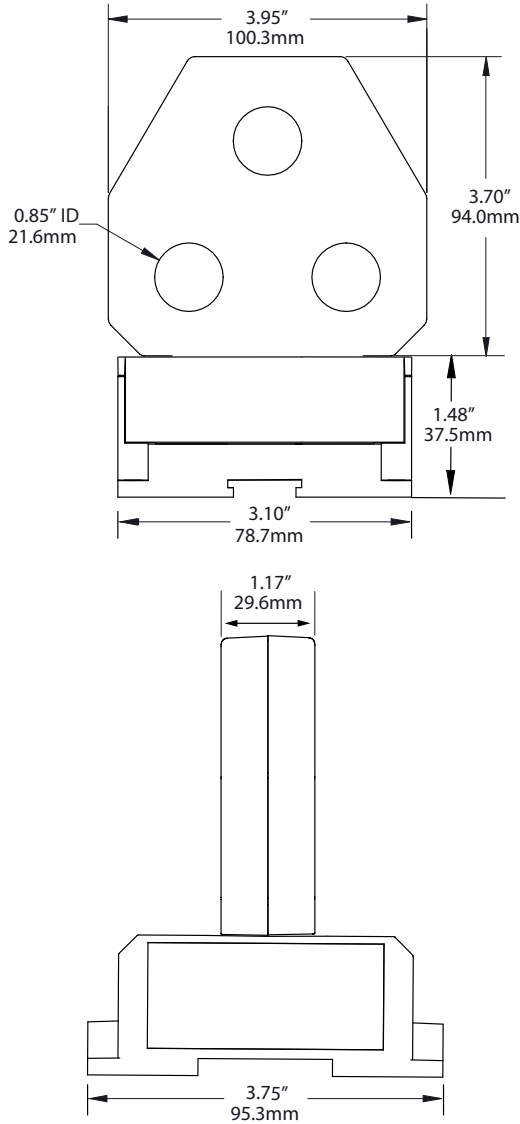

Current Transducer Connections

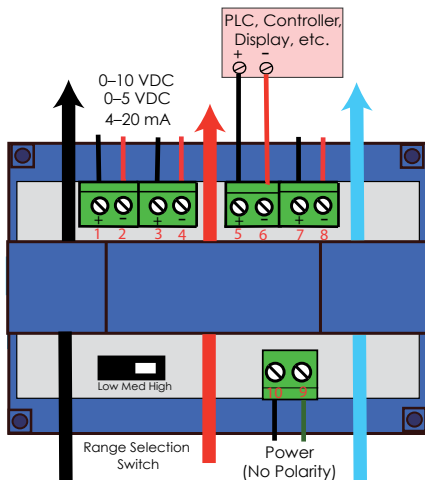

Current Transducer Specifications



Power Supply	<ul style="list-style-type: none"> • 24 VAC/DC (22–28 V) • 120 VAC (108–132 VAC) 						
Power Consumption	<6 VA						
Output	Three Individual analogs proportional to current in each phase, one analog proportional to the average of the three current levels.						
Signal Impedance	<ul style="list-style-type: none"> • 4–20 mA: <500 Ω • 0–5/10 VDC >2K Ω 						
Response Time	220 ms (90% step change)						
Ranges (Range selection made with a slide switch.)	<table border="1"> <tr> <td>1</td> <td>0–10, 15 and 30 A</td> </tr> <tr> <td>2</td> <td>0–30, 50, 100 A</td> </tr> <tr> <td>3</td> <td>0–100, 150, 200 A</td> </tr> </table>	1	0–10, 15 and 30 A	2	0–30, 50, 100 A	3	0–100, 150, 200 A
1	0–10, 15 and 30 A						
2	0–30, 50, 100 A						
3	0–100, 150, 200 A						
Working Voltage	600 VAC						
Frequency Range	50–60 Hz. (Avg.), 30–100 Hz (RMS)						
Case	UL94 V-0 Flammability Rated						
Environmental	-4 to 122°F (-20 to 50°C) 0–95% RH, non-condensing						
Listings	UL/cUL, CE						

AC Current Transducers

Ordering Information

Sample Model Number: ATR2-420-24U-TH, AC RMS current transducer, 0–100 A range, 4–20 mA output, 24 VAC/DC, 3 hole solid-core case, DIN rail mount.

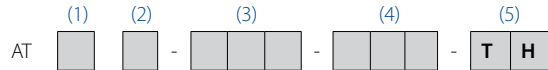

(1) Output Type

	Average responding (blank)
R	True RMS

(2) Range

1	0–10, 15 and 30 A
2	0–30, 50, 100 A
3	0–100, 150, 200 A

(3) Output Type

420	4–20 mA
005	0–5 VDC
010	0–10 VDC

(4) Power Supply

24U	24 VAC/DC externally powered
120	120 VAC externally powered

(5) Case

TH	Three-hole, solid-core, base terminals, DIN rail or panel mount
----	---

