

OPERATING INSTRUCTIONS

MIT / MITH *TwistMate* Connectors

DESCRIPTION: Quick connectors for Female Threads.

PLUG MALE CONNECTOR STYLE

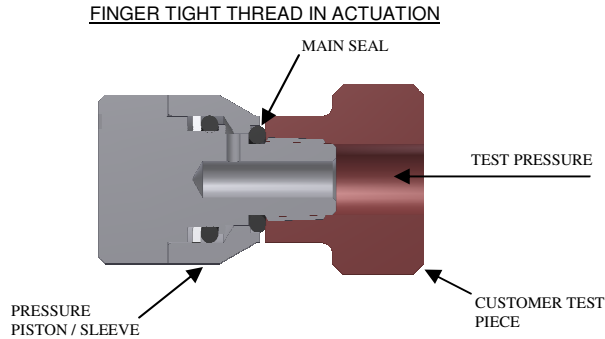

THREADED MALE CONNECTOR STYLE

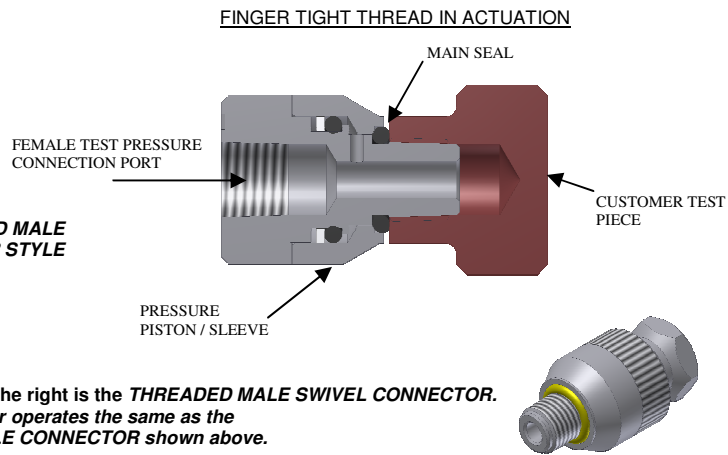

Note: Shown to the right is the **THREADED MALE SWIVEL CONNECTOR**. Swivel connector operates the same as the **THREADED MALE CONNECTOR** shown above.

Please thoroughly read the instructions prior to operating the connector. The *TwistMate* connectors are designed to provide a safe, reliable leak-tight seal and connection when properly maintained and operated.

- The connector is designed to mate with a specific application. Verify the application prior to the introduction of pressure or processing. Use only in a safe environment. Safety chains and guards are recommended for all applications.
 - Connectors are NOT designed for permanent connections and are for temporary connections only. Inadvertent loosening and loss of media may result when used as a permanent connection.
 - Connectors are not internally valved and will not prevent loss of media when disconnected.
- DO NOT EXCEED pressure rating as marked on connector or corresponding literature. Operating pressure rating based on tests using NPTF threads (to SAE J476a Dryseal specifications) of cold drawn steel. Material or thread deviations may reduce working pressure and should be verified by test.

OPERATION:

1. Fasten *TwistMate* connector securely to pressure supply line or manifold by threading connector wrench-tight using wrench flats on body or hex flats on swivel unit.
2. Thread *TwistMate* connector finger-tight onto test piece until Main Seal contacts test piece.
3. Introduce test pressure to *TwistMate*. Connector will automatically seal when internal pressure is applied.
4. Perform evacuation / filling operations.
5. To remove, release test pressure and thread off connector.

CONNECTOR MAINTENANCE:

- A daily, weekly and periodic inspection of the connector by competent person is recommended.
 - User must establish a regular interval for maintenance as determined by the user media and operational environment.
 - Inspection should include damage to the body missing or loose components, leak tightness, ease of operation, sufficient lubrication, wear, dirt accumulation and damage.
- Inspect threads for wear.
- Use only original **FastTest** spare parts that are designed for the application and are subject to strict quality control. See warranty.
- **FastTest** recommends a daily visual inspection of the main seal located in the front of the sleeve. Inspect for tears or cracks in the seal surface. Replace the main seal if tears or cracks are visible.
- Lubricate on regular intervals under normal operating conditions. Lubrication should be compatible with user application.

MIT CONNECTOR

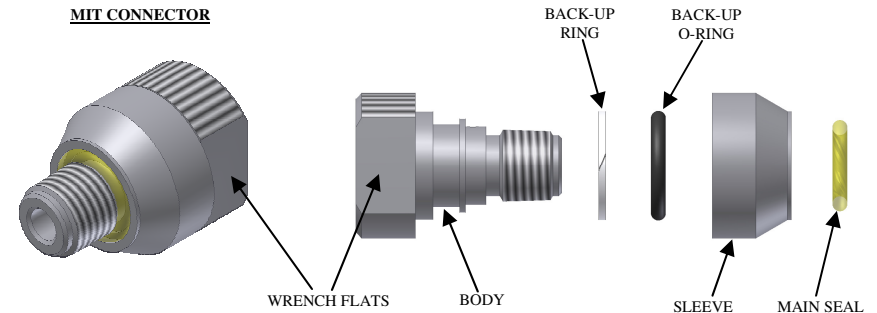

FasTest, Inc. Product Warranty

FasTest, Inc. warrants its products against defects of workmanship and/or material for 12 months from the date of the sale by FasTest, Inc. This warranty is void if the product is misused, tampered with or used in a manner that is not in accordance with FasTest, Inc. recommendations and/or instructions. FasTest, Inc. is not liable for consequential or other damages including, but not limited to, loss, damage, personal injury, or any other expense directly or indirectly arising from the use of or inability to use its products either separately or in combination with other products. ALL OTHER WARRANTIES EXPRESSED OR IMPLIED, WHETHER ORAL OR WRITTEN, INCLUDING BUT NOT LIMITED TO WARRANTIES OF MERCHANTABILITY OR FITNESS FOR A PARTICULAR PURPOSE ARE EXPRESSLY EXCLUDED.

Remedy under this warranty is limited to replacement of the product or an account credit in the amount of the original selling price, at the option of FasTest, Inc. All allegedly defective products must be returned prepaid transportation to FasTest, Inc. along with information describing the products performance, unless disposition in the field is authorized in writing by FasTest, Inc.

TwistMate

PAT# 4,688,830

www.fastestinc.com
Roseville, MN
Ph 1-800-444-2373
Fax 651-645-7390
WP096 10/7/2010

OPERATING INSTRUCTIONS

Female Connection Port Installation:

This applies to the following two styles.

Threaded Male and Swivel Male Connectors.

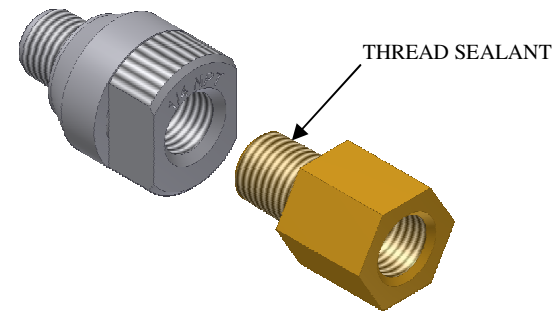
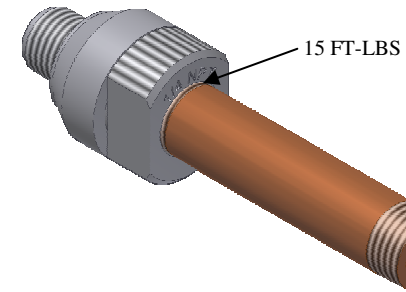
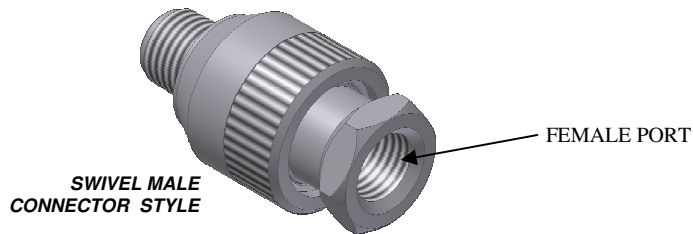
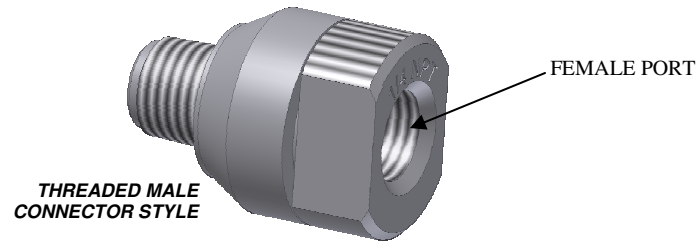

1. Whatever type of fitting you connect to our female port, you must use a 'thread sealant' and tighten to a maximum of 15 ft-lbs. See examples below and right.

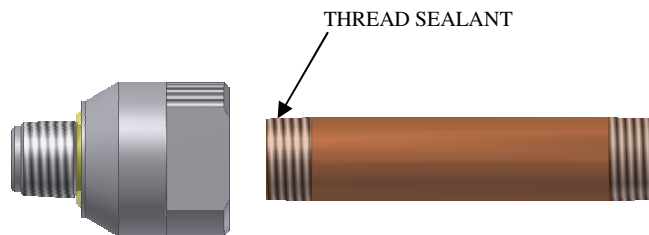

Ex. CONNECTION

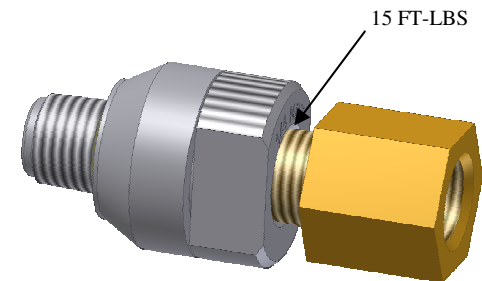

Ex. CONNECTION