



# eVmP Manual

## ELECTRONIC VARIABLE METERING PUMP

Manual Edition: 20.06  
Patent No. US 7,708,535 B2

## Table of Contents

<b>Overview</b>	<b>3</b>
<b>eVmP</b>	<b>3</b>
Features	4
<b>1.1 Safety Instructions</b>	<b>5</b>
<b>1.2 Technology</b>	<b>6</b>
1.2.1 Rotating & Reciprocating Piston Design	6
1.2.2 Electronic Volume Adjustment	7
<b>1.3 Models, Volumes &amp; Specifications</b>	<b>8</b>
<b>Getting Started</b>	<b>9</b>
<b>2.1 General Set-Up</b>	<b>9</b>
<b>2.3 Mounting</b>	<b>10</b>
2.3.1 Mounting for Best Performance	11
2.3.2 Mounting Pump Head with Isolated Glad (Washport)	11
<b>2.4 Calibration</b>	<b>12</b>
<b>2.5 Troubleshooting</b>	<b>14</b>
2.5.1 eVmP Reset	14
2.5.2 Air Bubbles	16
2.5.3 High Viscosity Fluids	16
<b>Communication</b>	<b>17</b>
<b>3.1 Specifications</b>	<b>17</b>
3.1.1 Power	17
3.1.2 Connectors	17
3.1.3 Cables	19
<b>3.2 Digital I/O</b>	<b>20</b>
<b>3.3 RS485</b>	<b>22</b>
3.3.1 Device Manger (Windows)	23
3.3.2 Command Line (Mac, Linux)	23
3.3.3 RS485 Commands	24
<b>3.4 EtherNet/IP</b>	<b>29</b>
3.4.1 Connecting to EtherNet/IP	29
3.4.2 EtherNet/IP Commands	30
<b>Operation</b>	<b>35</b>
<b>4.1 TSi Layout</b>	<b>35</b>
4.1.1 TSi Information Screen	35
4.1.2 TSi Main Menu (Page 1)	36
4.1.3 TSi Main Menu (Page 2)	37
4.1.4 TSi Program Linking Menu	38
4.1.5 TSi Settings Menu	39
4.1.6 TSi Checklist	40
<b>4.2 Functions</b>	<b>41</b>

4.2.1 TSi Main Navigation	41
4.2.2 TSi Main Menu (Page 1)	41
4.2.3 TSi Program Linking Menu	44
4.2.4 TSi Main Menu (Page 2)	45
4.2.5 TSi Settings Menu	46
4.2.6 TSi Checklist Menu	46
<b>Maintenance</b>	<b>49</b>
5.1 Consumables	49
5.2 Cleaning	50
5.2.1 M-Series	50
5.2.2 V-SAN	56
5.2.3 VS6-Series	60
<b>Specifications</b>	<b>64</b>
6.1 M-Series	64
6.1.1 M-Series Specifications	64
6.1.2 M-Series Pump Drives	65
6.1.3 M-Series Pump Heads	65
6.2 V-Series	67
6.2.1 V-Series Specifications	67
6.2.2 V-Series Pump Drives	68
6.2.3 V-Series Pump Heads	69
6.3 VS-Series	70
6.3.1 VS-Series Specifications	70
6.3.2 VS-Series Pump Drives	71
6.3.3 VS-Series Pump Heads	71
6.4 VS6-Series	71
6.4.1 VS6-Series Specifications	71
6.4.2 VS6-Series Pump Drives	73
6.4.3 VS6-Series Pump Heads	74
6.5 eVMP Dual Enclosure	75
6.5.1 Dual Enclosure Specifications	75
6.5.2 Dual Enclosure	76
6.5.3 Dual Enclosure Compatible Pump Drives	77
6.6 TSi	77
<b>One Year Limited Warranty</b>	<b>78</b>
Terms and Conditions	78
<b>Technical Support</b>	<b>79</b>

# Overview

## eVmP SMART PUMP

Patent No. US 7,708,535 B2



**Visit: <https://www.zaxisinc.com/service/evmp-set-up/> for a video overview.**

The Patented eVmP system is a precision metering and fluid dispenser combined with a Touch Screen Interface (TSi) for simple programming and immediate teach and control. This pump technology combines precision ceramic pump components and an electronically controlled linear stepper actuator to make ultra-fine adjustments to pump angle position, thereby changing the volume of metered liquid. This allows the eVmP system to provide dynamic fluid displacement to overcome variations in viscosity and surface tension. One of the many attributes of this pump is that it has no valves and has only one moving part, the ceramic piston. This will provide millions of maintenance free cycles (approximately 84,000,000).

This unit contains an embedded micro-controller and will communicate directly to a host device (Computer or PLC) via a serial port, or Ethernet connection. No other controls are needed. The eVmP Touchscreen Interface will control up to 32 pumps. All parameters, such as volume, speed, number of cycles, are all programmed from the TSi. The host can be disconnected, and the pump will continue its current program.

The pump head used in the eVmP system is a rotating and reciprocating ceramic piston design. The ceramic piston and the liner are precision matched sets and the assembly is manufactured to extremely tight tolerances, ensuring the best accuracy and repeatability. This pump design eliminates the need for external supply and discharge valves. The intake port of the pump is never connected to the discharge port. The eVmP is the latest in fluid metering and dispense technology.

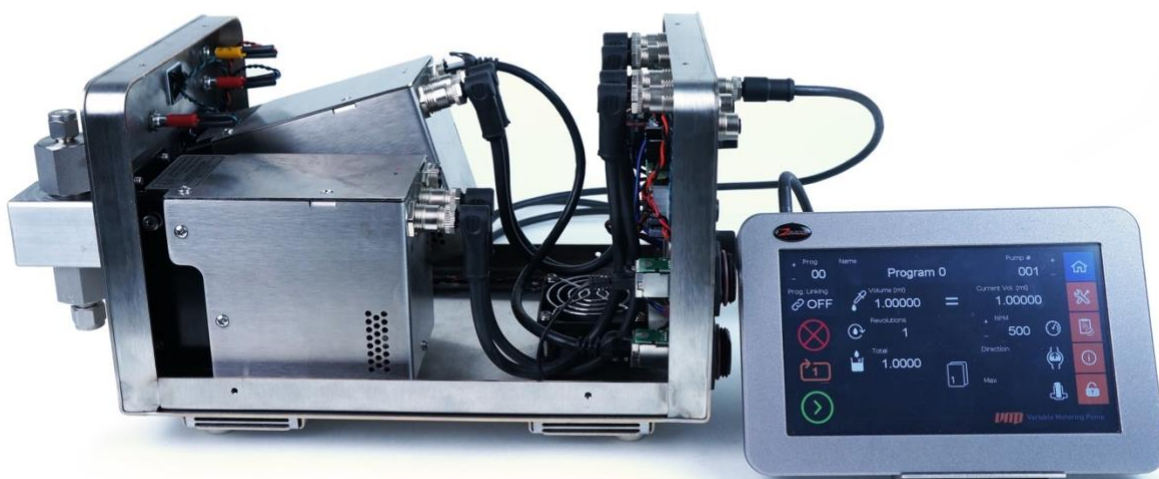

## Features



Ceramic, Teflon, or  
Fluid Path



Valveless Design



0.01 $\mu$ L Resolution



Programmable Stroke  
Adjustment



Embedded  
Micro-Controller



50 Stored Programs



EtherNet/IP, RS485,  
Digital I/O  
Communication



Intuitive Color  
Touchscreen Interface

- Valveless operation with ceramic Piston and Liner
- One moving part in contact with fluid
- Embedded Micro-controller and dual amplifier
- Variable Displacement
- Low Dead Volume
- Low liquid shear
- Self-priming
- Flow Direction Reverse
- Panel Mounting Provisions
- Durability
- Chemically inert
- Autoclaveable

# 1.1 Safety Instructions

## PLEASE READ BEFORE OPERATING PUMP AND CONTROLLER

**Caution:** Before using any equipment read the following safety instructions as well as specific product specifications and operating instructions.

**Warning!** Fire, electrical shock or explosion may occur if used near combustibles, explosive atmosphere, corrosive air, wet environment or submerged in fluid.

**Caution!** Fire, electrical shock, injury and damage may occur if not used in accordance with eVmP specifications and operating instructions.

- Turn off electrical power before checking pump for any problems.
- We recommend pumps are mounted using approved mounting methods. See section 2.3
- Connect motor, controller or any other electrical devices based on eVmP specifications. Any unauthorized work performed on the product by the purchaser or by third parties can impair product functionality and thereby relieve eVmP of all warranty claims or liability for any misuse that will cause damage to product and/or injury to the individual.
- Power cables and leads should not be bent, pulled or inserted by excessive force. Otherwise there is a threat of electrical shock or fire.
- Do not touch any rotating pump or motor components, injury may occur.
- Replace any inline fuses only with fuse rating as specified by Zaxis for the eVmP
- When pump/drive is under operation, never point discharge tubing into face or touch any rotating components of pump. In a power down thermal overload cut-in condition, unplug or turn off power to pump. Always allow a cool down period before restarting, otherwise injury or damage may occur.
- **Do not run pump dry**, unless designed for that service. Running dry is harmful to the pump and will cause excessive heating due to internal friction.
- For 30 seconds after power is removed from pump/drive: do not touch any output terminals. Electrical shock may occur because of residual voltage.
- Check pump rotation and inlet/outlet pump port orientation before connecting power to pump. If not, injury may occur.
- Do not operate with wet hands.
- When pulling cords from outlets do not pull cord, grasp plug to prevent plug damage or electrical shock.
- eVmP drive motors become HOT and can cause a burn. DO NOT TOUCH!

# 1.2 Technology

## 1.2.1 Rotating & Reciprocating Piston Design

The valveless pumping function is accomplished by the synchronous rotation and reciprocation of the ceramic piston in a precisely mated ceramic cylinder liner. One complete piston revolution is required for each suction and discharge cycle, shown below in Figure 1.

**Figure 1**

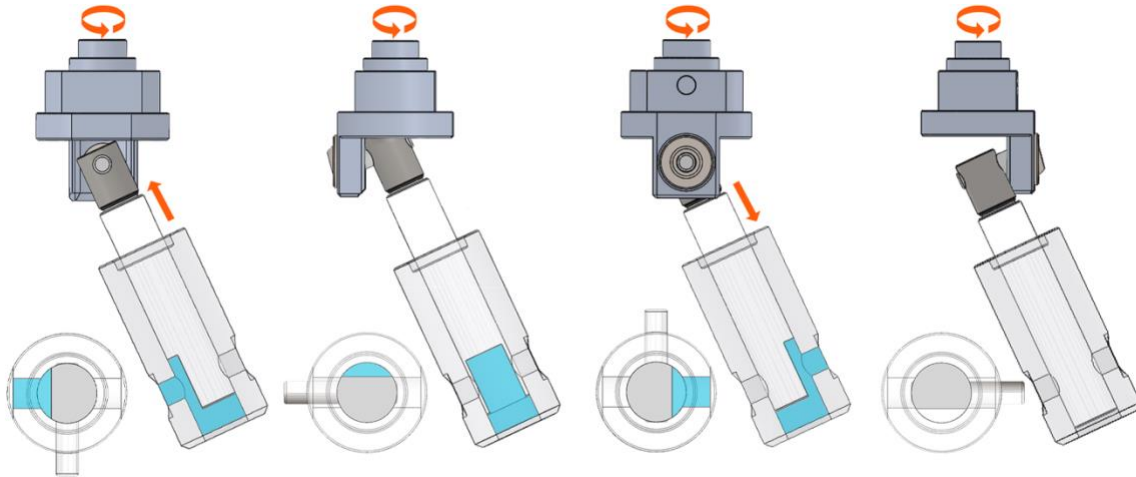

### SUCTION

The piston rotates and reciprocates. As the piston is pulled out of the liner and the piston flat opens to the inlet port, suction is created, and fluid fills the pump chamber.

### CROSSOVER

As the piston rotates the inlet port is sealed with the pump chamber full. As the piston continues to rotate, the outlet port opens up. **Only one port is open at any time and at no time are both ports interconnected.**

### DISCHARGE

Reciprocation continues as the piston front flat opens to the outlet port, forcing the piston back into the liner, expelling all of the fluid contained in the pump chamber.

### CROSSOVER

Piston rotation continues sealing off the outlet port leaving the pump chamber empty until the flat of the rotating piston opens to the inlet port again.

## 1.2.2 Electronic Volume Adjustment

The patented eVmP Smart Pump system is a precision metering and fluid dispenser combined with a detachable Touch Screen Interface (TSi) for simple programming and immediate teach and control. This pump technology combines precision ceramic pump components and an electronically controlled linear stepper actuator to make ultra-fine adjustments to angle position, thereby changing the volume of metered liquid. This allows the eVmP system to provide dynamic fluid displacement to overcome variations in viscosity and surface tension. The eVmP is the latest in fluid metering and dispense technology.

**Figure 2**

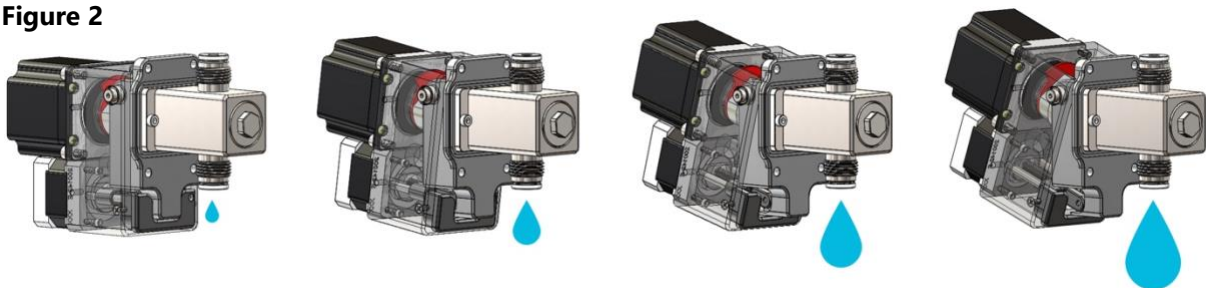

A Linear actuator changes the angle of the pump head relative to the drive, which can be seen above in Figure 2. This angle changes the stroke length of the piston thereby changing the dispense volume. The greater the angle the more volume can be dispensed. The smaller the angle the lower the volume.

**Patent No.** US 7,708,535 B2



## 1.3 Models, Volumes & Specifications

SERIES	MATERIAL OPTIONS	MAX RPM	MAX PSIG	HEAD	PISTON SIZE	MAX ML/REV	MAX ML/MIN
<b>M</b>	CKC	1000	100	M0	3/16"	0.05	50
				M1	1/4"	0.10	100
<b>V</b>	SAN/CKC	1000	100	V1	1/4"	0.32	320
				V2	3/8"	0.72	720
				V3	1/2"	1.28	1280
<b>VS</b>	SAN/CKC	1500	200	V1	1/4"	0.32	450
				V2	3/8"	0.72	1080
				V3	1/2"	1.28	1920
<b>VS6</b>	SAN	1500	25	VS6	1"	6.00	9000

\* Speed Dependent on Viscosity

§ Micro (M) Pumps Dispense As Low As 0.5 µL



### M-SERIES

Metering and Dosing Microliters



### V-SERIES

Stepper-driven Precision Dosing and Automated Metering



### VS-SERIES

Servo Precision Metering Pumps



### VS6-SERIES

Extra Large Flow Capacity

# Getting Started

IN THIS SECTION WE WILL GO OVER WHAT COMES WITH YOUR PUMP AND HOW TO SET IT UP.

## 2.1 General Set-Up

**UNPACK AND INSPECT ALL COMPONENTS TO MAKE SURE THEY ARE ALL PRESENT AND NO DAMAGE OCCURRED DURING SHIPPING**

Connect the VMP to the Power Supply Kit or other appropriate power source (24VDC) through the 12 Pin I/O Cable. Connect the 8 Pin RS485 cable from the TSi to the RS485 receptacle.

### M-SERIES, V-SERIES, VS-SERIES, VS6-SERIES

1. Powered I/O
2. RS485 for TSi
3. EtherNet/IP
4. Hard Reset Button

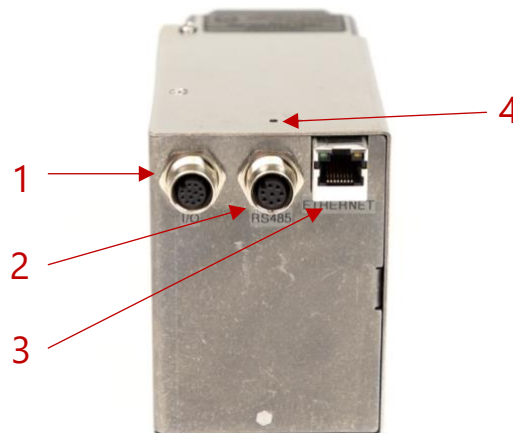

### eVmp DUAL ENCLOSURE

1. RS485 for TSi
2. Digital I/O
3. EtherNet/IP
4. 2nd RS485 used to daisy chain Dual Enclosures
5. On/Off Switch
6. 2 Fuses (5x20mm fast-acting glass body cartridge fuse. Rating: 250V/2A.)
7. 4 Pin Power Connection



## 2.3 Mounting

### PUMP DAMAGE WILL OCCUR IF THE PUMP IS MOUNTED INCORRECTLY.

M-Series pump heads have a horizontal orientation in relation to their drive where V-Series and VS-Series pump heads have a vertical orientation in relation to their drive. Once the pump head is mounted, the tubing can be connected. The **Inlet (Suction)** side of the pump operates best when orientated downwards while using tubing with the largest inside diameter that your application will allow. This minimizes the chance for cavitation. **For the Outlet (Discharge) side of the pump, tubing should have an inside diameter equal to or smaller than that of the inlet tubing.**

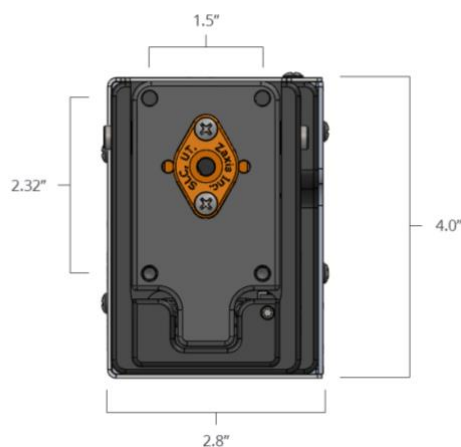

#### M-SERIES

Correct Mounting Orientation



#### M-SERIES

Incorrect Mounting Orientation

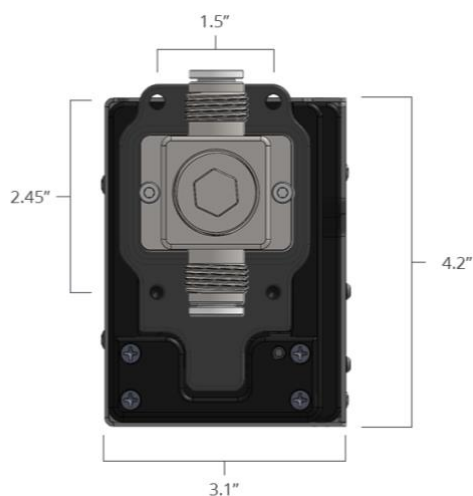

#### V-SERIES & VS-SERIES

Correct Mounting Orientation

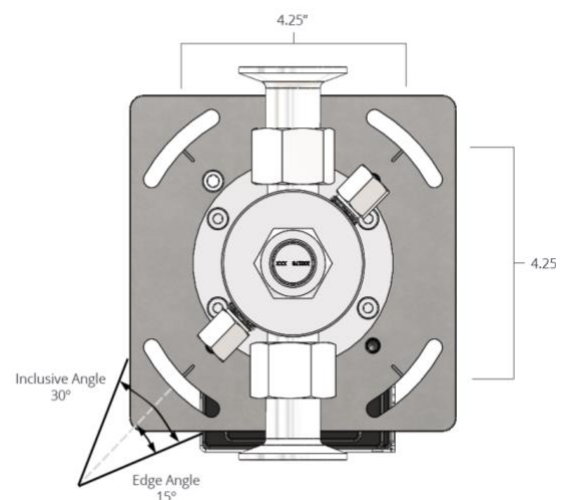

#### VS6-SERIES

Correct Mounting Orientation

Mountain Plate P/N: 300284

### 2.3.1 Mounting for Best Performance

**Figure 3**

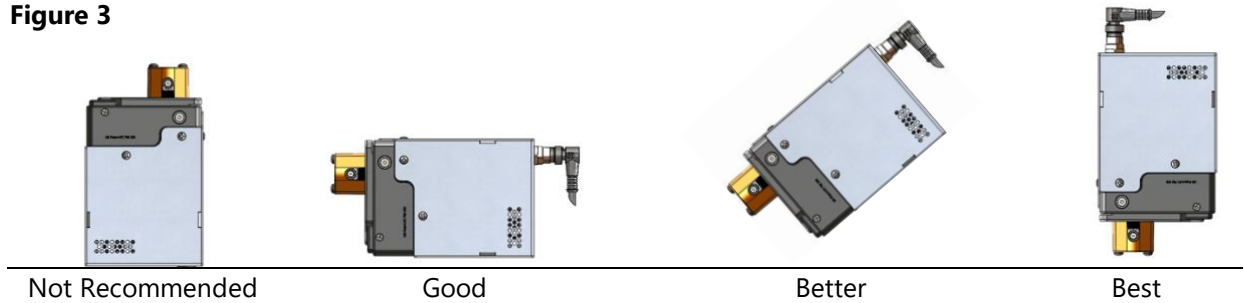
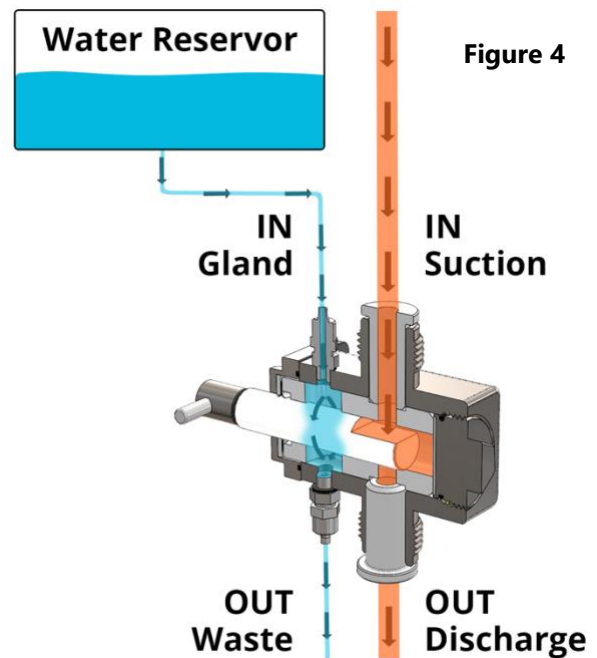

Figure 3 displays pump mounting orientation. For maximum performance mount the pump drive vertically with pump head facing down. The discharge tubing should be directed upwards in relation to the pump head. This vertical setup allows air bubbles that enter the pump chamber to exit more easily using buoyancy.

### 2.3.2 Mounting Pump Head with Isolated Gland (Washport)

The VS6SAN-W and the V-SAN-W pump head, which is available for the V-Series and VS-Series eVmP pumps, both have an isolation gland or “washport”. As seen in figure 4, this extra port creates a barrier of liquid that isolates the fluid being pumped from the pump head seals and atmosphere.

The V-SAN-W pump head Isolated Gland ports works with most 0.25” O.D. (0.17” I.D) tubing. The VS6SAN-W isolated glad ports are compatible with 1/8” NPT fittings. A second pump can be used to cycle isolation fluid through the gland, or a reservoir can be positioned above the Isolated Gland and gravity will feed the isolation fluid through the gland.



## 2.4 Calibration

### Tools, Gages, Fixtures

- 3/32" L-Hex Wrench

### Safety Requirement

- Always wear safety glasses.

### STEP 1

To begin the manual calibration process, set the pump volume to "0".



### STEP 2

Then insert a 3/32" L-Hex Wrench into the open hole on the bottom right of the front of the pump and find the "zero" set screw.

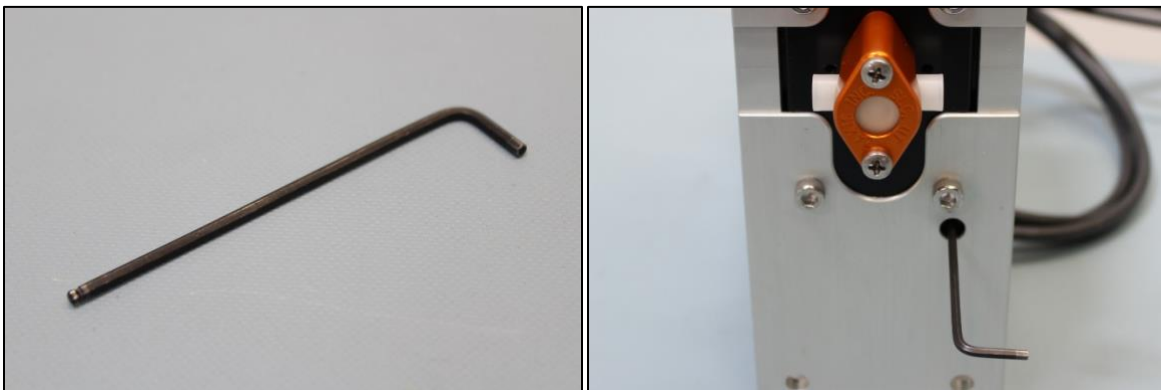

### STEP 3

Once the L-Hex Wrench is engaged with the "zero" set screw turn the wrench clockwise to increase the volume or counter-clockwise to decrease the volume. Start with small adjustments such as 1/8th turns and gradually adjust the pump to avoid moving the calibration too much.

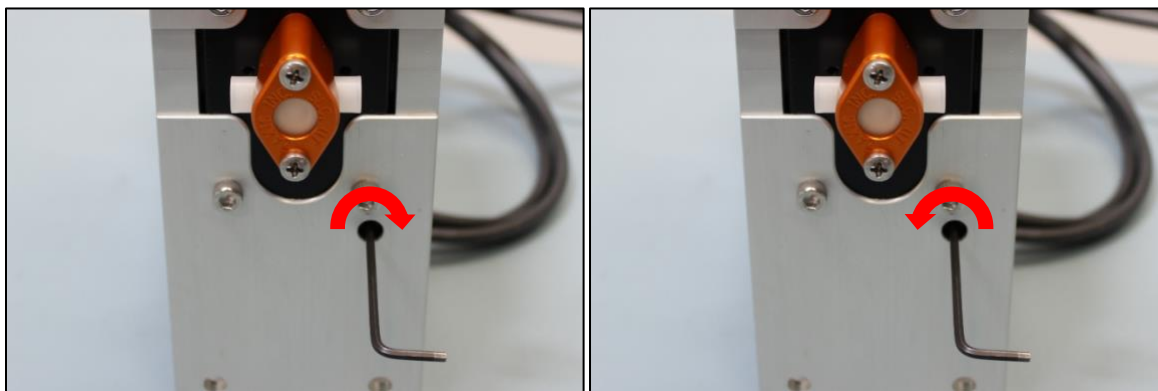

Increase Volume

Decrease Volume

### STEP 4

After the "zero" set screw has been adjusted press the "=" or "Set" button on the TSi to complete the adjustment. Then use a pan balance scale to verify the volume change is correct.



### STEP 5

If the volume still needs to be adjusted, repeat steps 3.0 and 4.0 until the desired volume is reached.

## 2.5 Troubleshooting

### 2.5.1 eVmP Reset

If the eVmP is experiencing communication issues the first trouble shooting procedure is to reset the eVmP.

The eVmP has two levels of resets, soft and hard, both levels will not affect the calibration, so it is safe to perform without the need to re-validate the pump performance.

#### Performing a Soft Reset

A soft reset will set the pump to pump number 1 and should restore communications in most cases. The soft reset will not erase any settings on the pump.

1. Begin with the pump powered on. Then find the small circular hole next to the red LED on the back of the pump, next to the ethernet, I/O and RS485 connections.

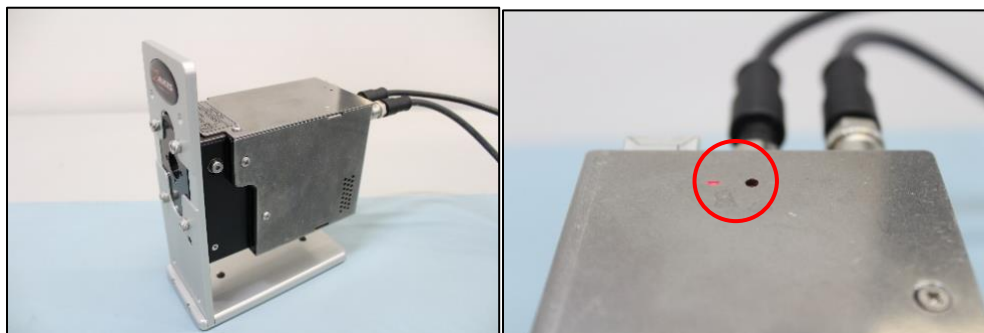

2. Take a stylus or pen and press and release the small button inside the circular hole.

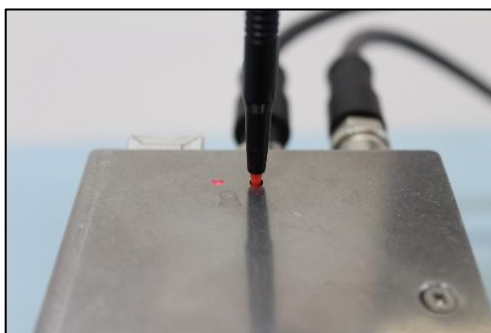

3. The red LED will flash once indicating that the soft reset procedure has been performed. If the pump is still having communication issues move onto the next step which is the hard reset.

## Performing a Hard Reset

**A hard reset will reset the pump to its factory settings, meaning it will erase all the data on the pump.** This includes any stored programs or recipes, pump numbers and ethernet settings. This will not erase the serial number, calibration settings, or bore size of the pump.

1. Start with the pump powered down. Then press and hold the small button in the circular hole. While continuing to hold the small button power the pump on. Continue to hold the button until the red LED flashes then release the button.

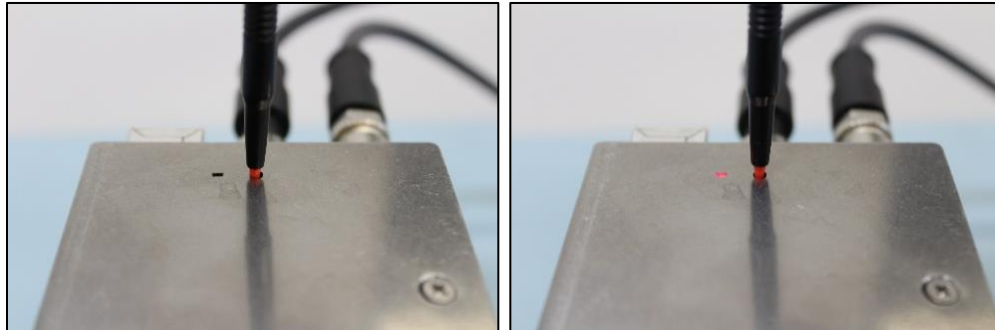

2. Once the LED flashes the pump has performed a hard reset. All the information entered by the user will be erased but the calibration will not be affected.
3. If your communication issue persists through the two reset procedures, please call Zaxis for further troubleshooting help at 1-801-264-1000.



## 2.5.2 Air Bubbles

Loud Noise At high rpm rates you may hear a loud hammering sound. This can be caused from bubbles being present in the pumping chamber. Causes and solutions for bubbles in the pumping chamber might include:

1. Poor seal at the suction fitting Solution:
  - a. Use Teflon tape to seal the inlet fitting
2. Fluid vaporization or cavitation and degassing Solutions:
  - a. Increase the diameter of the suction tubing
  - b. Reduce suction lift height.
  - c. Pressurize suction supply container
  - d. Position pump below the supply source for gravimetric flow
  - e. Reduce viscosity of fluid by heating or diluting
  - f. Reduce flow rate
  - g. Add pulse suppressors in suction and discharge lines (This can also be accomplished by adding resilience in your fluid circuit)
  - h. Resilient tubing can act as a pulse suppressant, which might include flexible tubing such as viton, hypalon, gum rubber, or soft vinyl
  - i. Shield this tubing in case of rupture.
  - j. Bubble traps can also be used as pulse suppressants.

## 2.5.3 High Viscosity Fluids

One or more of the following measures may be helpful for viscous fluids above 500cP:

1. Lower the RPM; fluids with a high viscosity do not flow well when subjected to high pressure created by high RPMs
2. The inlet suction tubing should be large as possible
3. The discharge line should be as large as possible without being larger than the inlet line
4. Consider reducing the viscosity either by diluting or heating the fluid. Be sure to check the operational temperature of your pump head
5. Position the pump below the supply source for gravimetric flow

### Note

The molecular chemical composition of certain fluids may pose a pumping challenge even though a similar viscous fluid can be easily pumped. Typically, polymers in the Cationic family may pose such difficulties.

# Communication

MULTIPLE COMMUNICATION OPTIONS ARE AVAILABLE AS STANDARD, INCLUDING DIGITAL/IO, RS485 AND ETHERNET/IP.

## 3.1 Specifications

### 3.1.1 Power

Pump Drive	System Power
M-Series	24 VDC 2 Amps
V-Series	24/36 VDC 2 Amps
VS-Series	24/36 VDC 2 Amps
VS6-Series	24/36 VDC 4 Amps (75 VDC 5 Amp Power Optional)
Dual Enclosure	120/240 VAC 50/60 Hz

### 3.1.2 Connectors

Connectors on eVMP Smart Pump Drives are M12-A Series 763 8-Pin or 12-Pin female connectors with female pins.

#### Specifications:

- Shielding: Shielded
- Contacts: 8 and 12
- Contact Plating: Gold
- Ingress Protection: IP 68
- Locking System: M12-A
- Maximum Diameter: 14.5 mm
- Rated Voltage for 8 Pin: 60 V
- Rated Voltage for 12 Pin: 30 V
- Rated Current for 8 Pin: 2 A
- Rated Current for 12 Pin: 1 A

### TSi Com Strip

In order to run multiple eVMP Smart Pumps with one TSi (Touch Screen Interface) a com strip is required. Simply connect the Grey, Pink, Green, and Yellow wires from the first pump as well as the Green and Yellow wires of each additional pump to a com strip. The TSi can operate up to 32 pumps.

Figure 5

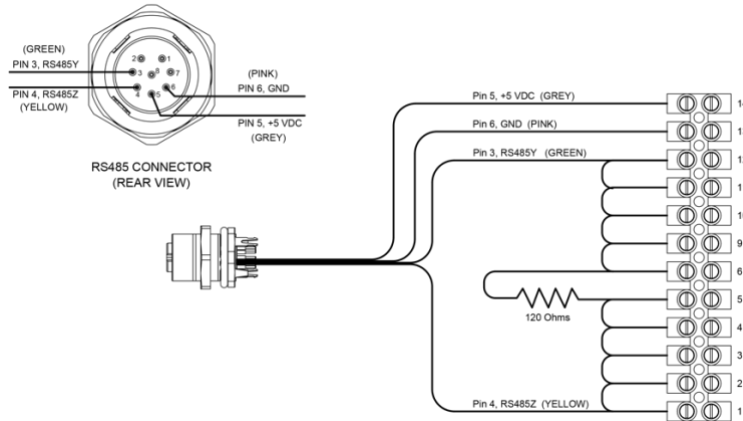

### Dual Enclosure I/O Switches

I/O switches are internal components (see figure 6 below) and should be configured to client specifications by the manufacturer. Contact [support@zaxisinc.com](mailto:support@zaxisinc.com) for questions.

	SW 1	SW 2	SW3
Jumper Up	No GND(Ground) to screen.	External Power must be supplied to I/O to use I/O.	Pumps A and B start on their individual start inputs.
Jumper Down	Required to power screen (TSi).	Internal Power is supplied for I/O but signals can't go through M12 connector.	Pump A and B both start on either of the pump start inputs.

Figure 6

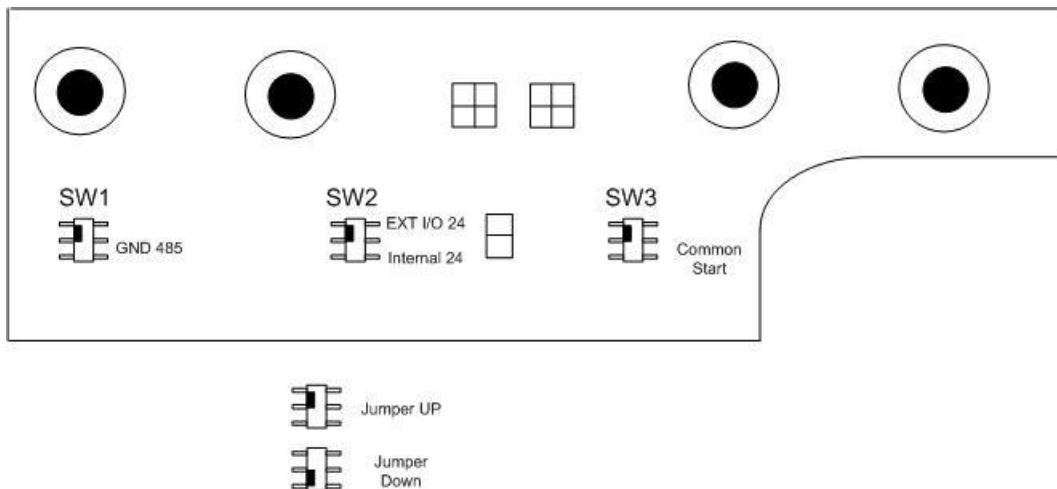

### 3.1.3 Cables

Series 763, single ended, 2m PUR cable. Available in 8 pin and 12 pin with either straight and 90° angle with male connector and male pins.

#### Specifications:

- Termination: Overmolded
- Shielding: Non-shielded
- Contacts: 8 or 12
- Contact Plating: Gold
- Ingress Protection: IP 69K
- Locking System: M12-A
- Shell Material: Plastic
- Maximum Diameter: 14.5 mm
- Cable Length: 2 M
- Rated Voltage for 8 Pin: 60 V
- Rated Voltage for 12 Pin: 30 V
- Rated Current for 8 Pin: 2 A
- Rated Current for 12 Pin: 1 A

<b>Cable Description</b>	<b>Part Number</b>
12 Pin – Right Angle – 2 Meter	100273
12 Pin – Right Angle – 5 Meter	100277
12 Pin – Straight – 2 Meter	100091
12 Pin – Straight – 5 Meter	100267
8 Pin – Right Angle – 2 Meter	100090
8 Pin – Right Angle – 5 Meter	100279
8 Pin – Straight – 2 Meter	100089
8 Pin – Straight – 5 Meter	100392

## 3.2 Digital I/O

### START eVMP SMART PUMP WITH DIGITAL I/O

In order to communicate via the discrete I/O the Smart Pump needs to have power along with the I/O. In the diagram below it shows that I/O + (brown) should be connected to +24VDC and I/O - (blue) should be connected to GND.

**Normal Mode:** In normal mode the Smart Pump will dispense when on the falling edge of the "Start In" (pink) signal.

**Continuous Mode:** If the Smart Pump mode is in continuous mode it will dispense the entire time "Start In" (pink) is held high.

**Ready Input:** If the Ready Input is enabled the "Ready In" (yellow) signal must be driven high, at least 14 volts or higher of the available 24 volts, in order to operate the pump.

**Count Out:** The Count Out (green) cable will give a high output signal after every piston revolution to digitally track dispensing.

Pin No.	12 Pin Cable	
	Label	Mating Cable
1	I/O +	Brown ↯
2	I/O -	Blue ↯
3	Busy Out	White
4	Count Out	Green
5	Start In	Pink
6	Ready In	Yellow
7	GND	Black *
8	GND	Grey *
9	+24 VDC	Red **
10	+24 VDC	Purple **
11	N/A	Grey/Pink
12	N/A	Red/Blue

*Matching special characters indicate cables that are tied together.*

**12 Pin Cable (eVMP Dual Enclosure)**

Pin No.	Label	Mating Cable
1	I/O +	Brown ↯
2	I/O -	Blue ↯
3	Busy Out A (out)	White
4	Count Out A (out)	Green
5	Start A (in)	Pink
6	Ready A (in)	Yellow
7	Busy B (out)	Black *
8	Count B (out)	Grey *
9	Start B (in)	Red **
10	Ready B (in)	Purple **
11	N/A	Grey/Pink
12	N/A	Red/Blue

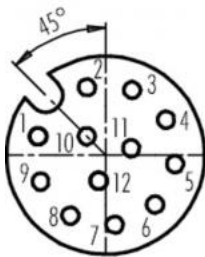

## 3.3 RS485

### SIMPLE LEGACY SYSTEM TO SYSTEM COMMUNICATION WITH LONG SUPPORTED DISTANCE

For simple communication with the eVMP Smart Pump via RS485 use a USB to RS485 adapter for easy connectivity to the 8 Pin M12-A Series 763port on the back of the Smart Pump.

<b>8 Pin</b>		
Pin No.	Label	Mating Cable
1	N/A	White
2	N/A	Brown
3	RS485Y (1/2 Duplex)	Green
4	RS485Z (1/2 Duplex)	Yellow
5	+5 VDC TSi power	Grey
6	GND	Pink
7	N/A	Blue
8	N/A	Red

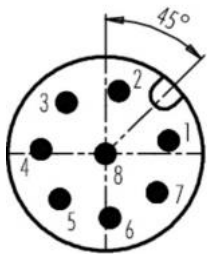

### 3.3.1 Device Manger (Windows)

No matter which version of Windows you have, you have a program called Device Manager. To open device manger, open the start menu, and look for the COM port that is linked to your eVMP Smart Pump. If you do have multiple devices and are not sure which device is the one you just plugged in, unplug it, watch for whichever COM port disappears, and then plug it back in. The COM port should reappear letting you know that's the device you're looking for.



### 3.3.2 Command Line (Mac, Linux)

Similar to Windows, Mac OS and Linux both assign a specific port to every device attached to the computer. However, unlike Windows, there is no specific program you can open up to view all the devices currently attached.

The default command line interface for Mac OS X is Terminal. To open it, go to your Utilities folder. There you should see the icon for Terminal.

To see a list of all the available Serial ports on both Mac and Linux, type the following command:

```
ls /dev/tty.*
```



To communicate with the pump you can use a serial terminal program such as RealTerm. The image below has the default settings for communicating over rs485(half duplex).

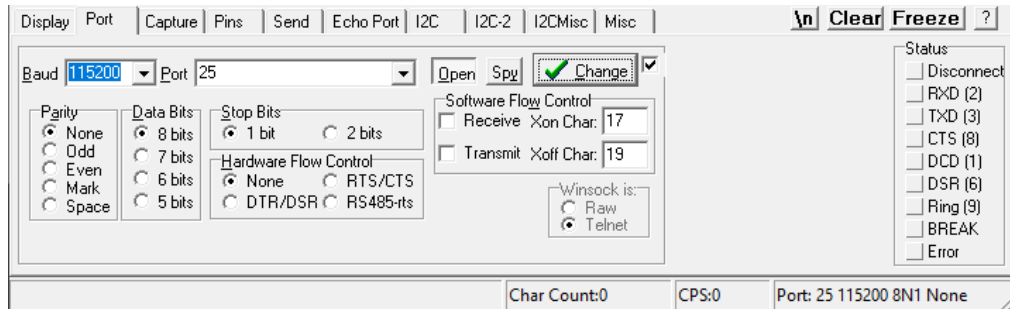

- ie. <001SRP> will run the dispense motor on pump number 1
- ie. <000SCS> will set the current shot volume for all pumps connected

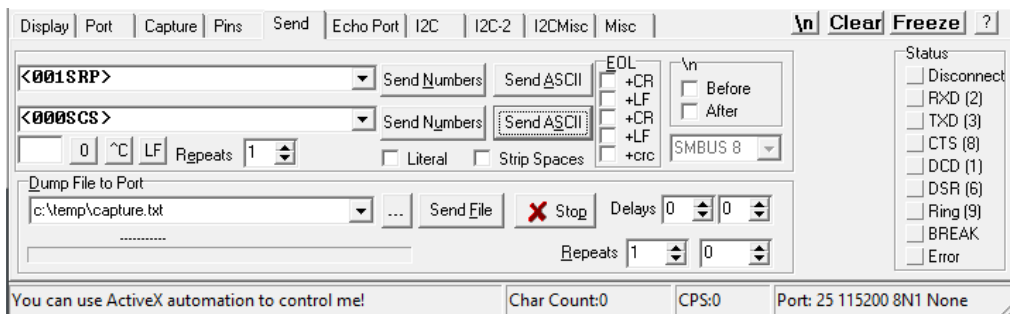

### 3.3.3 RS485 Commands

The syntax for communicating over rs485 is "<" + Pump Number 001 (000 to send command to all pumps)+command+">" .

TSI BUTTON	SHORT DESCRIPTION	INPUT STRING	QUERY RETURN STRING	COMMENTS	RANGE OR LIMITS	STOREDPARAMS OR STOREDPUMPPARAMS OR CALDATA
		0 1 2			If motor enable any set command is ignored	
<b>RED BUTTON WITH X IN IT</b>	Abort	~ ~ ~	N/A	Aborts currently running program	Only the first ~ is required.	Abort set to 1
	Adjust Acceleration	S A A	QAA%02d	Adjust Acceleration	Between Min_Accel and Max_Accel	adjust_accel
	Adjust Deceleration	S A D	QAD%02d	Adjust Deceleration	Between Min_Accel and Max_Accel	adjust_decel
	Adjust Initial Speed	S A I	QAI%04d	Adjust Initial Speed	Between MinInitialSpeed and MaxInitialSpeed	adjust_initial_spd

	Adjust Speed	S	A	S	QAS%04d	Adjust Speed	Between MinAdjustSpeed and MaxAdjustSpeed 0 to 100	adjust_spd
	Adjust A/D Voltage	S	A	V	QAV%03d	Adjust A/D converter voltage		adjust_dac
	Set Baud Rate	S	B	R	QBR%ld	Sets baud rate for serial communications. Baud rate must be set to 115200 if using TSi	96, 192, 384, 576, 1152 Trailing zeros are ignored	baud
	Discernmentfine adjust	S	C	D	QCD%3d	Moves the adjust motor down 1 or more steps, decreasing the shot size.	20 to -20	fineAdjust
	Increment fine adjust	S	C	I	QCI%3d	Moves the adjust motor up 1 more steps, increasing the shot size.	20 to -20	fineAdjust
<b>CLEAR FLAG FAULT</b>	Clear motor fault flag	S	C	F		Pump and adjust motor fault flag clear		
<b>PRE-PUMP CLAMP</b>	Set pre pump clamp time	S	C	G	QCG%d	Pre pump clamp ms		preBusyDelay
<b>POST PUMP CLAMP</b>	Set post pump clamp time	S	C	H	QCH%d	Post pump clamp ms		postBusyDelay
<b>PROG</b>	Set current program number	S	C	P	QCP%02d	Change to indicated program number	0 to 49	curr_prog
<b>EQUAL/NOT EQUAL SIGN BUTTON</b>	Set current program shot	S	C	S	N/A	Pump adjusts volume to current program setting. Same as SCZ command.	Between offset_count and MaxShot	curr_adj_steps
<b>TOTAL</b>	Query current Volume	Q	C	V	QCV%7.5f	Query only value		setpoint
<b>FINE ADJUST ZERO OUT</b>	Clear Find Adjust	S	C	Z	N/A	Clear fine adjust and goes to home position. Same as the SCS command.		prog_adj_steps
<b>DIRECTION</b>	Set rotation direction clockwise	S	D	C	QDC	Set pump rotation direction clockwise. (Arrow points up)		dir
<b>DHCP</b>	Toggle DHCP	S	D	H	QDH0 or QDH1	If DHCP is on it is turned off, if off it is turned on	default is off. 0 = off, 1 = on	toggleDHCP()
	Calculate dispense time	S	D	T	QDT%ld			dispensetime
<b>DIRECTION</b>	Set rotation direction counterclockwise	S	D	W	QDW	Set pump rotation direction counterclockwise. (Arrow points down)		dir
<b>INFO SCREEN</b>	Query Firmware revision	Q	F	R	QFR%5.3f	QFR - returns firmware revision number		
<b>GATEWAY</b>	Set I/P gateway	S	I	G	QIG%s	DHCP is turned off before setting the gateway	default 192.168.1.1	IpGateway

<b>MAC ADDRESS</b>	Query Ethernet MAC address	Q	I	M	QIM<mac>	MAC address. QIMxx:xx:xx:xx:xx:xx	MAC Address
<b>NETMASK</b>	Set I/P network mask	S	I	N	QIN% <i>s</i>	DHCP is turned off before setting the mask	default 255.255.255.255 IpNetmask
<b>IP ADDRESS</b>	Set I/P address	S	I	P	QIP% <i>s</i>	DHCP is turned off before setting the address	default 192.168.1.130 IpAddr
	Reset Parameters	S	I	R	N/A	Resets pump to default parameters	
<b>LOOP CYCLES</b>	Loop Cycles	S	L	C	QLC%06 <i>l</i>	Number of times to execute program loop	1 to 999999 loopcycles
<b>LINK TIME DELAY</b>	Loop Delay	S	L	D	QLD%05 <i>d</i>	Delay, in seconds, before executing next program loop	0 to 32767 delay
	Set Fault	S	L	F	QLF% <i>c</i>	Set dispense fault 1=Fault, 0=No fault	
<b>HOLD ON FAULT</b>	Set Hold on Fault	S	L	H	QLH% <i>c</i>	Set hold on fault 0=No, 1=Yes	
<b>PROG. LINKING / LINKED PROGRAM SET PUMP NUMBER</b>	Next in loop	S	L	N	QLN%02 <i>d</i>	Next program to execute at end of current program (-1 to disable)	-1 to MaxProgs nextprog
	Learn Pump number	S	L	P	QLP%03 <i>d</i>	Used in multi-pump applications. Send this command, and then close the external start (foot switch) contact of the pump to save the new number.	MinPumpNumber to MaxPumpNumber setPumpNum() pumpnum
<b>MAX</b>	Set maximum dispense shot	S	M	S	N/A	Pump adjusts volume to a maximum setting.	MaxShot
<b>NAME</b>	Change current program name	S	N	P	QNP% <i>s</i>	Names the current program	1 to 15 ASCII printable characters excluding ProgName
<b>GAIN</b>	Set Gain	S	P	A	QPA%6.5 <i>f</i>	Current gain value	gain
<b>BORE</b>	Bore size	S	P	B	QPB%6.4 <i>f</i>	Pump Bore	0 to 3.402823 × 10 to 38th power bore
<b>CALIBRATION FACTORS</b>	Calibration variable 0	S	P	C	QPC%6.4 <i>f</i>	Set calibration variable.	sphericalbearing
	Calibration variable 1	S	P	F	QPF%6.4 <i>f</i>	E.g. the distance in inches from the hinge to the spherical bearing	sphericalbearing
	Calibration variable 2	S	P	G	QPG%6.4 <i>f</i>		sphericalbearing
	Calibration variable 3	S	P	H	QPH%6.4 <i>f</i>		sphericalbearing
	Calibration variable 4	S	P	J	QPJ%6.4 <i>f</i>		sphericalbearing
	Calibration variable 5	S	P	K	QPK%6.4 <i>f</i>		sphericalbearing
	Calibration variable 6	S	P	L	QPL%6.4 <i>f</i>		sphericalbearing
	Calibration variable 7	S	P	M	QPM%6.4 <i>f</i>		sphericalbearing

	Calibration variable 8	S	P	P	QPP%6.4f			sphericalbearing
<b>ZERO</b>	Zero Offset	S	P	Q	QPQ%d	Cal zero offset		zeroOffset
<b>PROG -</b>	Decrement Current Program	S	P	D	N/A	When program is 0 it becomes 49.	0 to 49	curr_prog
	Pump Errors over EherNet	S	P	E	QPE%d		0 or 1	PumpErrors
<b>PROG +</b>	Increment Current Program	S	P	I	N/A	When program is 49 it becomes 0	0 to 49	curr_prog
<b>PUMP #</b>	Set Pump Number	S	P	N	QPN%03d	Sets the pump number the Tsi is communicating with	0 to 32 (0 is all pumps)	pumpnum
	Set calibration offset	S	P	O	QPO%5.3f	Pump zero offset value. Measure dispense at setting of zero	any float value	offset_value
	Increase calibration offset	S	P	R	N/A	Increase calibration offset		
<b>1/16", 1/20", 1/32", 1/40"</b>	Set screw pitch	Q	P	S	QPS%d	Pump adjustment screw pitch (threads per inch)	16, 20, 32 and 40. Default is 16.	pitch
<b>VMP MICRO OR VMP BORE</b>	Set pump type	S	P	T	QPT%d	Pump Hinge Type	1 = VMP micro, 2 = VMP	pump_type
	Set bore units	S	P	U	QPUI or QPUM	Units for pump bore	1 = Imperial (inches). M = Metric (cm)	units
<b>% MOTOR CURRENT</b>	Pump Drive Current	S	P	V	N/A	Pump motor drive current as a percentage	0 to 100 percent (default is 100)	dac
	Decrease calibration offset	S	P	W	N/A	Decrease calibration offset		
	Increase gain	S	P	Y	N/A	Increase gain value by 0.005		
	Decrease gain	S	P	X	N/A	Decrease gain value by 0.005		
<b>INFINITY SIGN</b>	Run in Continuous mode	S	R	C	QRC or ORN	Continuous run mode	0 = single shot, 1 = continuous	ContinuousMode
<b>RPM -</b>	Discernment current speed	S	R	D			60 to 1000	spd
<b>RPM +</b>	Increment current speed	S	R	I			60 to 1000	spd
<b>ORANGE BUTTON WITH 1 INSIDE GREEN BUTTON WITH &gt; INSIDE</b>	Run in normal mode	S	R	N		This causes an Abort to occur.		ContinuousMode
	Run Program	S	R	P		Run the current program		N/A
<b>SEND BUSY/READY END CYCLE PULLBACK DELAY</b>	Set Ethernet Run Ready	S	R	R	QR%c	QRB if motor is running else QRR	0 or 1	EthernetrunReady
	End of Cycle pullback delay	S	R	U		Ms delay after loop prog & before pullback	0-32000	endOfCycleDelay
<b>END CYCLE PULLBACK RPM</b>	End of cycle pullback RPM	S	R	V		Cycle pull back RPM	5 - MaxSpeed	cyclePullbackRPM

<b>END CYCLE PULLBACK</b>	End of cycle pullback	S	R	W		Cycle pull back	0 - MaxCycles	cyclePullback
<b>PULLBACK RPM</b>	Pullback RPM	S	R	X		Pull back RPM	5 - MaxSpeed	pullbackRPM
<b>BACK FORTH/ RED X BUTTON</b>	Agitation RPM	S	R	Y		Agitation Enable/Disable toggle	5 - MaxSpeed	
<b>ACCELERATION</b>	toggle Agitation	S	R	Z		Set acceleration of dispense motor	0 or 1	
<b>REVOLUTIONS</b>	Set dispense acceleration	S	S	A	QSA%03d	Set number of pump revolutions	60 to 200 (Min_Accel to Max_Accel)	accel
<b>DECELERATION</b>	Set max Cycles or revolutions	S	S	C	QSC%04d	Set deceleration of dispense motor	1 to 9999 (0 to MaxCycles)	revs
<b>FINAL RPM</b>	Set dispense declaration	S	S	D	QSD%03d	Set final speed of dispense motor (rpm)	60 to 200 (MinFinalSpeed to MaxFinalSpeed) default 130	decel
<b>INITIAL RPM</b>	Set Final dispense Speed	S	S	F	QSF%04d	Set initial speed of dispense motor (rpm)	60 to 200 (MinInitialSpeed to MaxInitialSpeed) default is 130	final_spd
<b>INFO SCREEN</b>	Set Initial Speed	S	S	I	QSI%04d	Set serial number		initial_spd
<b>PULLBACK</b>	Set serial number	Q	S	N	QSN%s	Set pullback in percent (%) of revolutions		sernum
<b>READY INPUT</b>	Pullback value	S	S	P	QSP%03d	When enable, pump will not respond to start unless ready input is asserted	0 to 999 (0 to MaxPullback) (i.e. 0 -10 revolutions)	pullback
<b>RPM</b>	Safety Ready input interlock	S	S	R	QSR%d	Set programmed dispense speed (rpm)	0 = disabled, 1 = enabled	ready_interlock
<b>TOTAL VOLUME</b>	Set dispense speed	S	S	S	QSS%0d	Shot Total	60 to 1000 (MinSpeed to MaxSpeed) default is 200	spd
	Shot total	Q	S	T	QST%.4f	Set programmed dispense volume. This must be followed by SCS to complete pump adjustment	Query/Read only	shot_val * revs
	Set shot volume	S	S	V	QSV%.75f	Refreshes information to Tsi	0 to 3.402823 × 10 to 38th power	shot_val
	Update the Tsi	S	U	T	N/A			TsiQueryAll(TSIPOINT)

## 3.4 EtherNet/IP

### INDUSTRIAL NETWORK PROTOCOL DESIGNED FOR REAL TIME COMMUNICATION BETWEEN ALL DEVICES, NOT JUST THOSE CONNECTED TO CONTROLLERS.

Ethernet /IP allows our end user to control processes in real time, utilizing the key elements of User Datagram and Protocol (UDP). In an ecosystem of technology, Control Engineers rely on I/O messaging and data transport, yet need the individual control of program settings, on each device.

#### 3.4.1 Connecting to EtherNet/IP

The easiest way to get started communicating with the pump over Ethernet is to plug the pump into the same network as your computer and turn **DHCP "ON"**.

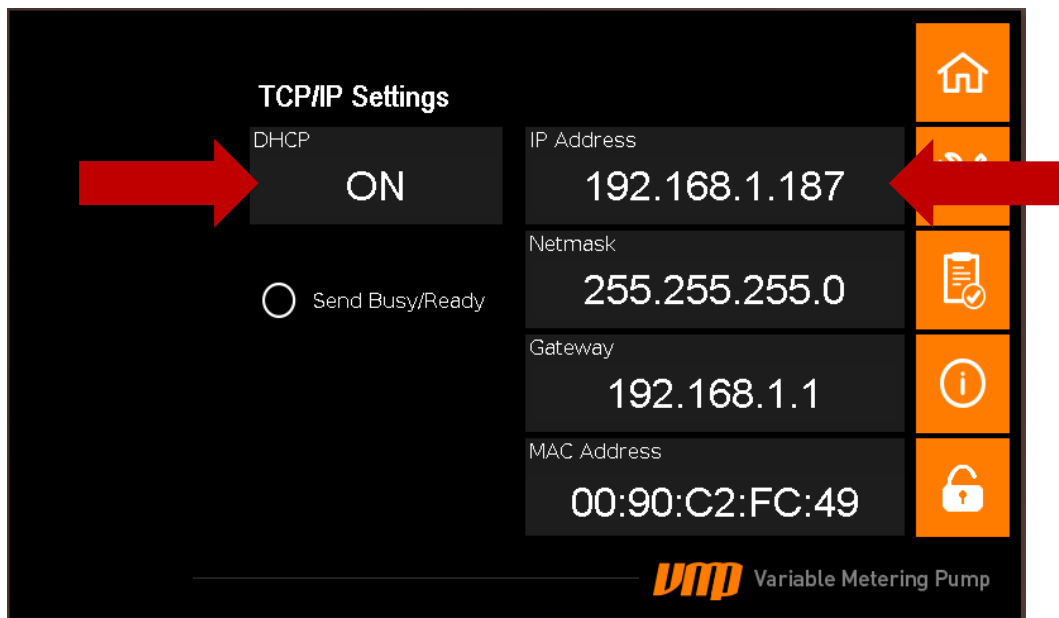

In your preferred serial terminal program, such as RealTerm, type your Smart Pump's IP Address on port 23 to connect to your pump. This is shown in the image below in the Port text box where the IP Address of the pump is followed by "":23".

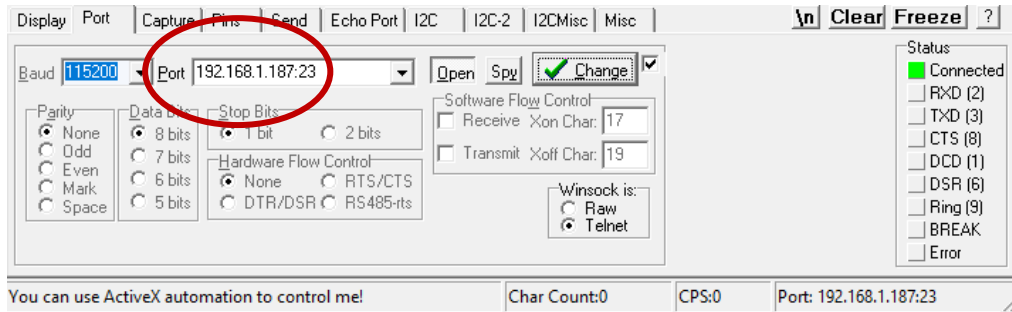

- le. [SRP] will run the dispense motor on your pump that you are connected to.
- le. [SCS] will set the current shot volume on the pump that you are connected to.

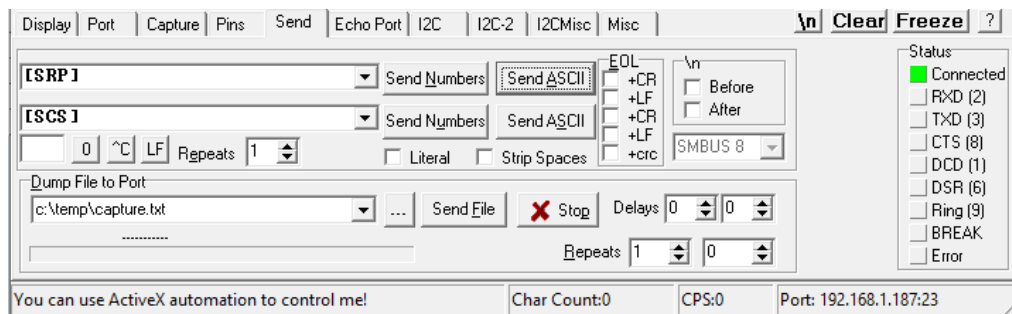

### 3.4.2 EtherNet/IP Commands

The syntax for communicating over Ethernet is "[ +command+ ]" .

TSI BUTTON	SHORT DESCRIPTION	INPUT STRING	QUERY RETURN STRING	COMMENTS	RANGE OR LIMITS	STOREDPARAMS OR STOREDPUMPPARAMS OR CALDATA
<b>RED BUTTON WITH X IN IT</b>	Abort	~ ~ ~ S ~ ~	N/A	Aborts currently running program	If motor enable any set command is ignored Only the first ~ is required.	Abort set to 1
	Adjust Acceleration	S A A	QAA%02d	Adjust Acceleration	Between Min_Accel and Max_Accel	adjust_accel
	Adjust Deceleration	S A D	QAD%02d	Adjust Deceleration	Between Min_Accel and Max_Accel	adjust_decel
	Adjust Initial Speed	S A I	QAI%04d	Adjust Initial Speed	Between MinInitialSpeed and MaxInitialSpeed	adjust_initial_spd
	Adjust Speed	S A S	QAS%04d	Adjust Speed	Between MinAdjustSpeed and MaxAdjustSpeed	adjust_spd

	Adjust A/D Voltage	S	A	V	QAV%03d	Adjust A/D converter voltage	0 to 100	adjust_dac
	Set Baud Rate	S	B	R	QBR%ld	Sets baud rate for serial communications. Baud reate must be set to 115200 if using TSi	96, 192, 384, 576, 1152 Trailing zeros are ignored	baud
	Discernment fine adjust	S	C	D	QCD%3d	Moves the adjust motor down 1 or more steps, decreasing the shot size.	20 to -20	fineAdjust
	Increment fine adjust	S	C	I	QCI%3d	Moves the adjust motor up 1 more steps, increasing the shot size.	20 to -20	fineAdjust
<b>CLEAR FLAG FAULT</b>	Clear motor fault flag	S	C	F		Pump and adjust motor fault flag clear		
<b>PRE-PUMP CLAMP</b>	Set pre pump clamp time	S	C	G	QCG%d	Pre pump clamp ms		preBusyDelay
<b>POST PUMP CLAMP</b>	Set post pump clamp time	S	C	H	QCH%d	Post pump clamp ms		postBusyDelay
<b>PROG</b>	Set current program number	S	C	P	QCP%02d	Change to indicated program number	0 to 49	curr_prog
<b>EQUAL/NO T EQUAL SIGN BUTTON TOTAL</b>	Set current program shot	S	C	S	N/A	Pump adjusts volume to current program setting. Same as SCZ command.	Between offset_count and MaxShot	curr_adj_steps
	Query current Volume	Q	C	V	QCV%7.5f	Query only value		setpoint
<b>FINE ADJUST ZERO OUT DIRECTION</b>	Clear Find Adjust	S	C	Z	N/A	Clear fine adjust and goes to home position. Same as the SCS command.		prog_adj_steps
	Set rotation direction clockwise	S	D	C	QDC	Set pump rotation direction clockwise. (Arrow points up)		dir
<b>DHCP</b>	Toggle DHCP	S	D	H	QDH0 or QDH1	If DHCP is on it is turned off, if off it is turned on	default is off. 0 = off, 1 = on	toggleDHCP()
	Calculate dispense time	S	D	T	QDT%ld			dispensetime
<b>DIRECTION</b>	Set rotation direction counterclockwise	S	D	W	QDW	Set pump rotation direction counterclockwise. (Arrow points down)		dir
<b>INFO SCREEN</b>	Query Firmware revision	Q	F	R	QFR%5.3f	QFR - returns firmware revision number		
<b>GATEWAY</b>	Set I/P gateway	S	I	G	QIG%s	DHCP is turned off before setting the gateway	default 192.168.1.1	IpGateway
<b>MAC ADDRESS</b>	Query Ethernet MAC address	Q	I	M	QIM<mac>	MAC address. QIMxx:xx:xx:xx:xx:xx		MAC Address
<b>NETMASK</b>	Set I/P network mask	S	I	N	QIN%s	DHCP is turned off before setting the mask	default 255.255.255.255	IpNetmask
<b>IP ADDRESS</b>	Set I/P address	S	I	P	QIP%s	DHCP is turned off before setting the address	default 192.168.1.130	IpAddr



	Reset Parameters	S	I	R	N/A	Resets pump to default parameters		
<b>LOOP CYCLES</b>	Loop Cycles	S	L	C	QLC%06l	Number of times to execute program loop	1 to 999999	loopcycles
<b>LINK TIME DELAY</b>	Loop Delay	S	L	D	QLD%05d	Delay, in seconds, before executing next program loop	0 to 32767	delay
	Set Fault	S	L	F	QLF%c	Set dispense fault 1=Fault, 0=No fault		
<b>HOLD ON FAULT</b>	Set Hold on Fault	S	L	H	QLH%c	Set hold on fault 0=No, 1=Yes		
<b>PROG. LINKING / LINKED PROGRAM SET PUMP NUMBER</b>	Next in loop	S	L	N	QLN%02d	Next program to execute at end of current program (-1 to disable)	-1 to MaxProgs	nextprog
	Learn Pump number	S	L	P	QLP%03d	Used in multi-pump applications. Send this command, and then close the external start (foot switch) contact of the pump to save the new number.	MinPumpNumber to MaxPumpNumber	setPumpNum() pumpnum
<b>MAX</b>	Set maximum dispense shot	S	M	S	N/A	Pump adjusts volume to a maximum setting.		MaxShot
<b>NAME</b>	Change current program name	S	N	P	QNP%5s	Names the current program	1 to 15 ASCII printable characters excluding	ProgName
<b>GAIN</b>	Set Gain	S	P	A	QPA%6.5f	Current gain value		gain
<b>BORE</b>	Bore size	S	P	B	QPB%6.4f	Pump Bore	0 to 3.402823 × 10 to 38th power	bore
<b>CALIBRATION FACTORS</b>	Calibration variable 0	S	P	C	QPC%6.4f	Set calibration variable. E.g. the distance in inches from the hinge to the spherical bearing	0 to 999999.0	sphericalbearing
	Calibration variable 1	S	P	F	QPF%6.4f		sphericalbearing	
	Calibration variable 2	S	P	G	QPG%6.4f		sphericalbearing	
	Calibration variable 3	S	P	H	QPH%6.4f		sphericalbearing	
	Calibration variable 4	S	P	J	QPJ%6.4f		sphericalbearing	
	Calibration variable 5	S	P	K	QPK%6.4f		sphericalbearing	
	Calibration variable 6	S	P	L	QPL%6.4f		sphericalbearing	
	Calibration variable 7	S	P	M	QPM%6.4f		sphericalbearing	
	Calibration variable 8	S	P	P	QPP%6.4f		sphericalbearing	
<b>ZERO</b>	Zero Offset	S	P	Q	QPQ%d	Cal zero offset		zeroOffset
<b>PROG -</b>	Decrement Current Program	S	P	D	N/A	When program is 0 it becomes 49.	0 to 49	curr_prog
	Pump Errors over Ethernet	S	P	E	QPE%d		0 or 1	PumpErrors
<b>PROG +</b>	Increment Current Program	S	P	I	N/A	When program is 49 it becomes 0	0 to 49	curr_prog
<b>PUMP #</b>	Set Pump Number	S	P	N	QPN%03d	Sets the pump number the Tsi is communicating with	0 to 32 (0 is all pumps)	pumpnum

	Set calibration offset	S	P	O	QPO%5.3f	Pump zero offset value. Measure dispense at setting of zero	any float value	offset_value
	Increase calibration offset	S	P	R	N/A	Increase calibration offset		
<b>1/16", 1/20", 1/32", 1/40"</b>	Set screw pitch	Q	P	S	QPS%d	Pump adjustment screw pitch (threads per inch)	16, 20, 32 and 40. Default is 16.	pitch
<b>VMP MICRO OR VMP BORE</b>	Set pump type	S	P	T	QPT%d	Pump Hinge Type	1 = VMP micro, 2 = VMP	pump_type
	Set bore units	S	P	U	QPUI or QPUM	Units for pump bore	1 = Imperial (inches). M = Metric (cm)	units
<b>% MOTOR CURRENT</b>	Pump Drive Current	S	P	V	N/A	Pump motor drive current as a percentage	0 to 100 percent (default is 100)	dac
	Decrease calibration offset	S	P	W	N/A	Decrease calibration offset		
	Increase gain	S	P	Y	N/A	Increase gain value by 0.005		
	Decrease gain	S	P	X	N/A	Decrease gain value by 0.005		
<b>INFINITY SIGN</b>	Run in Continuous mode	S	R	C	QRC or ORN	Continuous run mode	0 = single shot, 1 = continuous	ContinuousMode
<b>RPM -</b>	Discernment current speed	S	R	D			60 to 1000	spd
<b>RPM +</b>	Increment current speed	S	R	I			60 to 1000	spd
<b>ORANGE BUTTON WITH 1 INSIDE</b>	Run in normal mode	S	R	N		This causes an Abort to occur.		ContinuousMode
<b>GREEN BUTTON WITH &gt; INSIDE</b>	Run Program	S	R	P		Run the current program		N/A
<b>SEND BUSY/READY</b>	Set Ethernet Run Ready	S	R	R	QR%c	QRB if motor is running else QRR	0 or 1	EthernetrunReady
<b>END CYCLE PULLBACK DELAY</b>	End of Cycle pullback delay	S	R	U		Ms delay after loop prog & before pullback	0-32000	endOfCycleDelay
<b>END CYCLE PULLBACK RPM</b>	End of cycle pullback RPM	S	R	V		Cycle pull back RPM	5 - MaxSpeed	cyclePullbackRPM
<b>END CYCLE PULLBACK RPM</b>	End of cycle pullback	S	R	W		Cycle pull back	0 - MaxCycles	cyclePullback
<b>PULLBACK RPM</b>	Pullback RPM	S	R	X		Pull back RPM	5 - MaxSpeed	pullbackRPM
<b>RPM</b>	Agitation RPM	S	R	Y		Agitation RPM	5 - MaxSpeed	
<b>BACK FORTH/ RED X BUTTON</b>	toggle Agitation	S	R	Z		Agitation Enable/Disable toggle	0 or 1	
<b>ACCELERATION</b>	Set dispense acceleration	S	S	A	QSA%03d	Set acceleration of dispense motor	60 to 200 (Min_Accel to Max_Accel)	accel

<b>REVOLUTIONS</b>	Set max Cycles or revolutions	S	S	C	QSC%04d	Set number of pump revolutions	1 to 9999 (0 to MaxCycles)	revs
<b>DECELERATION</b>	Set dispense declaration	S	S	D	QSD%03d	Set deceleration of dispense motor	60 to 200 (Min_Accel to Max_Accel)	decel
<b>FINAL RPM</b>	Set Final dispense Speed	S	S	F	QSF%04d	Set final speed of dispense motor (rpm)	60 to 200 (MinFinalSpeed to MaxFinalSpeed) default 130	final_spd
<b>INITIAL RPM</b>	Set Initial Speed	S	S	I	QSI%04d	Set initial speed of dispense motor (rpm)	60 to 200 (MinInitialSpeed to MaxInitialSpeed) default is 130	initial_spd
<b>INFO SCREEN</b>	Set serial number	Q	S	N	QSN%s			sernum
<b>PULLBACK</b>	Pullback value	S	S	P	QSP%03d	Set pullback in percent (%) of revolutions	0 to 999 (0 to MaxPullback) (i.e. 0 -10 revolutions)	pullback
<b>READY INPUT</b>	Safety Ready input interlock	S	S	R	QSR%d	When enable, pump will not respond to start unless ready input is asserted	0 = disabled, 1 = enabled	ready_interlock
<b>RPM</b>	Set dispense speed	S	S	S	QSS%0d	Set programmed dispense speed (rpm)	60 to 1000 (MinSpeed to MaxSpeed) default is 200	spd
<b>TOTAL VOLUME</b>	Shot total	Q	S	T	QST%.4f	Shot Total	Query/Read only	shot_val * revs
	Set shot volume	S	S	V	QSV%.75f	Set programmed dispense volume. This must be followed by SCS to complete pump adjustment	0 to 3.402823 × 10 to 38th power	shot_val
	Update the TSi	S	U	T	N/A	Refreshes information to TSi		TsiQueryAll (TSIPOINT)

# Operation

MULTIPLE COMMUNICATION OPTIONS ARE AVAILABLE AS STANDARD, INCLUDING PLC/IO, RS485 AND ETHERNET/IP.

## 4.1 TSi Layout

### 4.1.1 TSi Information Screen



The TSi-VC information screen provides the TSi's and eVMP's firmware revisions as well as the serial number. You can always contact Zaxis direct for technical support by Emailing [support@zaxisinc.com](mailto:support@zaxisinc.com) or calling +1 (801) 264-1000.

## 4.1.2 TSi Main Menu (Page 1)

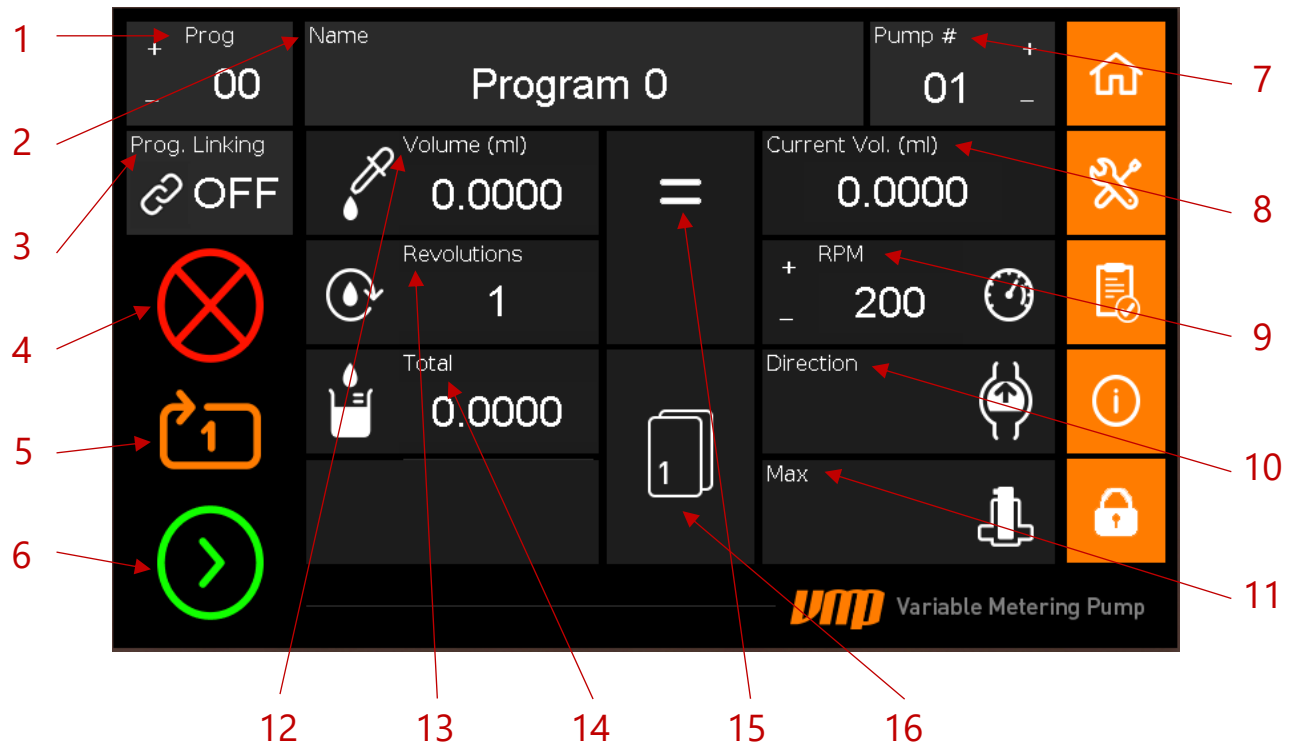

1. Program Number with + - navigation buttons
2. Saved Program Name
3. Program Linking – Changes to Program Linking Screen
4. Stop
5. Dispense Mode (Single/Continuous Shot)
6. Start
7. Pump Number
8. Current Set Volume
9. Rotations Per Minute with + - adjust buttons
10. Dispense Direction
11. Max Shot Quick Adjust
12. Adjust Volume
13. Piston Revolutions per Run Cycle
14. Total Volume – Combining Entered Volume and Revolutions
15. Set Volume
16. Main Menu Page Navigation

## 4.1.3 TSi Main Menu (Page 2)

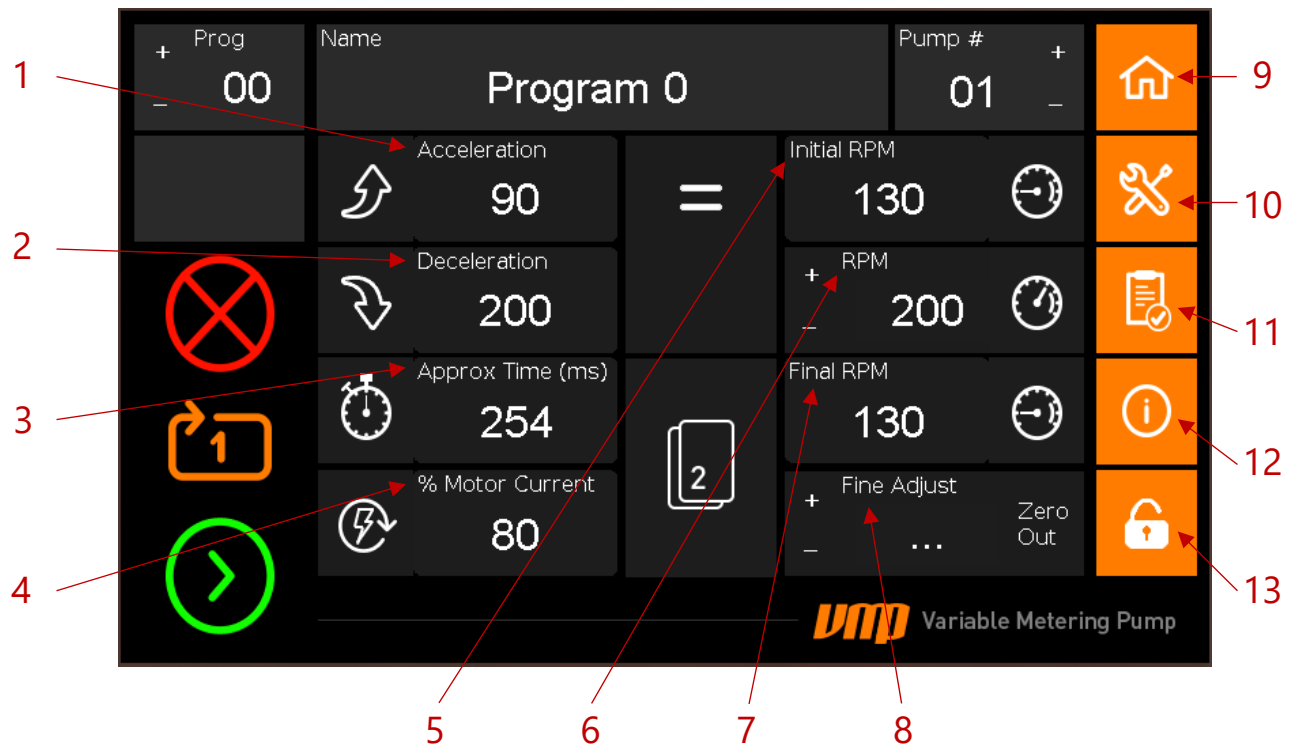

1. Acceleration from Initial RPM to RPM
2. Deceleration from RPM to Final RPM
3. Approximate Time Per Program Cycle
4. % of Motor Current (factory recommendation is 80%)
5. Initial RPM at start up
6. Rotations Per Minute with + - adjust buttons
7. Final RPM at the end of the dosing cycle
8. Fine Adjust with + - adjust buttons
9. Main Menu - Home
10. Settings
11. Checklist
12. Information
13. Lock Volume

## 4.1.4 TSi Program Linking Menu

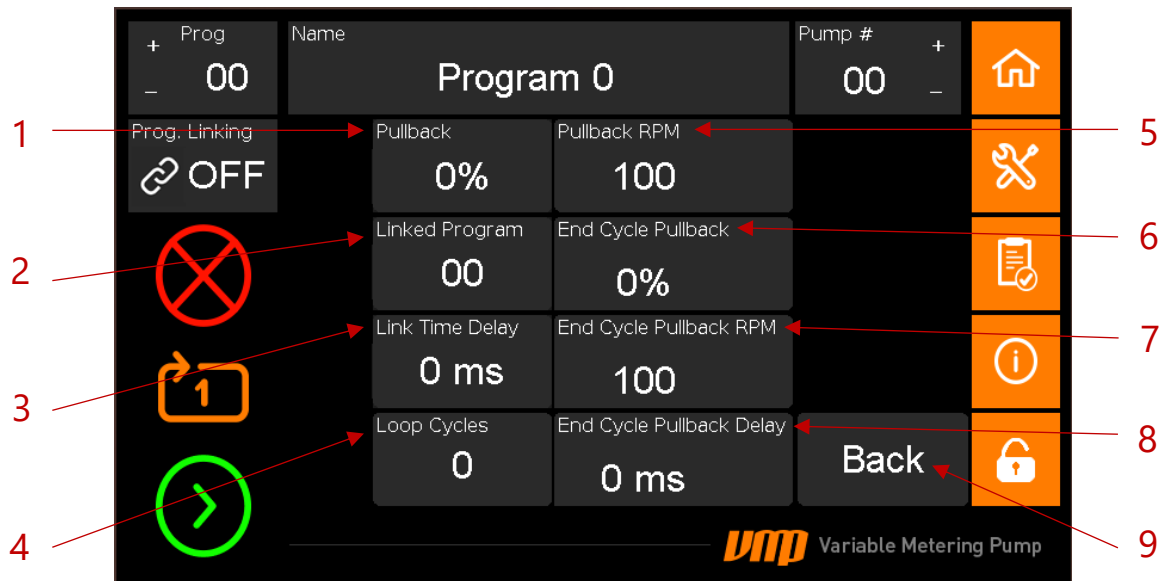

1. Pullback – Suck Back after each shot/piston revolution
2. Linked Program – Keypad to designate the next program to be run in sequence
3. Link Time Delay – Set time between programs
4. Loop Cycles – Designate number of dispense cycles for the selected program.
5. Pullback RPM – Speed of pullback
6. End Cycle Pullback – Suck back after a full cycle of the selected program
7. End Cycle Pullback RPM – Speed of End Cycle Pullback
8. End Cycle Pullback Delay
9. Back – Navigates back to Main Menu Page 1

## 4.1.5 TSi Settings Menu



1. Select Pump Model
2. Auto Agitation - Half rotation of pullback followed by a half rotation of shot.
3. Auto Agitation RPM
4. Piston Head Bore Size
5. Bore Size Confirmation



## 4.1.6 TSi Checklist

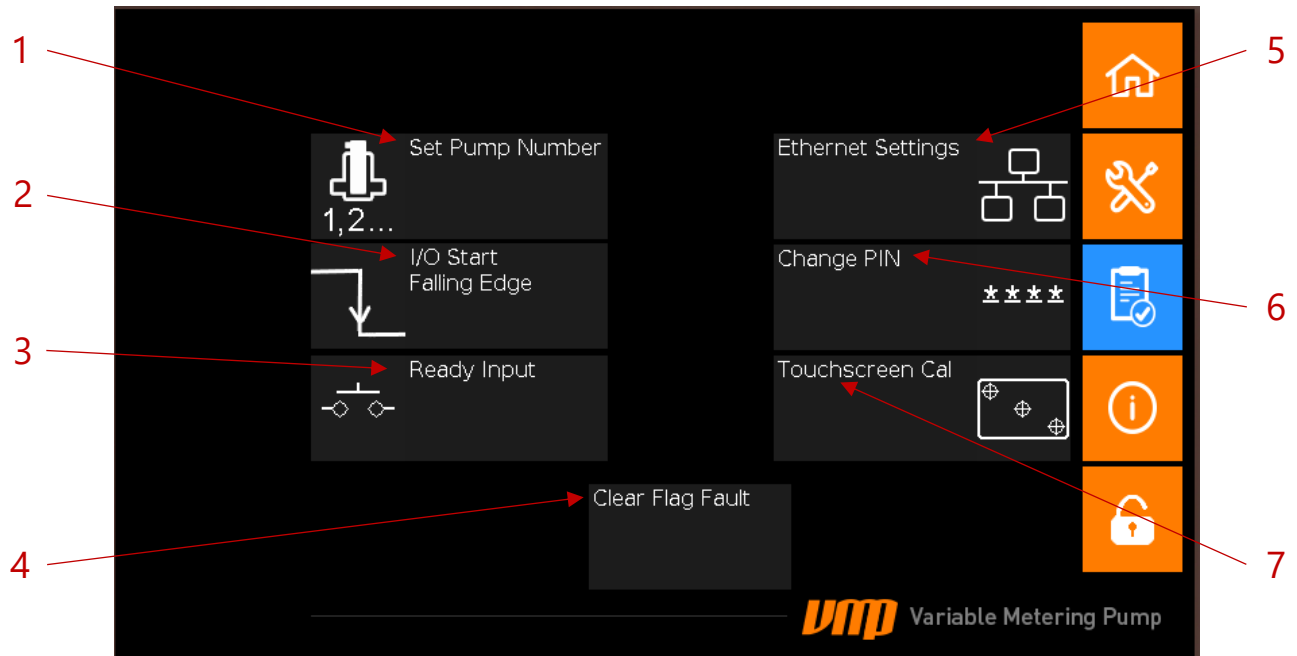

1. Set Pump Number
2. I/O Start (Rising Edge / Falling Edge)
3. Ready Input
4. Clear Flag Fault
5. Ethernet Settings
6. Change Pin
7. Touchscreen Calibration

## 4.2 Functions

### 4.2.1 TSi Main Navigation



**Main Menu:** Control all dispense program settings such as program name, number, dispense volume, dispense speed, program linking, and dispense direction. All pages in the Main Menu contain start, stop, and continuous run functions.



**Settings:** Control pump hardware settings including pump model selection, pump head bore size, and auto agitation.



**Checklist:** Control pump software settings such as pump designation number, ethernet settings, setting the lock function, touchscreen calibration, & the ready input setting.



**Information:** Displays the TSI's and VMP's firmware revisions as well as the serial number.



**Lock Volume:** Locks out the ability to make program or volume changes. This feature does not lock or stop any run function. When the Lock Volume button is selected a keypad will appear. To lock or unlock the pump, enter the PIN number. To edit the PIN number, navigate to the checklist menu.

### 4.2.2 TSi Main Menu (Page 1)



**Start:** Initiate dispense. Will run the current program at the current settings.



**Stop:** Halt dispense. This will stop the pump in the middle of a program or in continuous run mode.



**Dispense Mode:** The 1 in this button indicates a single dispense cycle of the selected program. When selected the color and number 1 changes to an infinity symbol indicating the selected program will run in a continuous loop until stopped.



**Volume:** When the Volume button is selected a keypad will appear. Enter the desired dispense volume in milliliters.



**Current Volume:** The actual volume of the pump after the run button is selected.



**Enter:** When selected the stroke adjustment will move to ZERO then to the set programmed volume.

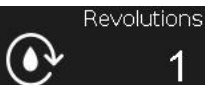

**Revolutions:** When the Revolutions button is selected a keypad will appear. The pump piston rotates 360 degrees per cycle. Enter the desired number of cycles.

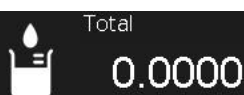

**Total Volume:** Combine the entered volume with the number of revolutions to get the Total Volume.

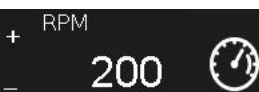

**RPM:** When the RPM button is selected a keypad will appear. Speed can be controlled from 60 to 1000 (1500 for servo motors) Rotations Per Minute. While in continuous mode the speed can be adjusted with the + and - buttons without stopping the pump. Speed and pressure made be limited by fluidics.

Direction



**Direction:** V-Series & VS-Series up and down correlates to the pump head orientation. M-Series pump heads have a horizontal orientation where the down direction on the TSi indicates left to right and the up direction indicates right to left.

Max



**Max Shot:** This button automatically adjusts the stroke to full stroke, or purge. By re-selecting the Max Shot button, or pushing the Enter ( = ) button, the pump will return to the programmed volume.

Name

Program 0

**Program Name:** When the Program Name button is selected a keyboard will appear allowing you to give each program a custom name.

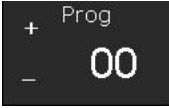

**Pump Number:** When the Program button is selected a keypad will appear. Enter the number of the program you wish to run. Use the + and – buttons to individually move up and down between programs. Up to 50 programs can be saved on a pump at one time.



**Pump Number:** The TSi detachable display will communicate with up to 32 pumps concurrently. A host CPU will communicate with many more. The + and – buttons navigate through all connected pumps in single digit increments. When the Pump Number button is selected a screen will appear showing a list of 32 pumps with radio buttons. Select the radio button of the pump you would like to control. If you would like to make changes to all connected pumps at once select the All Pumps radio button.

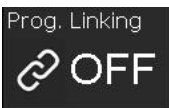
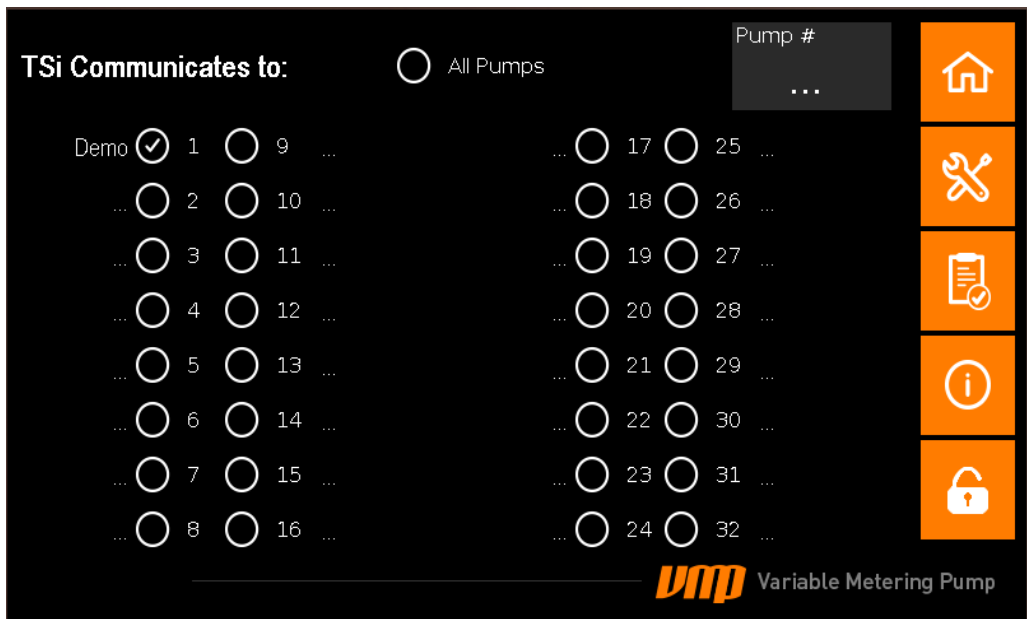

**Program Linking:** This enables you to string programs together. This button brings up the Program Linking sub menu where you can set rotational pullback after a program cycle and designate the next program to be run in a sequence as well as the time between programs and the number of looped cycles per program. Program linking is turned off by factory default

## 4.2.3 TSi Program Linking Menu

Pullback

0%

**Pullback:** Pullback is the percentage of reverse piston rotation after a shot is dispensed. This creates suck back before dispensing the next shot. When the Pullback button is selected a keypad will appear. Enter the percentage of piston rotation for desired suck back.

Pullback RPM

100

**Pullback RPM:** When the Pullback RPM button is selected a keypad will appear. Enter the desired rotations per minute speed for pullback after each shot.

End Cycle Pullback

0%

**End Cycle Pullback:** Standard pullback occurs after each dispense shot (full piston revolution). End Cycle Pull back occurs at the end of the selected program's cycle.

End Cycle Pullback RPM

100

**End Cycle Pullback RPM:** When the End Cycle Pullback RPM button is selected a keypad will appear. Enter the desired rotations per minute speed for pullback at the end of a program's run cycle.

End Cycle Pullback Delay

0 ms

**End Cycle Pullback Delay:** When the End Cycle Pullback Delay button is selected a keypad will appear. Set the pause time in milliseconds between the last shot of a program cycle and the End Cycle Pullback.

Loop Cycles

0

**Loop Cycles:** When the Loop Cycles button is selected a keypad will appear. Select the number of times the currently selected program should loop or repeat before moving on to the next linked program.

Linked Program

00

**Linked Program:** When the Linked Program button is selected a keypad will appear. Enter the number of the next program that should automatically begin.

Link Time Delay

0 ms

**Link Time Delay:** When the Link Time Delay button is selected a keypad will appear. Set the pause time in milliseconds between the last cycle of the current program and the first cycle of the Linked Program.

Back

**Back:** When selected the Back button navigates to Main Menu Page 1.

## 4.2.4 TSi Main Menu (Page 2)



**RPM:** This is the same function that appears on Page 1 of the Main Menu. When the RPM button is selected a keypad will appear. Speed can be controlled from 60 to 1000 Rotations Per Minutes. While in continuous mode the speed can be adjusted with the + and - buttons without stopping the pump. Speed and pressure may be limited by fluidics.



**Acceleration:** Allows you to designate pump acceleration speed from the Initial RPM to the designated dispense cycle RPM in milliseconds/second/second.



**Deceleration:** Allows you to designate pump deceleration speed from the designated dispense cycle RPM to the Final RPM in milliseconds/second/second.



**Initial RPM:** Allows you to designate pump speed at the beginning of each dispense cycle. A dispense cycle can contain 1 or more piston rotations but the Initial RPM only effects the start speed of the first rotation.



**Final RPM:** Allows you to designate pump speed at the end of each dispense cycle. A dispense cycle can contain 1 or more piston rotations but the Final RPM only effects the speed of the last rotation in the cycle.



**Approximate Time per Program:** This calculates the time for a full program cycle when taking into account the RPM as well as the acceleration and deceleration of the rotation and revolutions.



**Fine Adjust with + - Buttons:** Use the + and - buttons to make micro adjustments to the stroke length. This makes fine adjustments to shot volume. This function does not save to pump settings, each time you adjust the pump the fine adjustment will be lost.



**% of Motor Current:** The percent of maximum power the pump will use to turn the motor. The manufacturer recommends leaving this setting at 80%. A higher percentage can cause the pump to overheat and degrade over time.

## 4.2.5 TSi Settings Menu



**Select Pump Model:** Radial buttons allow you to set the pump model. For ease of use, connectivity, and interchangeability, the entire eVMP Smart Pump family uses the same firmware. Setting the pump model will be done at the factory and should never need to be adjusted.



**Auto Agitation:** Initiates half rotation of pullback followed by a half rotation of shot in-between dispenses. This agitation function is specifically designed to keep fluids from hardening or crystalizing by keeping the fluid in motion.

RPM

40

**Auto Agitation RPM:** Set the speed of the Auto Agitation process. This is dependent on the properties of the fluid being dispensed.



**Piston Head Bore Size:** This function allows you to change the bore size to correlate with whichever pump head is installed on the pump drive.

Bore

.500

**Bore Size Confirmation:** Confirms the bore size that has been selected.

## 4.2.6 TSi Checklist Menu

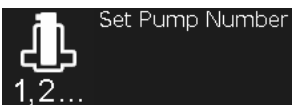

**Set Pump Number:** When the Set Pump Number button is selected a screen will appear showing a list of 32 pump numbers with radio buttons. Select the radio button next to the desired pump number followed by pressing the Send Command button in the top right corner of the screen. To initialize the pump number change you must press the physical **Hard Reset** button on the top rear of the pump drive next to the red LED.

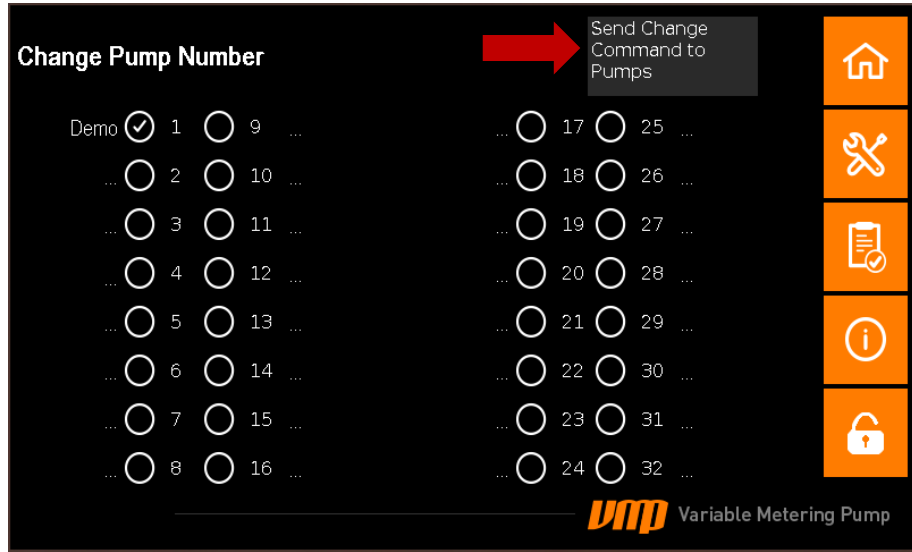

**M, V, or VS Series  
Hard Reset**



**VS6-Series  
Hard Reset**

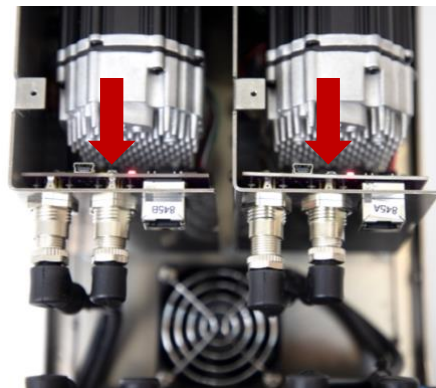

**Dual Enclosure  
Hard Reset**

**Hard Reset:** While holding down the Hard Reset button turn the power on, the red LED will flash 4 times. This will hard reset the pump to factory settings with the exception of pump calibration. Continue to hold the Hard Reset button for 5 seconds and the red LED will flash 3 more times. At this point the RS485 will switch from half-duplex to full-duplex mode.

Pressing the Hard Reset button when the pump is already powered on will reset the pump number to #1 and turn DHCP OFF. Holding the Hard Reset button until you see the LED flash 3 times will reset the pump number to #1 and turn DHCP ON.





Ready Input

**Ready Input:** Ready Input is a safety interlock blocking the pump start signal. When enabled this function will lock the pump and prohibit any operation until the pump's I/O receives a ready signal from a PLC or other outside source. The factory setting for Ready Input is Closed or Off. See section 3.1 on PLC Communication for detailed operating instructions. (See Section 3.2)

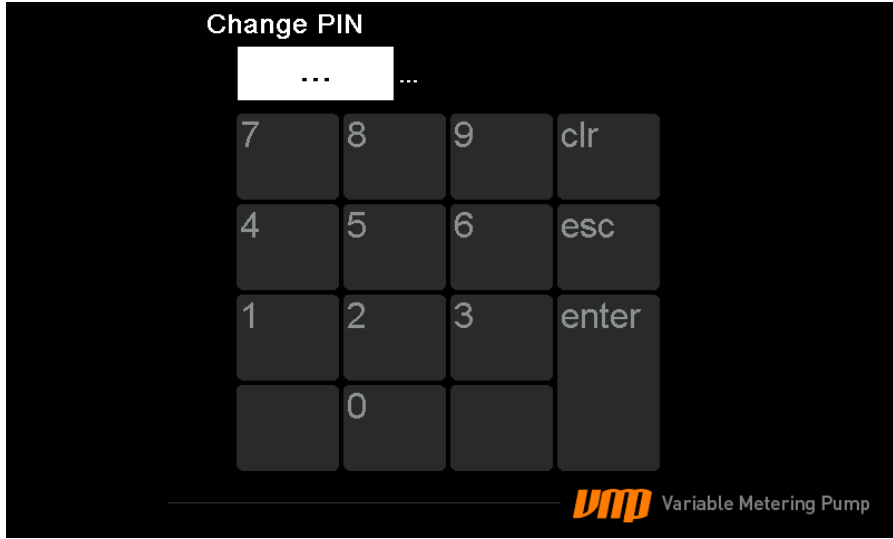

Clear Flag Fault

**Clear Flag Fault:** All Smart Pumps in the eVMP family are designed to stop operation when they experience a flag fault. If the pump experiences a flag fault all pump functions will stop and "-1.0000" will appear in the current volume display on Main Menu Page 1. The clear flag fault function will clear the fault and allow the pump to operate again.

<p>Ethernet Settings</p> 	<p><b>Ethernet Settings:</b> When selected another screen will appear, allowing you to set your IP Address, Netmask, and Gateway. (See Section 3.4)</p>
<p>I/O Start Falling Edge</p> 	<p><b>I/O Start:</b> When Rising Edge is showing, the pump will initialize as soon as the start button is pressed. When Falling Edge is showing, the pump will initialize once the start button is released.</p>
<p>Change PIN</p> <p>****</p>	<p><b>Change Pin:</b> When the Change Pin button is selected a keypad will appear. To change the pin used to lock the pump first the existing pin must be entered. If the pin is blank, simply press enter. Then enter and re-enter the new desired pin.</p> 
<p>Touchscreen Cal</p> 	<p><b>Touchscreen Calibration:</b> If the touchscreen isn't working properly or isn't taking input, calibrating the touch screen is a good option. When Touchscreen Calibration is selected a calibration screen with a small target will appear. Select the target as close to its center as possible. Two more targets will appear in sequence. Once all three targets are selected the screen is calibrated and changes back to the Checklist Menu.</p>

# Maintenance

## 5.1 Consumables

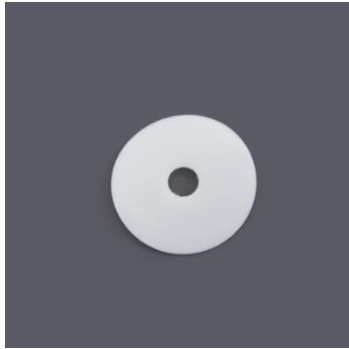

**LIP SEALS**

Lip Seals are used as an optional extra barrier between the fluid path and the pump drive. Choose between PTFE and Rulon® AR lip seals. Consult Zaxis about alternate materials.



**LIP SEAL INSERTION TOOL**

The Lip Seal Insertion Tool's smooth tapered design allows for worry free installation of the sensitive lip seals. The sizes below correspond to your piston size, all M-Series heads use 1/4" OD.



**GLAND WASHER**

The eVmP pumps, V-Series and Micro Series, utilize a simple set of wearable parts. Both the V-Series and the M-Series heads are standard with PTFE washers. Consult Zaxis about alternate materials.

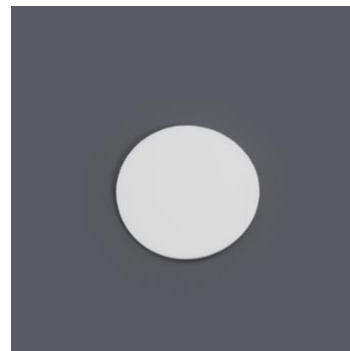

**HEAD SEAL**

The eVmP pumps, V-Series and Micro Series, utilize a simple set of wearable parts. V-Series are standard with PTFE head seals. The Micro CKC pump head does not require a head seal. Consult Zaxis about alternate materials.

## 5.2 Cleaning

### 5.2.1 M-Series

#### Tools, Gages, Fixtures

- #2 Phillips Screwdriver
- Small Channel Locks
- Lip Seal Tool

#### Safety Requirement

- Always wear safety glasses.

#### Consumable Part Numbers

COMPONENT NAME	DESCRIPTION	SIZE	PART NUMEBR
GLAND WASHER	Gland Washer, Teflon	3/16"	101061
		1/4"	101060
LIP SEAL	Lip Seal, Rulon AR	3/16"	101059
		1/4"	100899
LIP SEAL TOOL	Lip Seal Instillation Tool	3/16"	
		1/4"	500071

#### Note

Factory seals are intended to last for thousands of hours in the most demanding applications and are often never replaced if the pump head is regularly used with neat chemicals and aggressive media is removed from the pump head during extended periods of down or off time.

### STEP 1

First make sure the pump is adjusted to a volume of 0 (this will make removing the head easier), then use a #2 Phillips screwdriver to remove the head cap screws and the pump head cap.



## STEP 2

With the pump head cap removed, gently remove the pump head from the pump drive.

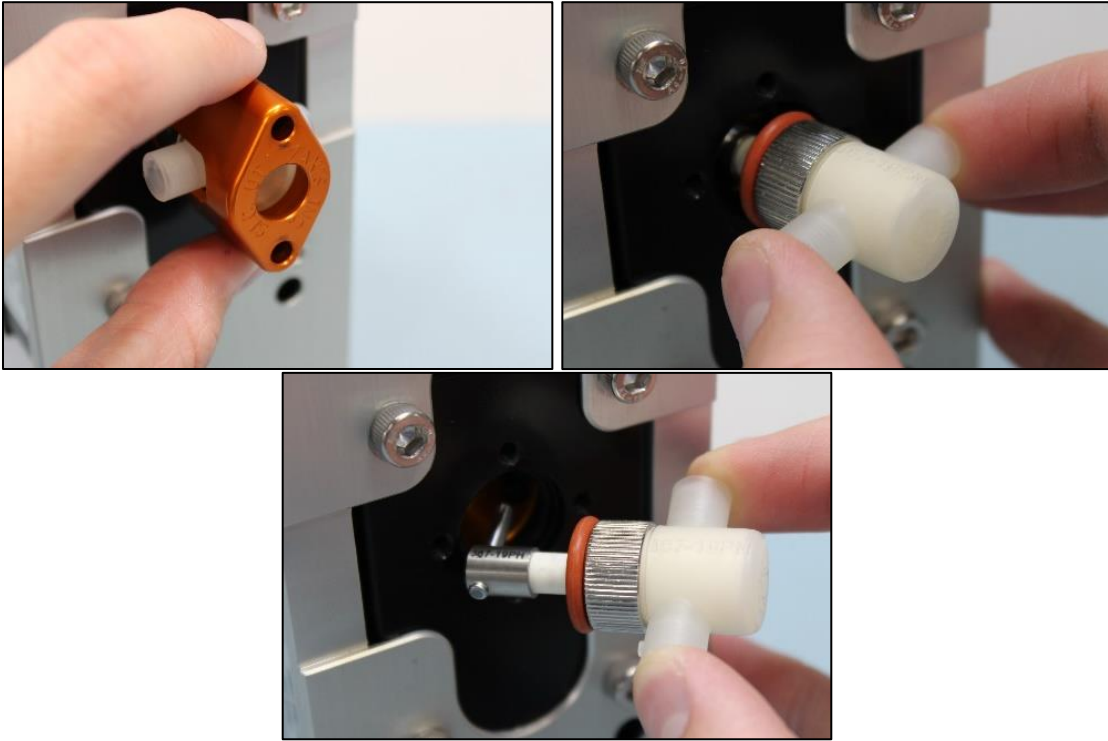

## STEP 3

Now that the pump head has been removed, use a small pair of channel locks to loosen the gland nut and remove it and the piston from the pump head body.

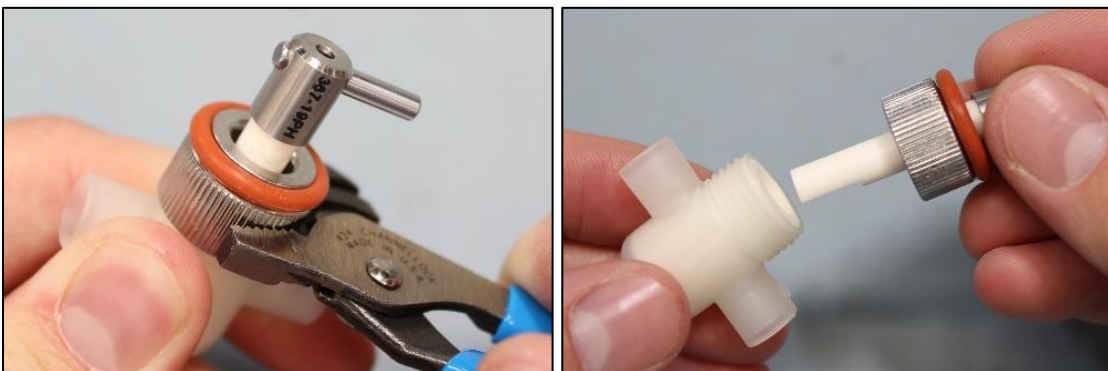

## STEP 4

Then remove the gland nut from the piston, the lip seals and gland seal will be removed with the gland nut. The lip seals and gland seal are the only parts that should need replacing in a standard pump head service.

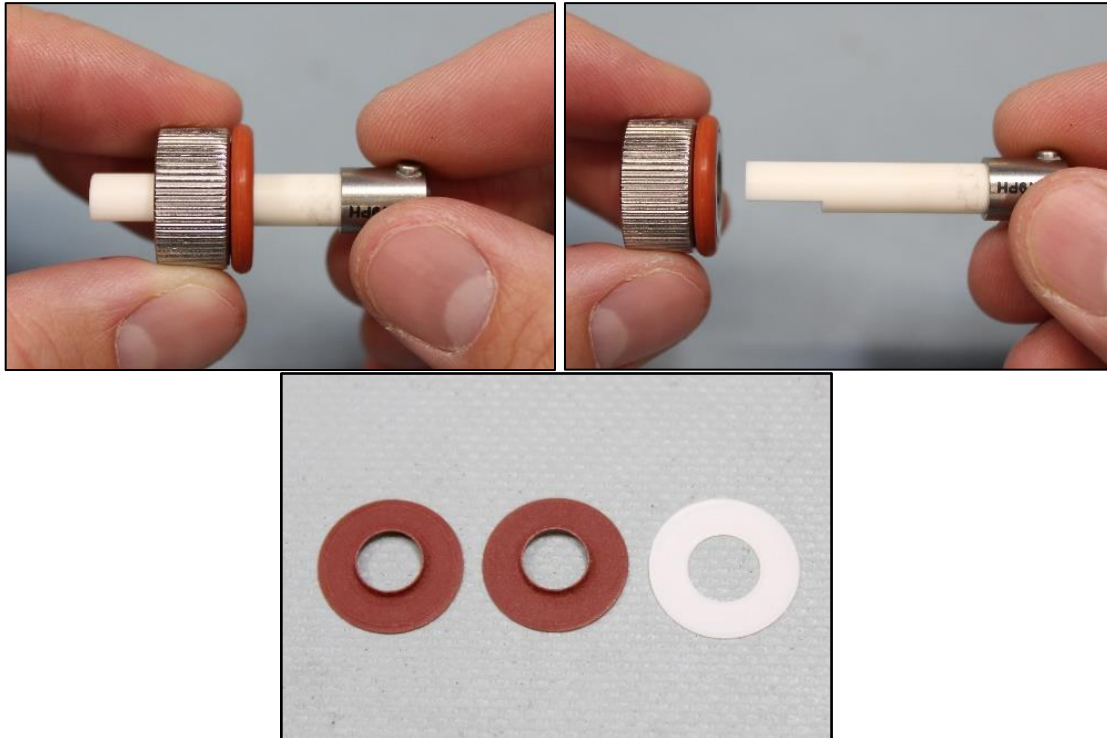

## STEP 5

With the old lip seals and gland washer removed the new ones can be installed. Begin by installing the lip seal tool onto the piston. Then insert the piston into the gland nut and install the new gland washer.

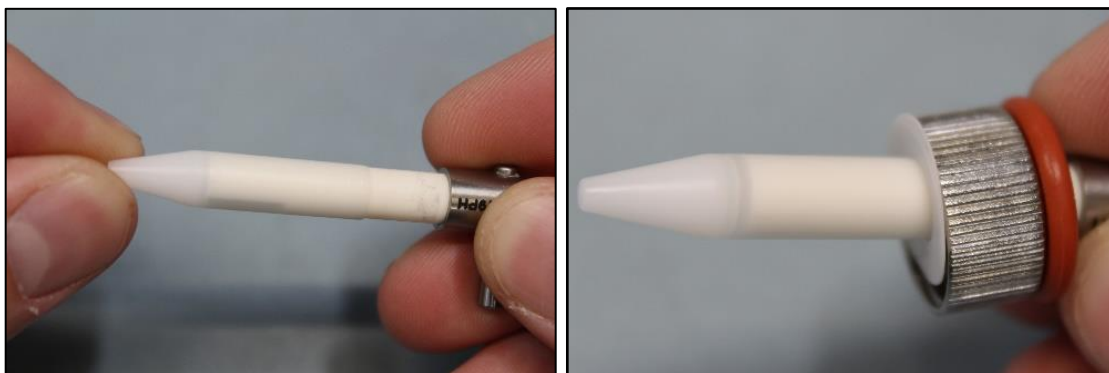

## STEP 6

Next install the first lip seal with the collar of the lip seal towards the gland nut. Then install the second lip seal with the collar away from the gland nut.

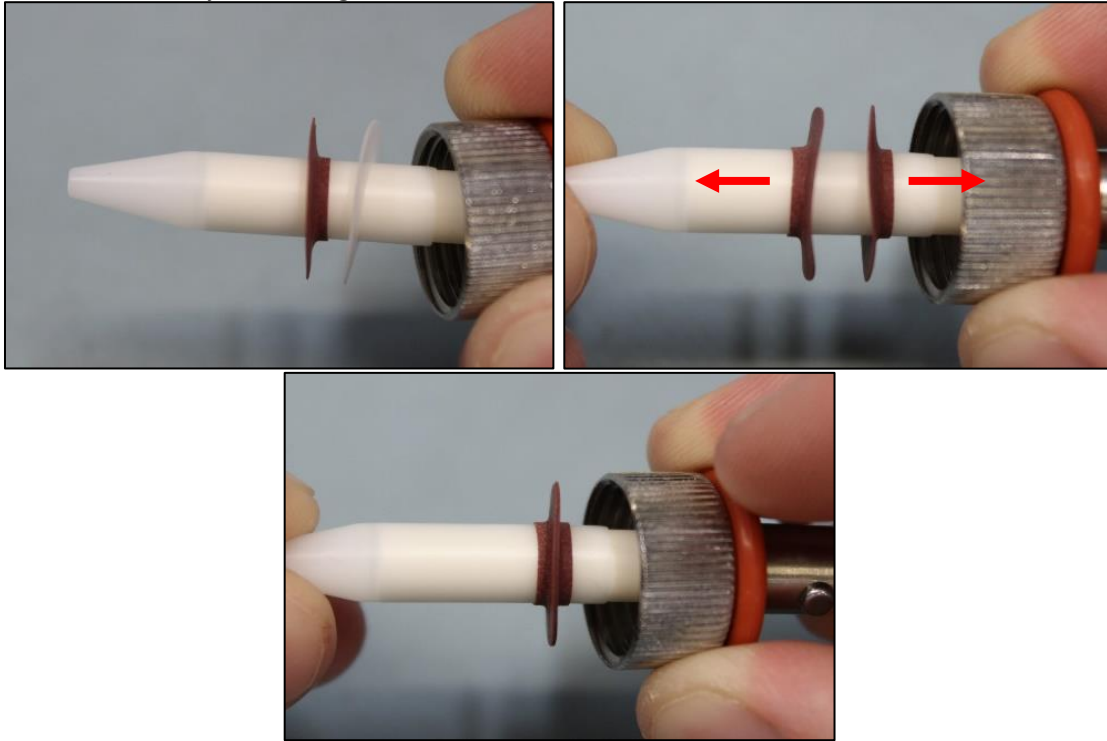

## STEP 7

Push the lip seals further onto the piston until they are free of the lip seal tool, then remove the lip seal tool.

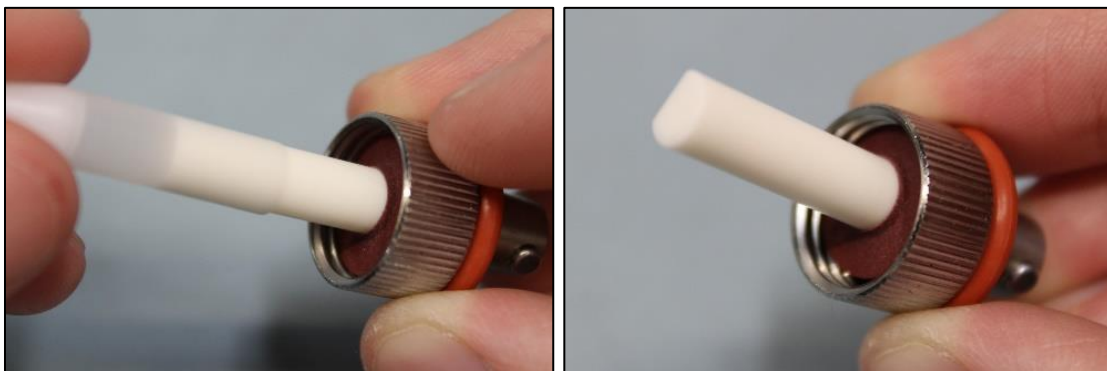

## STEP 8

Now the piston can be reinstalled into the pump head body. Push the piston all the way into the pump head body and tighten the gland nut by hand.

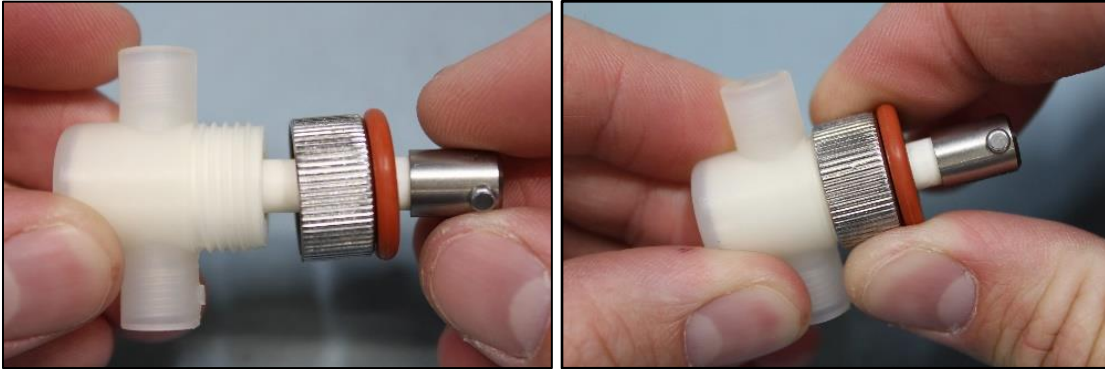

## STEP 9

Use a pair of small channel locks to tighten the gland nut 1/8th of a rotation and the pump head is ready to be reinstalled.

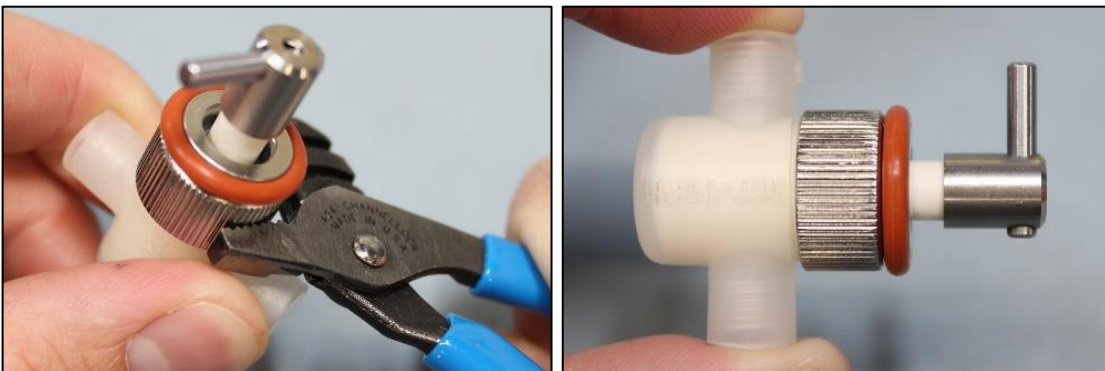

## STEP 10

Begin the reinstall of the piston by inserting the drive pin of the piston into the bearing of the spindle on the pump drive. Once the pin is in the bearing, push the pump head into the recessed pocket on the hinge

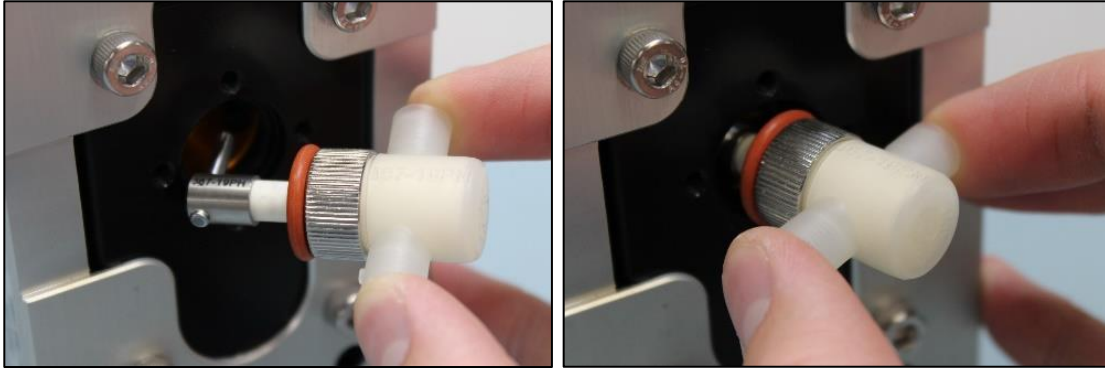

## STEP 11

With the pump head installed on the drive the pump head cap can be reinstalled. Use a #2 Phillips screwdriver to install the (2) pump head cap screws.

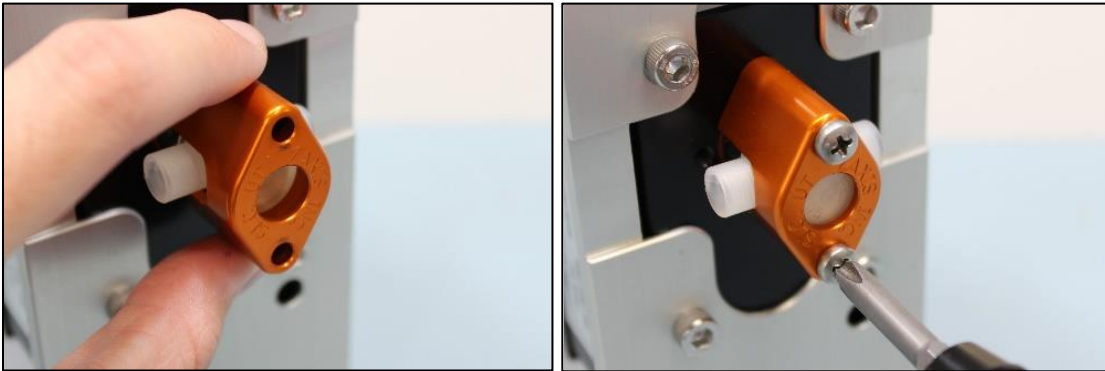

## STEP 12

12.0 This concludes the Micro Pump Head Service Instructions. The pump is now ready to dispense.





## 5.2.2 V-SAN

(V-Series & VS-Series)

### Tools, Gages, Fixtures

- 3mm L-Hex Wrench
- 14mm Hex Socket
- Torque Wrench Capable of 6 ft-lbs of Torque

### Safety Requirement

- Always wear safety glasses.

### Consumable Part Numbers

COMPONENT NAME	DESCRIPTION	SIZE	PART NUMEBR
<b>GLAND WASHER</b>	Gland Washer, Teflon	1/4"	200107
		3/8"	200108
		1/2"	200089
<b>LIP SEAL</b>	Lip Seal, PTFE	1/4"	200109
		3/8"	200010
		1/2"	200090
<b>LIP SEAL TOOL</b>	Lip Seal Instillation Tool	1/4"	500071
		3/8"	500080
		1/2"	500081

### Note

Factory seals are intended to last for thousands of hours in the most demanding applications and are often never replaced if the pump head is regularly used with neat chemicals and aggressive media is removed from the pump head during extended periods of down or off time.

## STEP 1

Begin by removing the (2) bolts that hold the head to the pump using a 3mm L-Hex Wrench and removing the pump head from the drive



## STEP 2

With the pump head removed, use a 3mm L-Hex Wrench to remove the (4) bolts holding the base plate of the pump head to the body.

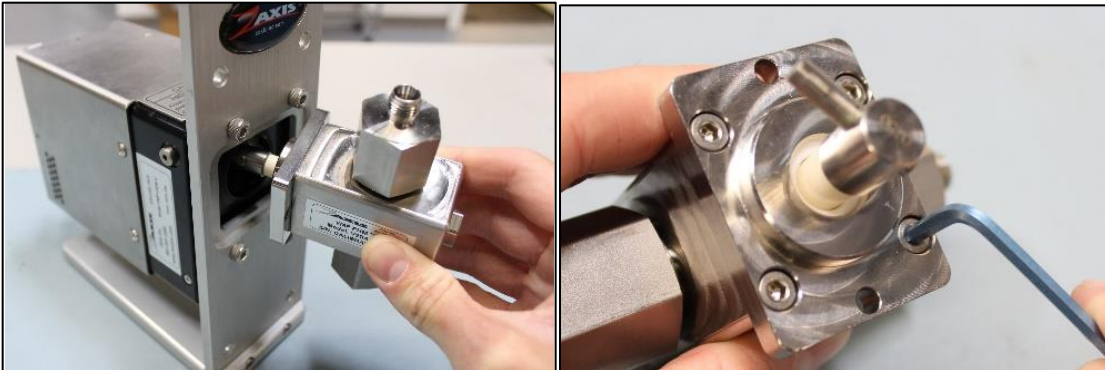

### STEP 3

Remove the piston and the base plate from the pump head body.

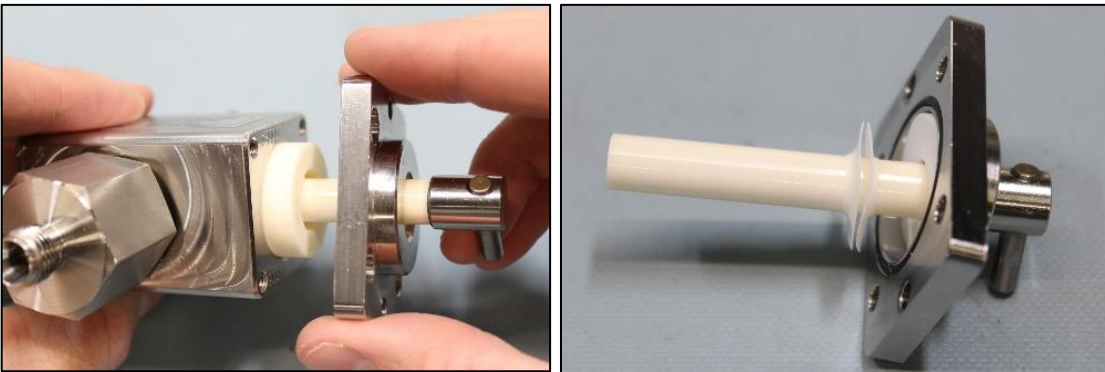

## STEP 4

Remove the (2) lip seals from the piston, these should be the only parts that will need replacing in a standard service.

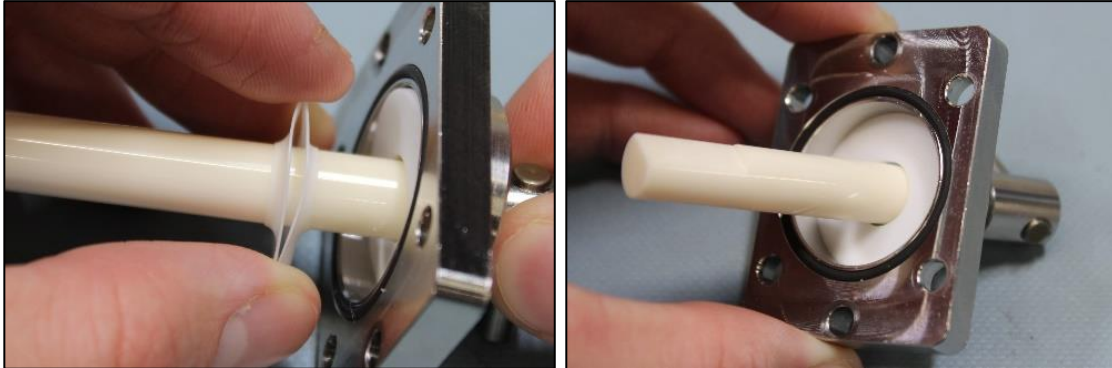

## STEP 5

Now the new lip seals can be installed. Start by installing the lip seal tool over the end of the piston. Then install the first lip seal with the flared collar pointed towards the base plate.

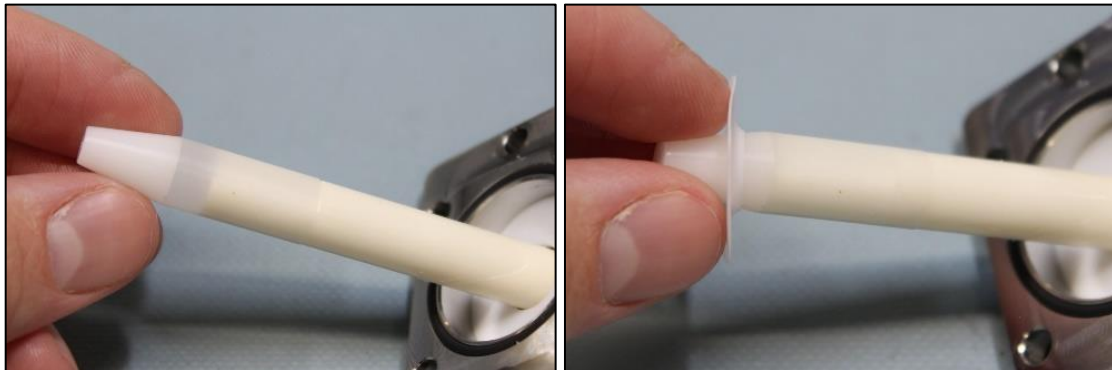

## STEP 6

Next install the second lip seal with the flared collar pointing away from the base plate (opposite of the direction of the first lip seal).

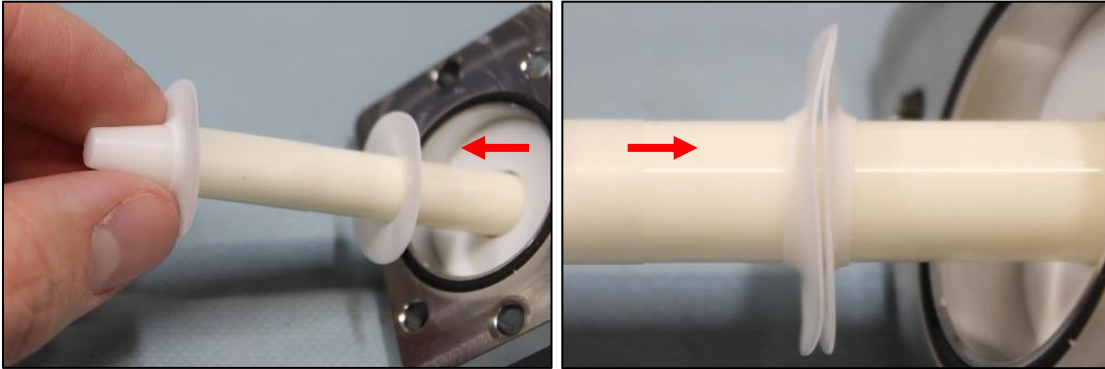

## STEP 7

With the new lip seals installed the lip seal tool can be removed. Then before reinstalling the piston into the liner, use a 14mm socket to loosen the head cap a ¼ turn.

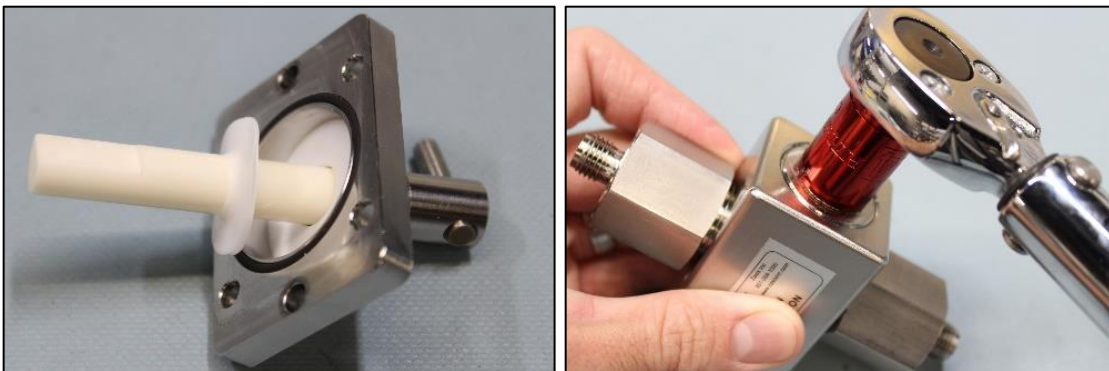

## STEP 8

Then reinstall the piston into the liner and secure the base plate to the pump head body using a 3mm L-Hex Wrench.

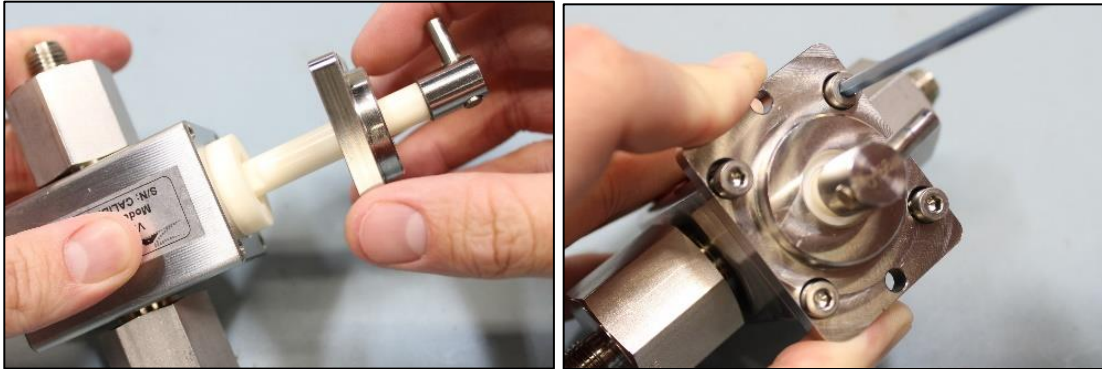

## STEP 9

Finally secure the pump head in a position with the head cap accessible and torque the head cap to 6 ft-lbs. This completes the pump head service.

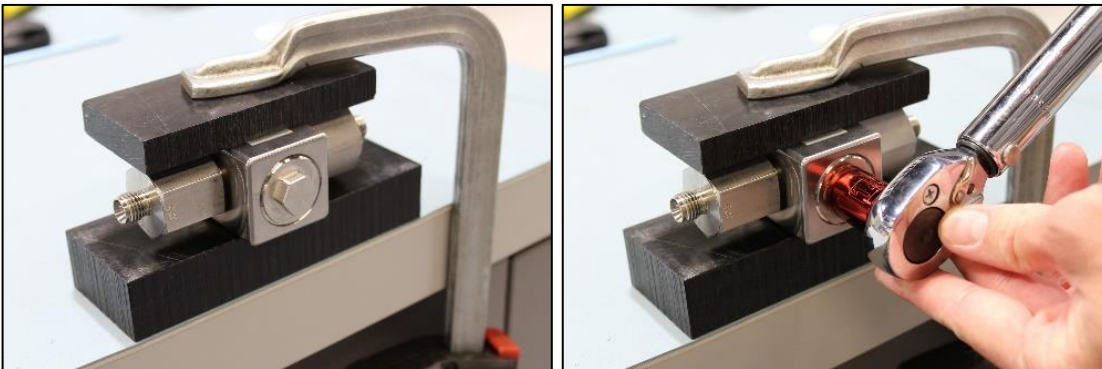

### 5.2.3 VS6-Series

#### Tools, Gages, Fixtures

- 5mm L-Hex Wrench
- Adjustable Wench (size should correspond with pump head fittings in use)

#### Safety Requirement

- Always wear safety glasses.

#### Consumable Part Numbers

COMPONENT NAME	DESCRIPTION	SIZE	PART NUMEBR
GLAND WASHER	Gland Washer, Teflon	1"	200107
PORT SEAL BUSHING	VS6 Pump Head, Port Seal Bushing, PTFE	VS6	200183

**Note**

Factory seals are intended to last for thousands of hours in the most demanding applications and are often never replaced if the pump head is regularly used with neat chemicals and aggressive media is removed from the pump head during extended periods of down or off time.

**STEP 1**

Begin by removing the (4) bolts that hold the head to the pump using a 5mm L-Hex Wrench and removing the pump head from the drive

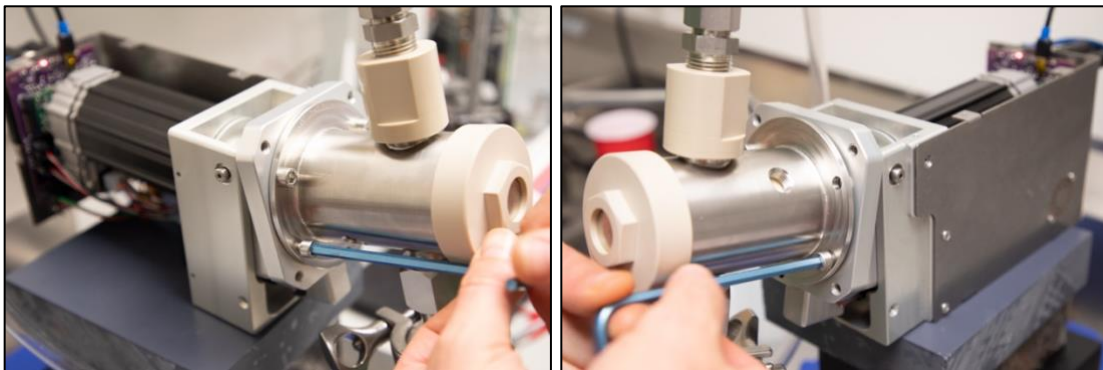
**STEP 2**

Loosen the cap seal of the pump head, this piece is only hand tight and should be able to be removed without tools.

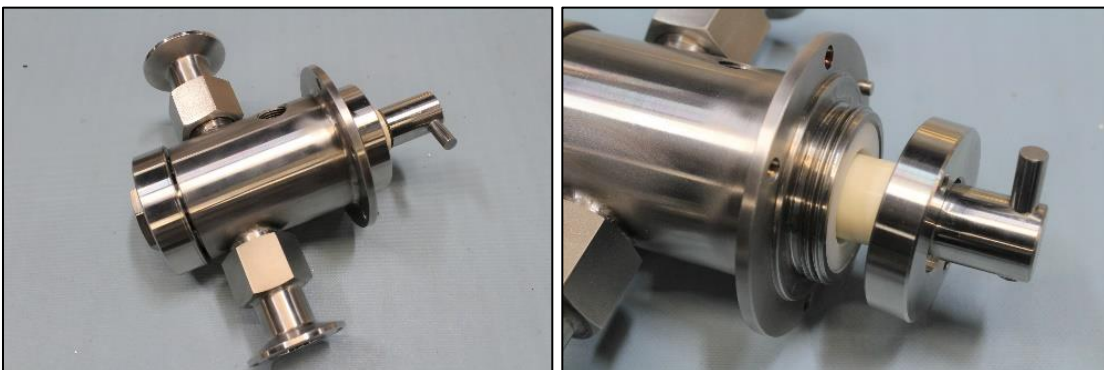
**STEP 3**

Next remove the cap seal and the piston from the pump body. The cap spacer and the gland seal will come off with the piston when removed.

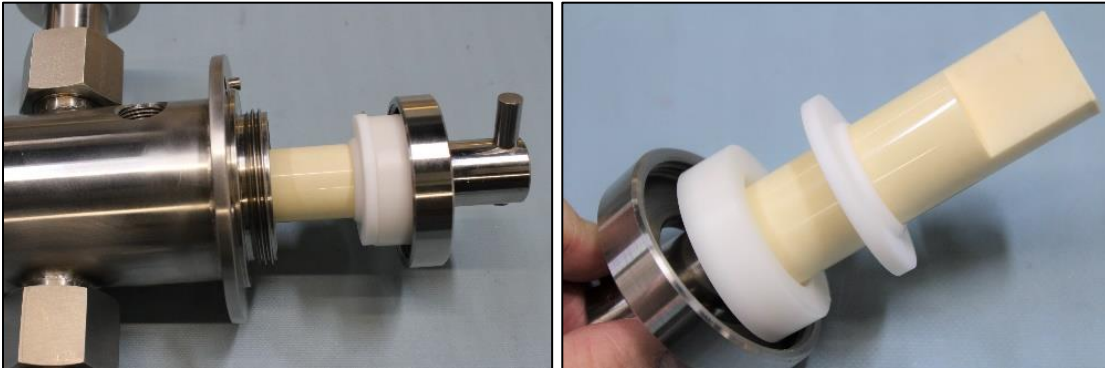

#### STEP 4

Then remove the old gland seal, this should be the only piece that needs to be replaced in a standard service.

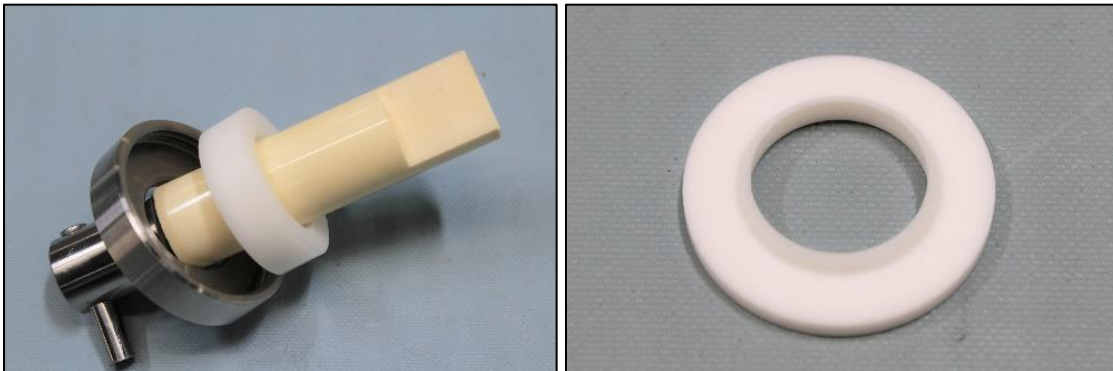

## STEP 5

Install the new gland seal with the collar pointed away from the base plate and reinstall the piston into the pump body.

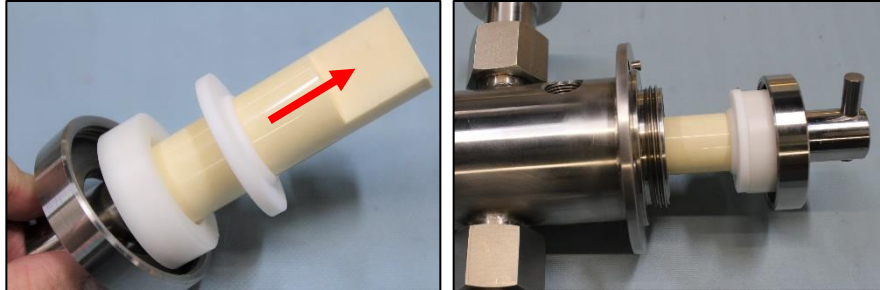

## STEP 6

Push the piston and base plate into the pump head then tighten the cap seal to the pump head body. The cap seal should be hand tight. This completes the V6SAN pump head service instructions the pump head is now ready to dispense.

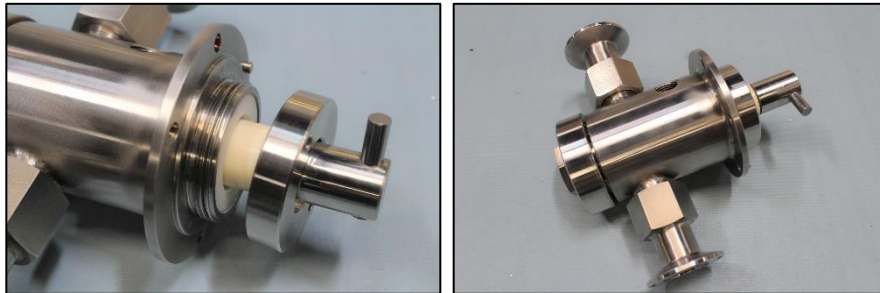



# Specifications

ZAXIS' INSTRUMENTS ARE BUILT TO MEET A DYNAMIC MANUFACTURING ENVIRONMENT.

## 6.1 M-Series

### 6.1.1 M-Series Specifications

<b>Dimensions</b>	2.8" wide, 4" high, 5.7" deep	The Micro is the most compact eVmP Smart Pump, designed for small precision dispenses. These dimensions reflect the Micro drive without an attached pump head.
<b>Weight</b>	5lbs (with pump head)	The Micro is the most compact eVmP Smart Pump, designed for small precision dispenses.
<b>System Power</b>	24 VDC 2 Amps	Universal power requirements allowing us to ship testers all over the world.
<b>Pressure Range</b>	Up to 100 PSIG	
<b>RPM</b>	1000	
<b>Dispense &amp; Flow Range</b>	Head Size: M0	Up to 0.05mL/rev or 50mL/min
	Head Size: M1	Up to 0.10mL/rev or 100mL/min
<b>Media Compatibility</b>	Most acids and bases, water-like to slurry, monomers and some polymers	Ideal for food, pharma, and bio processes. Custom pump head materials are available.
<b>Wetted Path Options</b>	Ceramic (Medical grade alumina-oxide), 316SS, 303/304SS, PVDF, PEEK, Customization Available	Custom pump head materials are available.
<b>Operational Temps</b>	-20°C – 70°C, non-condensing	

<b>Operational Types</b>	Continuous Metering, Single/Multiple Dispense, Flow Direction, & Suck Back	The eVmP Smart Pump has been developed with versatility in mind. Our goal is to help you dispense what you want how you want.
<b>Stored Programs</b>	Up to 50	Run multiple parameters through a single pump.
<b>Interface</b>	EtherNet/IP, Ethernet TCP/IP, RS485, Digital I/O, 1/2 or Full Duplex	Multiple communication options specific to your application. See Section 3 on Communication
<b>Accuracy &amp; Repeatability</b>	1% +/- Full Scale, 0.5 CV	High accuracy and repeatability

### 6.1.2 M-Series Pump Drives

The eVmP Micro is our stepper motor drive, designed for the Micro Series pump heads. Micro Pumps are ideal for neat chemistry, with flow rates under 100 mL/min, and pressure less than 100 PSIG and CKC pump heads. Each Micro Drive is standard with RS485, Digital I/O, and Ethernet connections.

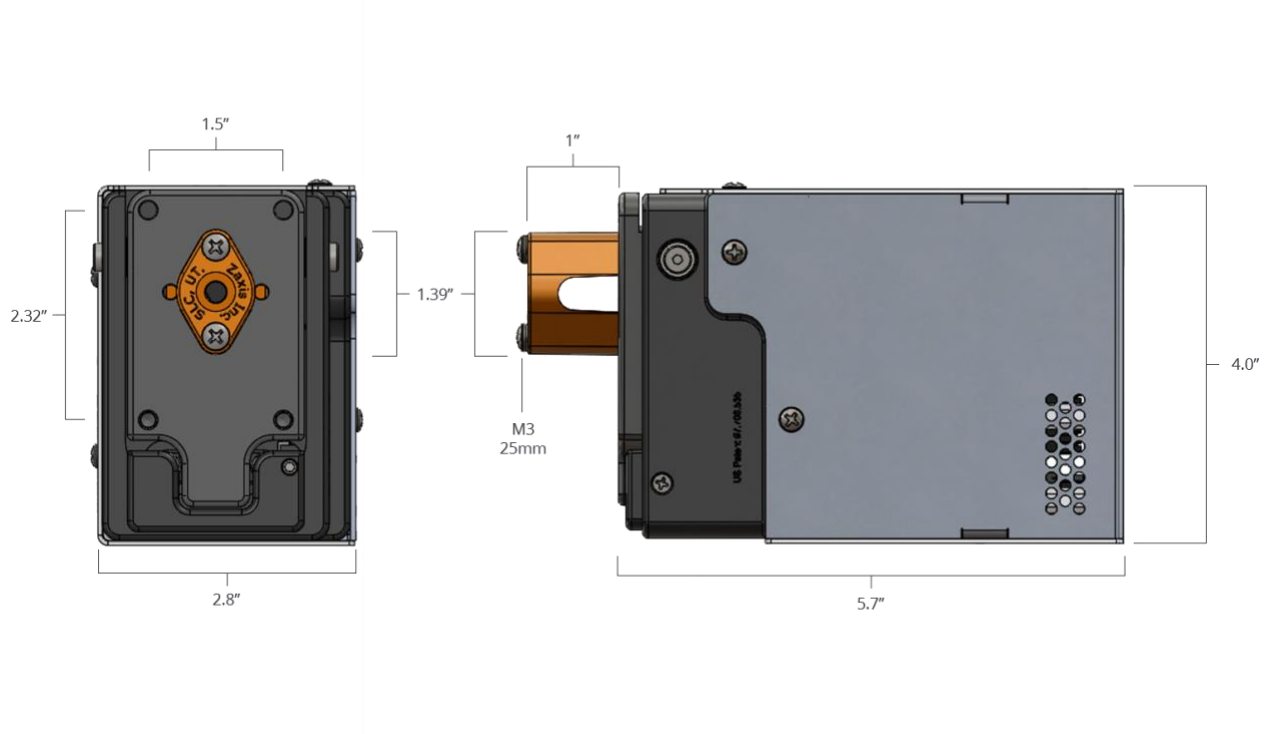

### 6.1.3 M-Series Pump Heads

The Zaxis eVmP M-Series Pump Heads are designed primarily for ultra-low volume metering and dispensing, providing high precision and accuracy. If you are looking to meter under 100 mL/min or dispense from 1 to 100  $\mu\text{L}$ , then the M-Series are ideal. The M-Series is constructed in two basic models, utilizing 316SS or PVDF (Kynar®) for the pump body, and standard with low flow, low dead volume  $\frac{1}{4}$  -28 female ports. **Select the piston size closest to your maximum volume for the best accuracy and precision.**

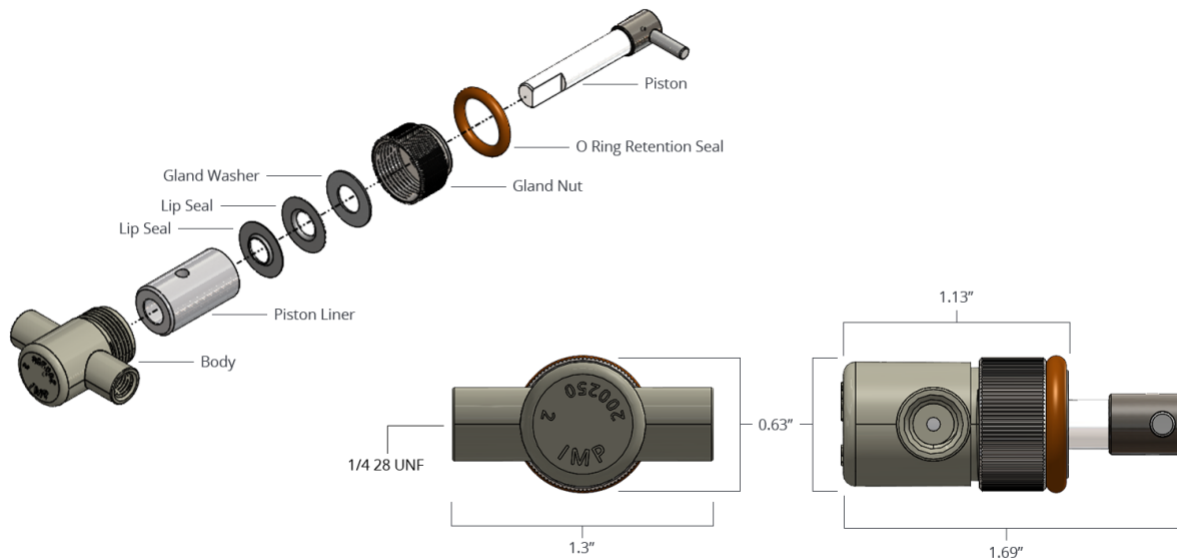

## 6.2 V-Series

### 6.2.1 V-Series Specifications

<b>Dimensions</b>	2.8" wide, 4" high, 6.5" deep	The V-Series is the original eVmP Smart Pump, designed for a wide range of applications, including neat chemistry, pastes, gels, or creams. These dimensions reflect the VS drive without an attached pump head.
<b>Weight</b>	7lbs (with pump head)	
<b>System Power</b>	24/36 VDC 2 Amps	Universal power requirements allowing us to ship testers all over the world.
<b>Pressure Range</b>	Up to 100 PSIG	
<b>RPM</b>	1000	
<b>Dispense &amp; Flow Range</b>	Head Size: V1	Up to 0.32mL/rev or 320mL/min
	Head Size: V2	Up to 0.72mL/rev or 720mL/min
	Head Size: V3	Up to 1.28mL/rev or 1280mL/min
<b>Media Compatibility</b>	Most acids and bases, water-like to slurry, monomers and some polymers	Ideal for food, pharma, and bio processes. Custom pump head materials are available.
<b>Wetted Path Options</b>	Ceramic (Medical grade alumina-oxide), 316SS, 303/304SS, PVDF, PEEK, Customization Available	Custom pump head materials are available.
<b>Operational Temps</b>	-20°C – 70°C, non-condensing	
<b>Operational Types</b>	Continuous Metering, Single/Multiple Dispense, Flow Direction, & Suck Back	The eVmP Smart Pump has been developed with versatility in mind. Our goal is to help you dispense what you want how you want.

<b>Stored Programs</b>	Up to 50	Run multiple parameters through a single pump.
<b>Interface</b>	EtherNet/IP, Ethernet TCP/IP, RS485, Digital I/O, 1/2 or Full Duplex	Multiple communication options specific to your application. See Section 3 on Communication
<b>Accuracy &amp; Repeatability</b>	1% +/- Full Scale, 0.5 CV	High accuracy and repeatability

## 6.2.2 V-Series Pump Drives

The eVmP V is our stepper-driven motor drive, designed for V series pump heads.

V Pumps are ideal for a very wide range of applications, including neat chemistry, and some slurries, pastes, gels, or creams. Flow rates are typically less than 1000 mL/min, and under 100 PSI, accepting SAN or CKC Pump Head materials of construction, making the V Series is one of our most popular pumps. Each V Drive is standard with RS485, 24 VDC Digital I/O, and Ethernet connections.

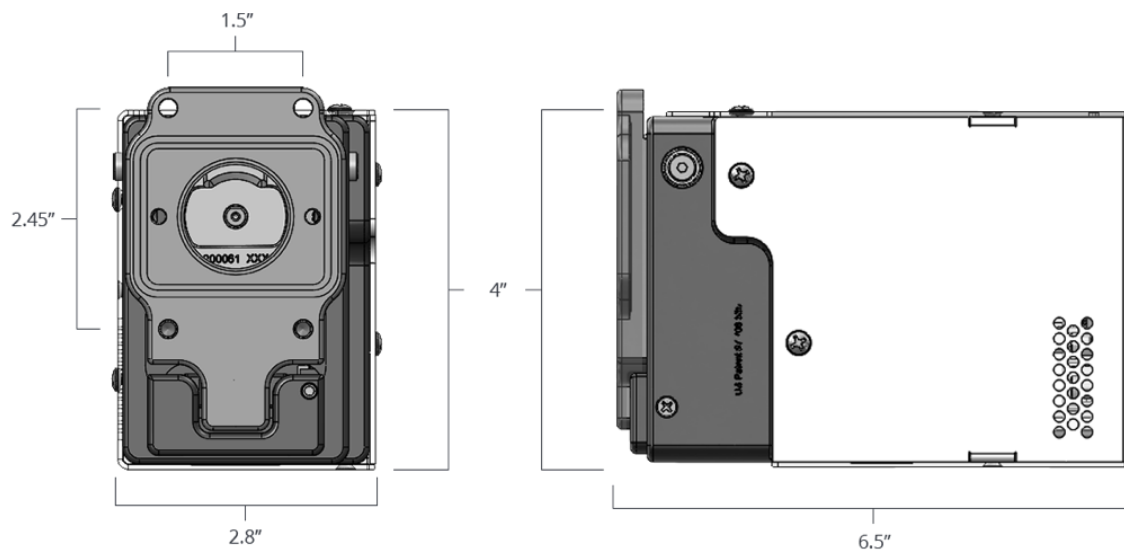

## 6.2.3 V-Series Pump Heads

The Zaxis eVmP V-Series Pump Heads are designed for the most demanding applications. The V-Series pump heads offer industry leading design for ease of disassembly, combined with rugged performance, high precision, and repeatability. If you are looking to meter up to 1.28L/min or dispense down to 25  $\mu\text{L}$ , then the V-Series are ideal. The V-Series is constructed with Male Gauge ISO Threads as standard, allowing for compression type fittings, which are available in a wide range of imperial and metric sizes. With 316SS and PTFE as the only wetted path materials, Food, Pharma, and Bio Processes are natural applications, however typical applications are wide ranging from Agriculture to Pharmaceutical. **Select the piston size closest to your maximum volume for the best accuracy and precision.**

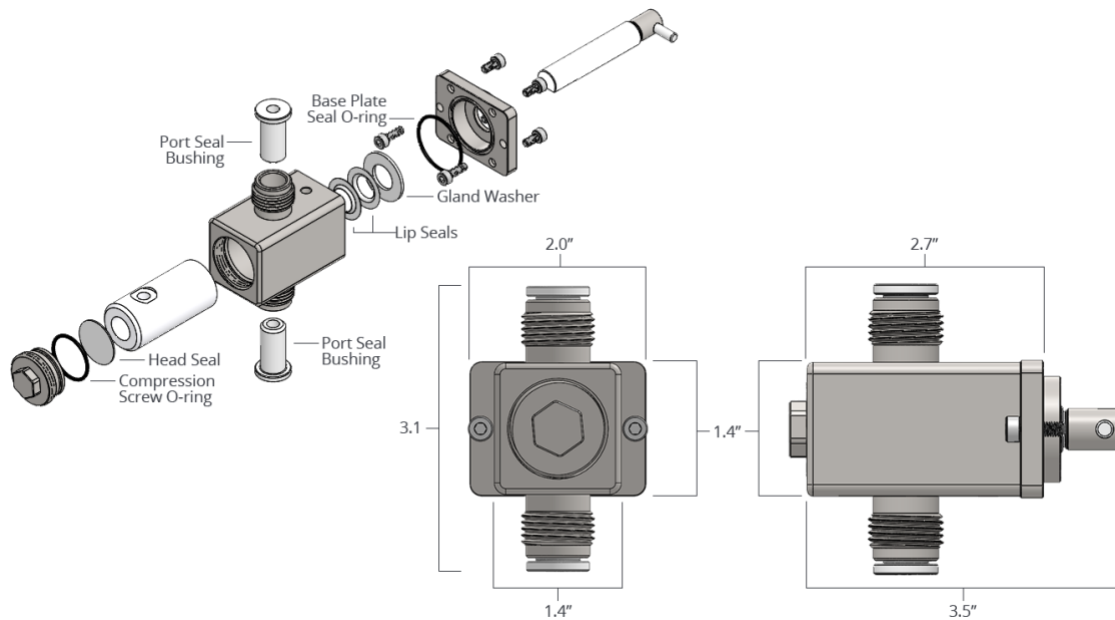

## 6.3 VS-Series

### 6.3.1 VS-Series Specifications

<b>Dimensions</b>	3.1" wide, 4.2" high, 7.4" deep	The VS-Series is the most dynamic eVmP Smart Pump, designed for demanding applications with higher flow rates. These dimensions reflect the VS drive without an attached pump head.
<b>Weight</b>	7.5lbs (with pump head)	
<b>System Power</b>	24/36 VDC 2 Amps	Universal power requirements allowing us to ship testers all over the world.
<b>Pressure Range</b>	Up to 200 PSIG	
<b>RPM</b>	1500	
<b>Dispense &amp; Flow Range</b>	Head Size: V1	Up to 0.32mL/rev or 450mL/min
	Head Size: V2	Up to 0.72mL/rev or 1080mL/min
	Head Size: V3	Up to 1.28mL/rev or 1920mL/min
<b>Media Compatibility</b>	Most acids and bases, water-like to slurry, monomers and some polymers	Ideal for food, pharma, and bio processes. Custom pump head materials are available.
<b>Wetted Path Options</b>	Ceramic (Medical grade alumina-oxide), 316SS, 303/304SS, PVDF, PEEK, Customization Available	Custom pump head materials are available.
<b>Operational Temps</b>	-20°C – 70°C, non-condensing	
<b>Operational Types</b>	Continuous Metering, Single/Multiple Dispense, Flow Direction, & Suck Back	The eVmP Smart Pump has been developed with versatility in mind. Our goal is to help you dispense what you want how you want.

<b>Stored Programs</b>	Up to 50	Run multiple parameters through a single pump.
<b>Interface</b>	EtherNet/IP, Ethernet TCP/IP, RS485, Digital I/O, 1/2 or Full Duplex	Multiple communication options specific to your application. See Section 3 on Communication
<b>Accuracy &amp; Repeatability</b>	1% +/- Full Scale, 0.5 CV	High accuracy and repeatability

### 6.3.2 VS-Series Pump Drives

The eVmP VS is our servo-driven motor drive, designed for V series pump heads. The Servo Drive is ideal for more demanding applications with higher flow rates, higher pressure, or higher viscosity applications. With nearly 4 times the torque, the VS series drive can handle flow rates near 2,000 mL/min and back pressure up to 200 psi, while accepting common V series pump heads, available in CKC or SAN materials of construction. Each VS Drive is standard with RS485, PLC I/O, and Ethernet connections.

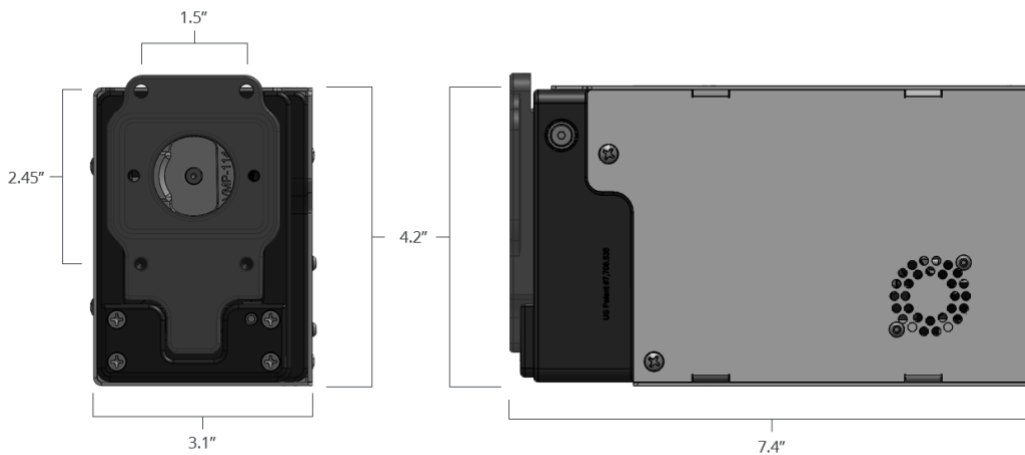

### 6.3.3 VS-Series Pump Heads

(see V-Series Pump Heads in Section 6.2.3)

## 6.4 VS6-Series

### 6.4.1 VS6-Series Specifications



<b>Dimensions</b>	3.1" wide, 4.2" high, 7.4" deep	The VS6-Series is the most robust eVmP Smart Pump, designed for demanding applications with higher volumes. These dimensions reflect the VS6 drive without an attached pump head.
<b>Weight</b>	13lbs (with pump head)	
<b>System Power</b>	24/36 VDC 4 Amps (75 VDC 5 Amp Power Optional)	Universal power requirements allowing us to ship testers all over the world.
<b>Pressure Range</b>	Up to 25 PSIG	
<b>RPM</b>	1500	
<b>Dispense &amp; Flow Range</b>	Head Size: 1"	Up to 6mL/rev or 9000mL/min
<b>Media Compatibility</b>	Most acids and bases, water-like to slurry, monomers and some polymers	Ideal for food, pharma, and bio processes. Custom pump head materialization is available.
<b>Wetted Path Options</b>	Ceramic (Medical grade alumina-oxide), 316SS, 303/304SS, PVDF, PEEK, Customization Available	Custom pump head materialization is available.
<b>Operational Temps</b>	-20°C – 70°C, non-condensing	
<b>Operational Types</b>	Continuous Metering, Single/Multiple Dispense, Flow Direction, & Suck Back	The eVmP Smart Pump has been developed with versatility in mind. Our goal is to help you dispense what you want how you want.
<b>Stored Programs</b>	Up to 50	Run multiple parameters through a single pump.
<b>Interface</b>	EtherNet/IP, Ethernet TCP/IP, RS485, Digital I/O, 1/2 or Full Duplex	Multiple communication options specific to your application. See Section 3 on Communication
<b>Accuracy &amp; Repeatability</b>	1% +/- Full Scale, 0.5 CV	High accuracy and repeatability

## 6.4.2 VS6-Series Pump Drives

The eVmP VS6 is our specialty, servo-driven motor drive, designed to accept to V6SAN Pump Head. Using one of the most powerful servo motors in the industry, and extra-large flow capacity, the VS6 can accomplish an amazing 6L/min and nearly 7 mL/stroke, at a maximum of 25 PSI. Each VS6 Drive is standard with RS485, PLC I/O, and Ethernet connections.

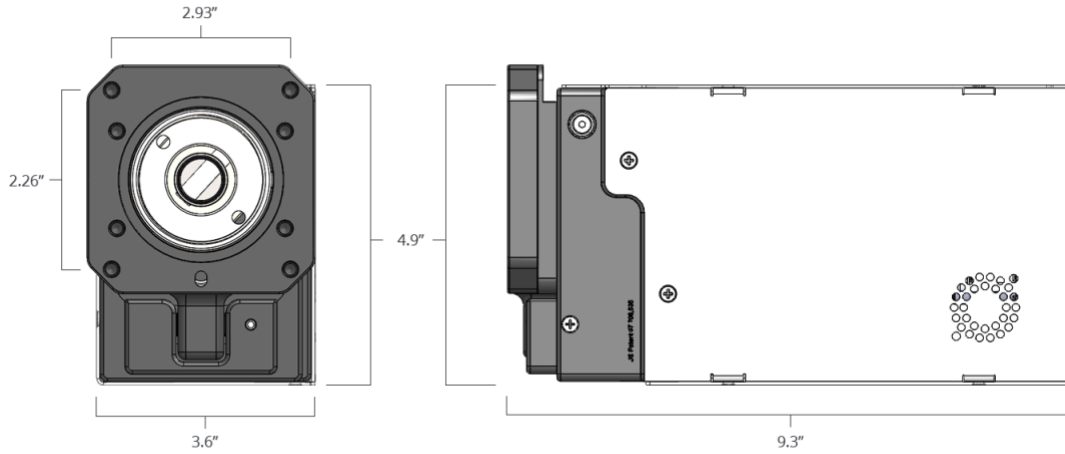

## 6.4.3 VS6-Series Pump Heads

The VS6-SAN Pump Head offers one of the largest fill volumes per stroke and metering rate in the precision metering industry, providing larger flow rates with a valve-less piston design. It features 316SS and PTFE wetted parts, as well as sanitary features such as tri clamp/sanitary fittings designed to meet FDA and 3A standards. Wash glands are included, as well as numerous fitting configurations to meet your application needs.

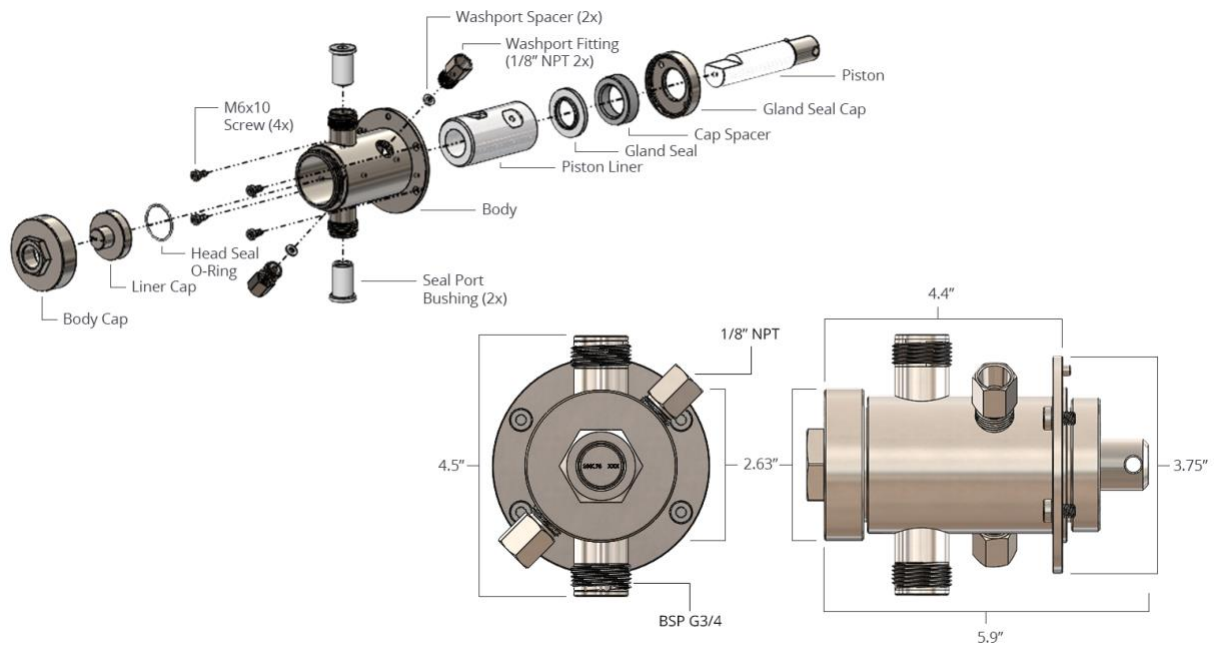

## 6.5 eVmP Dual Enclosure

### 6.5.1 Dual Enclosure Specifications

<b>Dimensions</b>	7.5" wide, 7.75" high, 12" deep.	The eVmP Dual Encloser can hold 2 compatible eVmP drives with heads.
<b>Compatibility</b>	V-Series	Customization available for M-Series or limited VS-Series.
<b>Weight</b>	26 lbs 3 oz (12 lbs 3 oz, Enclosure only)	Weight includes 2 V-Series drives with V-SAN heads.
<b>System Power</b>	120 VDC	Universal power requirements allowing us to ship testers all over the world.
<b>Pressure Range</b>	Variable	Depends on the selected pump drives.
<b>RPM</b>	Variable	Depends on the selected pump drives.
<b>Dispense &amp; Flow Range</b>	Variable	Depends on the selected pump drives.
<b>Media Compatibility</b>	Most acids and bases, water-like to slurry, monomers and some polymers	Ideal for food, pharma, and bio processes. Custom pump head materialization is available.
<b>Wetted Path Options</b>	Ceramic (Medical grade alumina-oxide), 316SS, 303/304SS, PVDF, PEEK, Customization Available	Custom pump head materialization is available.
<b>Operational Temps</b>	-20°C – 70°C, non-condensing	
<b>Operational Types</b>	Continuous Metering, Single/Multiple Dispense, Flow Direction, & Suck Back	The eVmP Smart Pump has been developed with versatility in mind. Our goal is to help you dispense what you want how you want.
<b>Stored Programs</b>	Up to 50	Run multiple parameters through a single pump.

<b>Interface</b>	Ethernet TCP/IP, RS485, Digital I/O, 1/2 or Full Duplex	Multiple communication options specific to your application. <b>See Section 3 on Communication</b>
<b>Accuracy &amp; Repeatability</b>	1% +/- Full Scale, 0.5 CV	High accuracy and repeatability

## 6.5.2 Dual Enclosure

The eVmP Dual Enclosure converts two eVmP V-Series pumps into the perfect dispensing station. The eVmP Dual Enclosure has an internal power supply and an IP45 rating, making the unit easy to move and suitable for research or manufacturing environments. The eVmP Dual Enclosure was also designed for easy communication for multiplexing. Each Enclosure has two 8 Pin RS485 ports for easy concatenation, simply daisy chain the Enclosures together and communicate with up to 16 Dual modules (32 pumps) with one TSi (Touchscreen Interface).

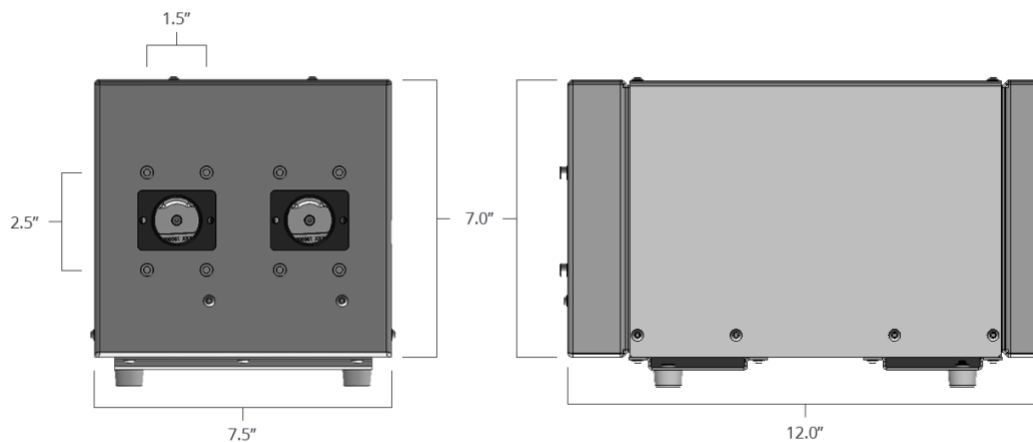

### 6.5.3 Dual Enclosure Compatible Pump Drives

The eVmP Dual Encloser was specifically designed to house two V-Series Smart Pumps. VS-Series Smart Pumps do fit in the enclosure, but due to the extended drive length required to accommodate the servo motors, the drive’s angle articulation is limited thereby limiting the dispense volume per shot. Customization of the faceplate is available to adapt the enclosure the Micro Series pump heads.

M-Series	V-Series	VS-Series	VS6-Series
Customization Available	Compatible	Limited Volume	Not Compatible

## 6.6 TSi

The 7" HD Touch Screen is designed to communicate, program, and teach up to 32 eVmP Pump Systems over RS485, and includes the communication cable.

<b>Dimensions</b>	7.5" wide, 5" high, 1" deep
<b>Weight</b>	12oz
<b>Power</b>	5 VDC ½ Duplex RS485 (usually powered by an eVmP drive)
<b>Interface</b>	8 Pin cable with male connector pins.



# One Year Limited Warranty

ZAXIS INC. products are manufactured to a high level of mechanical precision from materials that are resistant to attack by many corrosive chemicals. These products, however, may be self-destructive when used with non-compatible fluids or when located in physically hostile environments or when operated under non-specification voltage or pressure conditions.

ZAXIS INC., therefore, warrants only as follows:

Each metering head has been test operated with water to rated pressure prior to shipment from the factory. The qualifying performance of each metering head is recorded by serial number in a permanent record of the company. If at any time with-in the first year after any ZAXIS INC. product has been shipped to a customer (user), it fails to perform according to ZAXIS INC. literature, the product, with written explanation of the problem, may be returned, freight prepaid, to ZAXIS INC. for examination, repair or replacement at ZAXIS INC. expense (labor and material). All such returns must have prior ZAXIS INC. customer service authorization before returning. If, upon examination, ZAXIS INC. determines that abusive practices, non-compatible fluids or destructive environment of operation or a combination of these factors is responsible for improper performance of the product, all labor and materials costs involved shall be at the expense of the customer.

ZAXIS INC. is not liable for special, indirect or consequential damages that may result from use, failure or malfunction of the product, and any recovery against ZAXIS INC. may not be greater than the purchase price paid for the product.

No person is authorized to change the terms of this warranty.

## Terms and Conditions

### **Zaxis eVMP Pump Standards and Prices**

Zaxis products are quoted, sold, and certified to only comply with Zaxis specifications. Only Zaxis is authorized to modify product claims or specifications and are subject to change without notice. Zaxis prices are subject to change without notice. Quotations are valid for thirty (30) days, unless otherwise noted.

### **Payment Terms**

USA Sale: Zaxis standard payment terms are 50% down with PO, balance Net 30.

International Sales: Cash in Advance

Credit Cards Accepted: VISA/Master Card, DISCOVER, and American Express are accepted with a 3% processing fee.

All Bank charges related to wire transfers and ACH payments are the responsibility of the customer.

**Orders and Freight**

Zaxis orders are non-cancellable and will be shipped per Zaxis acknowledgement. Zaxis is not responsible for delays beyond our control; such as delays from vendors, labor disputes, or military/government action. All orders are delivered Ex Works, Zaxis Inc. factory, West Valley City, UT, at which time ownership and responsibility, including risk of loss shall pass to the customer.

All specialty packaging and insurance is the responsibility of the customer. Any claims for damaged items should be made with customer's delivering carrier, and or insurance company.

For any prepaid and add shipments, Zaxis will use UPS Ground, and customer must provide detailed insurance information.

**Returns for Credit**

Standard Zaxis pumps can be returned in most circumstances, and must be returned unopened, unused, and in original Zaxis packaging, within 30 days. All said returned items, must have Zaxis return authorization, (Case#). A restock fee of 10% of original invoice prices will be incurred.

# Technical Support

**Email**

service@zaxisinc.com

**Phone**

801-264-1000

**Address**

Zaxis  
2442 South 2570 West  
Salt Lake City, UT 84119

**Returns for Repair/Service**

All Zaxis pump drives and pump heads can be returned for repair/service, with written return authorization (case#). If returning a Zaxis pump head, please clean completely with water or isopropyl alcohol IPA > 70% and send copy of applicable MSDS for material last pumped.

For service please contact [pumpservice@zaxisinc.com](mailto:pumpservice@zaxisinc.com).