

ASM SERIES

Self-calibrating Smart-Switches

The patented design of the ASM Series Self-calibrating Smart-Switch is more accurate and easier to use than previous models. This Smart-Switch uses the actual load current to set the trip point. It takes just a couple of seconds of steady running conditions before the sensor locks onto the normal current level. The ASM Series is designed for overload, underload or operating window applications. Upon sensing an average operating current, the ASM self-learns and establishes a limit-alarm trip point based on 85–125% of normal current (overload/underload model only). Available in a solid- or split-core case.

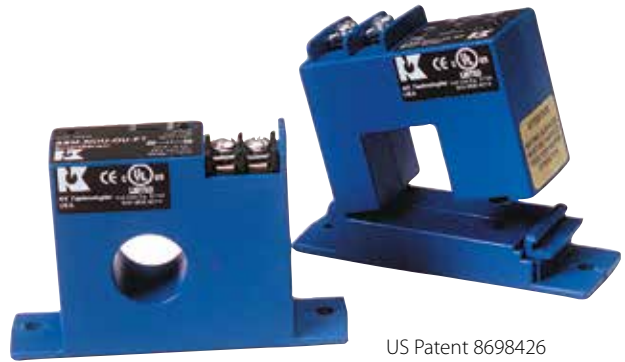

US Patent 8698426

Current Sensing Switch Applications

Conveyors (-OL Option)

- Detects jams and overloads.
- Interlocks multiple conveyor sections.

Electronic Proof of Flow (-UL Option)

- More reliable than electromechanical pressure or flow switches. No need for pipe or duct penetrations.

Pump Protection (-OU Option)

- Provides overload (jams) and underload (suction loss) indication.
- Interlocks multiple conveyor sections.

Current Sensing Switch Features

Self-powered and Self-calibrating

- Speeds startup, cuts installation costs.

Status Monitoring, Overload, and Operating Window Options

- Choose the operating style that matches your application.

Universal Output

- AC or DC compatibility with any automation system.

UL/cUL and CE Approved

- Accepted worldwide.

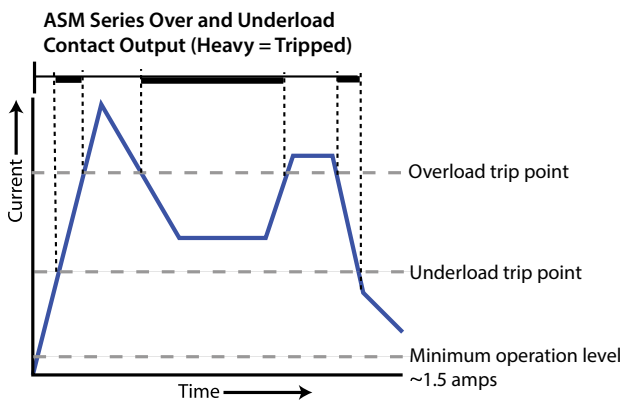

For additional Application Examples, go to www.nktechnologies.com/applications

OEMs

Test & Evaluation Units for OEMs

Free program expedites evaluation process. See page 3 for details.

Current Sensing Switch Dimensions

FT Case

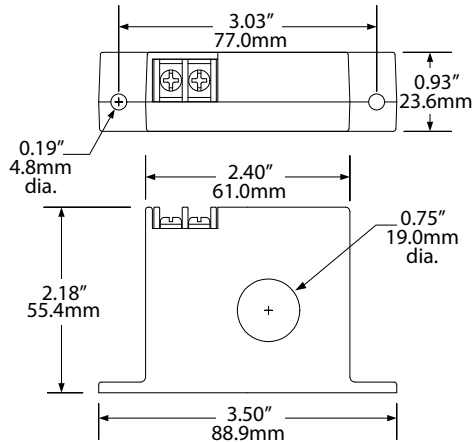

SP Case

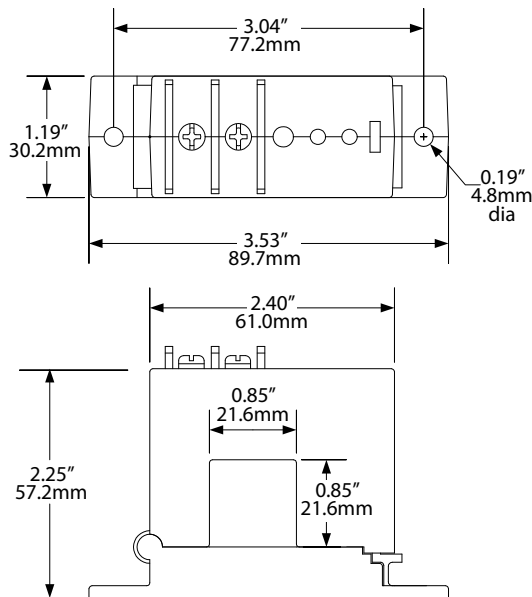

Current Sensing Switch Specifications



Power Supply	None, self-powered
Setpoint Range	• Solid-core: 1.5–150 A • Split-core: 2.8–150 A (self-calibrating)
Output Description	Isolated solid-state relay
Setpoint Calibration	Output changes with AC current between 85% and 125% of normal running current
Output Rating	• N.O. Version: 0.30 A @ 135 VAC or VDC • N.C. Version: 0.30 A @ 135 VAC/VDC • Not polarity sensitive
Off-state Leakage	<10 µA
Response Time	200 ms
Time Delay	None
Hysteresis	5%
Overload	500 A @ 6 sec., 1000 A @ 1 sec.
Isolation Voltage	UL listed to 1270 VAC, tested to 5 KV
Frequency Range	6–100 Hz
Case	UL94 V-0 Flammability Rated
Environmental	-4 to 122°F (-20 to 50°C) 0–95% RH, non-condensing
Listings	UL/cUL, CE

Current Sensing Switches

Current Sensing Switch Ordering Information

Sample Model Number: ASM-NOU-OL-SP
AC current sensing switch, normally open, self-calibrating overload operation in a split-core case. (DIN rail adapters are included)



(1) Output Rating

NOU	Normally Open
NCU	Normally Closed

(2) Operation

OL	Overload
UL	Underload
OU	Over/underload

(3) Case Style

FT	Solid-core, top terminals
SP	Split-core

