

APT SERIES

Power Transducers

APT Power Transducers measure three phases of current and voltage, and produce an industry standard analog signal proportional to the watts used. These monitors use current transformers to measure the amperes, and the line voltage connects directly to the transducer, up to 600 VAC. The APT Power Transducer can be configured to accept 5 A secondary current transformers or the safer ProteCT™ low voltage output sensors. Either type of current sensing will produce an accurate output signal to help you identify areas of excessive energy consumption and allow intervention to reduce demand.

Power Transducer Applications

Plant Energy Management

- Measure the power usage of a single piece of equipment, an area of a plant or the entire facility.

Conveyors

- Detects jams and overloads.
- Check that the belt is loaded properly by measuring the power consumption.

Pump Monitoring

- Detect dry run from clogged intake or discharge line.
- Monitor impeller cavitation and bearing wear.

Pump Jam & Suction Loss Protection

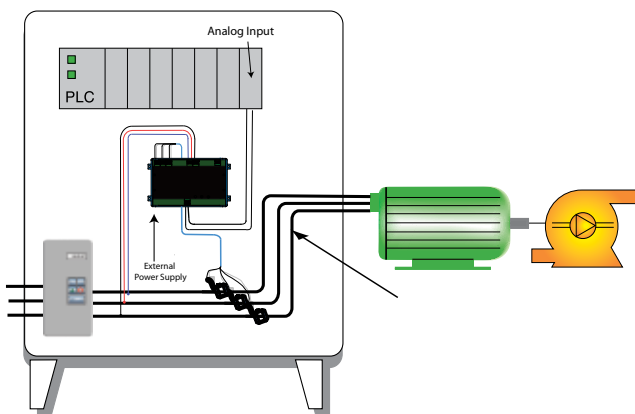

- For additional Application Examples, go to www.nktechnologies.com/applications



APT Power Monitor with Analog Output

Power Transducer Features

Industry Standard Analog Outputs

- Choose 4–20 mA, 0–5 or 0–10 VDC.
- Compatible with most automation systems.

Externally Powered

- Improves reliability when used in conditions where power interruptions and voltage sags are common.

Compact DIN Rail* or Panel Mounted

- Clearly labeled terminals provide quick installation.
- Low profile reduces cabinet depth requirements.

Finger Safe Terminals

- Safe and secure connectors.

UL/cUL Approved

- Accepted worldwide.

*For information on the DIN rail accessories kit, see page 144.

APT Output Values

APT Power Transducers produce full range output. When the current transformer is producing its maximum signal, the primary voltage is at the range maximum and power factor is at unity. As an example, using the APT-480-5 A-120-420 with 400:5 current transformers, the transducer will produce 20 mA when there is 400 A through the CT and the primary voltage is 480. If the transducer is used to monitor a three-phase circuit using three CTs, 20 mA represents 332,544 watts. The equation for three-phase wattage is voltage times amperage, times the square root of three (1.732) times power factor. If this transducer is used to monitor a three-phase load using two CTs, the transducer will produce 14.67 mA, or the output will represent 2/3 of the actual watts being used under the same conditions: 480 V primary voltage, 400 A through 400:5 CTs and unity power factor.



Power Transducer Dimensions

Case Front View

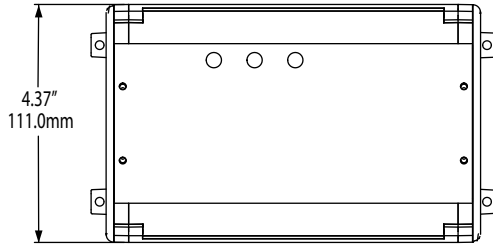

Case Top View

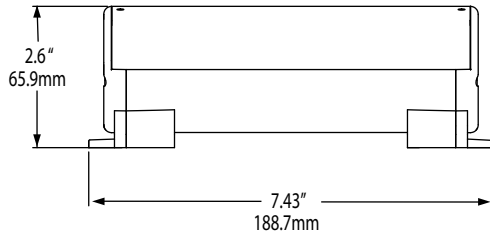

Case Side View

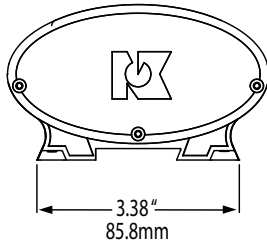

Note: Drawings are not to scale.

Power Transducer Connections

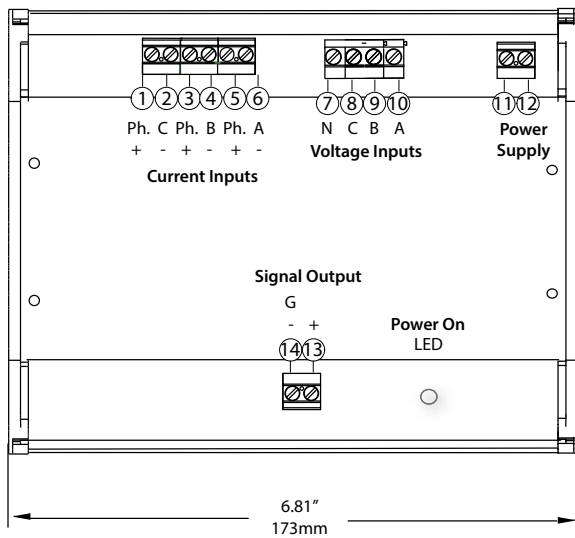

Power Transducer Specifications



Power Supply	• 24 VAC/DC (21–26 V) • 120 VAC (108–132 V) • 240 VAC (216–264 V)
Power Consumption	<2 VA
Primary Voltage Input	120, 240, 480 or 600 VAC
Output	• 4–20 mA current • 0–5 or 0–10 VDC
Accuracy	<0.5% FS
Response Time	120 ms
Isolation Voltage	Tested to 4 KV
Frequency Range	6–100 Hz
Case	UL94 V-0 Flammability Rated
Environmental	-4 to 122°F (-20 to 50°C) 0–95% RH, non-condensing
Listings	UL/cUL

Power Transducer Ordering Information

Sample Model Number: APT-480-MV-120-420

AC power transducer, 480 VAC input, ProteCT™ current inputs, 120 VAC powered, 4–20 mA output, DIN rail mounting.



(1) Primary Voltage

120	120 VAC
240	240 VAC
480	480 VAC
600	600 VAC

(2) Current Input Type

MV	ProteCT™ current transformers, 333 mVAC secondary
5 A	5 A secondary current transformers

(3) Power Supply

24U	24 VAC/DC
120	120 VAC
240	240 VAC

(4) Output Type

420	4–20 mA proportional to wattage (see calculation example under APT Output Values)
005	0–5 VDC
010	0–10 VDC



Test & Evaluation Units for OEMs

Free program expedites evaluation process. See page 3 for details.

