

PPC4™
Pressure Controller/Calibrator
Operation and Maintenance Manual

⚠ Warning

- **High pressure liquids and gases are potentially hazardous. Energy stored in these liquids and gases can be released unexpectedly and with extreme force. High pressure systems should be assembled and operated only by personnel who have been instructed in proper safety practices.**
- **The PPC4 must be properly earthed. Only use a supply outlet that has a protective earth contact. If there is any doubt as to the effectiveness of the supply outlet earth, do not connect the PPC4.**
- **This instrument is not to be operated in any other manner than that specified by the manufacturer.**

© 2009 **DH Instruments, a Fluke Company** All rights reserved.

Information in this document is subject to change without notice. No part of this document may be reproduced or transmitted in any form or by any means, electronic or mechanical, for any purpose, without the express written permission of **DH Instruments, a Fluke Company** 4765 East Beautiful Lane, Phoenix AZ 85044-5318, USA.

DH Instruments makes sincere efforts to ensure accuracy and quality of its' published materials; however, no warranty, expressed or implied, is provided. **DH Instruments** disclaims any responsibility or liability for any direct or indirect damages resulting from the use of the information in this manual or products described in it. Mention of any product or brand does not constitute an endorsement by **DH Instruments** of that product or brand. This manual was originally composed in English and was subsequently translated into other languages. The fidelity of the translation cannot be guaranteed. In case of conflict between the English version and other language versions, the English version predominates.

Products described in this manual are manufactured under international patents and one or more of the following U.S. patents: 5,142,483; 5,257,640; 5,331,838; 5,445,035. Other U.S. and international patents pending.

AutoRange, AutoZ, **DH Instruments, DH, DHI, COMPASS, PPC, PPC4, Q-RPT, RPM, RPM4, SDS and SPLT** are trademarks, registered and otherwise, of **DH Instruments, a Fluke Company**.

Document No. 3306047 Rev 003
091211
Printed in the USA.

Table Of Contents



Table Of Contents	III
Tables	IX
Figures	X
About This Manual	XI
1. Introduction	1
1.1 Product Overview	1
1.2 Specifications	1
1.2.1 General Specifications	1
1.2.2 Pressure Measurement Specifications	2
1.2.2.1 Quartz Reference Pressure Transducer (Q-RPT)	2
1.2.2.2 Utility Sensor	4
1.2.2.3 On-Board Barometer	4
1.2.3 Pressure Control Specifications	4
2. Installation	5
2.1 Unpacking And Inspection	5
2.1.1 Removing From Packaging	5
2.1.2 Inspecting Contents	5
2.2 Site Requirements	6
2.3 Setup	6
2.3.1 Preparing For Operation	6
2.3.2 Front And Rear Panels	7
2.3.2.1 Front Panel	7
2.3.2.2 Rear Panel	8
2.3.3 Power Connection	8
2.3.4 Connecting To A Pressure Supply (Supply Port)	8
2.3.5 Connecting A Vacuum Pump (Exhaust Port)	9
2.3.6 Connecting External Q-RPTS In RPM4 Reference Pressure Monitor	9
2.3.7 Connecting To The Device Under Test (Test(+) And Test(-) Ports)	10
2.3.7.1 Installing a Self Purging Liquid Trap (SPLT)	12
2.3.7.2 Installing a Dual Volume Unit (DVU), G15K and BG15K Q-RPTS	12
2.3.8 The ATM Port	12
2.3.9 Check/Set Security Level	12
2.3.10 Turn Off Absolute And Negative Gauge Mode (AXXX RPT)	13
2.4 Power-Up And Verification	13
2.4.1 Switch Power On	13
2.4.2 Check Pressure Measurement Operation	13
2.4.2.1 Checking Absolute Mode Pressure Measurement	13
2.4.2.2 Checking Gauge Mode Pressure Measurement	14
2.4.3 Leak Test	15
2.4.4 Purge	15
2.4.5 Check Pressure Control Operation	15
2.4.5.1 Basic Interface	15
2.4.5.2 Advanced Interface	15
2.5 Short Term Storage	16
3. Operating Principles	17
3.1 User Interfaces	17
3.2 General Operating Principles	17

3.2.1	Direct Pressure Control	17
3.2.2	Automated Pressure Control.....	17
3.2.2.1	Dynamic Control	18
3.2.2.2	Static Control	19
3.2.3	Pressure Ready/Not Ready.....	19
3.2.4	Gauge and Negative Gauge Modes with an Axxx (Absolute) Q-RPT, Dynamic Compensation for Atmospheric Pressure	21
3.2.5	Multiple Internal and External Q-RPTs	22
3.2.6	Multiple Ranges (Q-RPTs, AutoRange and Infinite Ranging).....	23
3.2.7	Operation with a PG7000 Piston Gauge	24
3.2.8	AutoRange	24
3.2.9	Range.....	27
3.2.10	Unit.....	27
3.2.11	Measurement Mode	28
3.2.12	Set Pressure Automatically	29
3.2.13	Control	30
3.2.14	Vent.....	31
3.2.15	AutoTest	31
3.2.16	Head	32
3.2.17	Purge	33
3.2.18	Leak Test	35
3.2.19	Resolution	35
3.2.20	Jog	36
3.2.21	Pressure Limits	36
3.2.21.1	Over Pressure Function	37
3.2.22	AutoZero (AutoZ).....	38
3.2.22.1	Edit AutoZ.....	41
3.2.22.2	Run AutoZ.....	41
3.2.23	Drivers	42
3.2.24	Remote.....	42
3.2.25	Reset.....	43
3.2.25.1	Settings.....	43
3.2.25.2	Units	44
3.2.25.3	AutoTest	44
3.2.25.4	Calibration.....	44
3.2.25.5	All.....	45
3.2.26	Preferences	46
3.2.26.1	Screen Saver	46
3.2.26.2	Sounds.....	46
3.2.26.3	Time.....	47
3.2.26.4	Language.....	47
3.2.26.5	Security	47
3.2.27	Internal Functions.....	50
3.2.27.1	Identification.....	50
3.2.27.2	Control Reference	50
3.2.27.3	Barometer	51
3.2.27.4	Purge	52
3.2.27.5	Log.....	52
3.2.27.6	TEST (-) Vent.....	52
3.2.28	Calibration	53
3.2.29	Measurement Uncertainty.....	53
3.2.29.1	Product Uncertainty.....	54
3.2.29.2	Head	55
3.2.29.3	Zero Stability	55
3.2.29.4	Control Uncertainty	55
3.2.29.5	Combining uncertainties.....	56
3.2.29.6	Delivered Pressure Uncertainty.....	57
3.2.29.7	Using Values Other Than Default.....	57

4. Basic User Interface 59

4.1	Main Run Screen	59
4.2	Keypad and Controls	61
4.2.1	Set Pressure Automatically	61
4.2.1.1	Interrupting Automated Pressure Control	62
4.2.1.2	Automated Pressure Commands for Zero Pressure.....	62
4.2.2	Vent.....	63
4.3	Basic Interface menus	63
4.3.1	Main Menu Tree.....	63
4.4	Menu Tree Operation	64

4.4.1	<Setup>, <Range>	64
4.4.1.1	Saving An AutoRanged Range	64
4.4.1.2	Deleting AutoRange Ranges	65
4.4.2	<Setup>, <Res> (Resolution)	65
4.4.3	<Setup>, <Jog>	65
4.4.4	<Setup>, (Upper Limit)	66
4.4.4.1	Over Pressure Function	66
4.4.5	<Setup>, <Control>	67
4.4.5.1	<Limits> (Custom Control Parameters)	67
4.4.5.2	Turning-Off Custom Control Parameters	68
4.4.6	<Setup>, <Drv> (Drivers)	68
4.5	<Spec> (Special)	68
4.5.1	<Spec>, <AutoZ>	69
4.5.1.1	Edit AutoZ	70
4.5.1.2	Run AutoZ	70
4.5.2	<Spec>, <Remote>	71
4.5.2.1	<COM1> and <COM2>	71
4.5.2.2	<IEEE-488>	71
4.5.2.3	<Format>	71
4.5.2.4	<RS232test>	72
4.5.2.5	<Ethernet>	72
4.5.3	<Spec>, <Head>	73
4.5.4	<Spec>, <Reset>	73
4.5.4.1	<Set>	73
4.5.4.2	<Units>	74
4.5.4.3	<Cal>	74
4.5.4.4	<All>	74
4.5.5	<Spec>, <Prefs>	74
4.5.5.1	<ScrSvr>	75
4.5.5.2	<Sound>	75
4.5.5.3	<Time>	75
4.5.5.4	<ID>	75
4.5.5.5	<Level> (Security)	76
4.5.6	<Spec>, <Punit>	77
4.5.7	<Spec>, <Internal>	78
4.5.7.1	<Config>	78
4.5.7.2	<Control Ref>	78
4.5.7.3	<Baro>	79
4.5.7.4	<Purge>	79
4.5.7.5	<Lo Vnt>	80
4.5.8	<Spec>, <Cal>	80
4.5.9	<Spec>, <Log>	81
4.5.10	<ARange>	81
4.5.11	<Leak>	82
4.5.12	<RPT>	83
4.5.13	<Unit>	84
4.5.14	<Range>	84
4.5.15	<Mode>	85
4.5.16	<Head>	85
4.5.17	<Purge>	86

5. Advanced User Interface 87

5.1	Main Run Screen	87
5.2	Other Screens	89
5.3	Keypad Layout and Protocol	90
5.4	Conventions for the Advanced Interface	90
5.4.1	Navigation Controls and Keypad	90
5.4.2	Navigating Advanced Interface Menus	91
5.5	Pressure Control	93
5.5.1	Set Pressure Automatically	93
5.5.1.1	Interrupting Automated Pressure Control	94
5.5.1.2	Automated Pressure Commands for Zero Pressure	94
5.5.2	Manual Pressure Control	94
5.5.3	Vent	95
5.6	Advanced Interface Menus	95
5.6.1	Shortcuts	95
5.6.2	Menu Structure	95

5.7	Menu operation.....	96
5.7.1	AutoRange.....	96
5.7.2	AutoTest.....	99
5.7.2.1	Exercise.....	99
5.7.2.2	Quick Test.....	100
5.7.2.3	Advanced Test.....	102
5.7.3	Pressure.....	106
5.7.3.1	Purge.....	106
5.7.3.2	Leak Test.....	107
5.7.4	Drivers.....	108
5.7.5	System.....	108
5.7.5.1	Run AutoZ.....	108
5.7.5.2	Control Configuration.....	109
5.7.5.3	Reset.....	110
5.7.6	Pressure.....	111
5.7.6.1	Pressure Unit.....	111
5.7.6.2	Measurement Mode.....	113
5.7.6.3	Head.....	113
5.7.6.4	Resolution.....	114
5.7.7	Preferences.....	115
5.7.7.1	Screen Saver.....	115
5.7.7.2	Sounds.....	115
5.7.7.3	Time.....	116
5.7.7.4	Language.....	116
5.7.7.5	Security.....	117
5.7.7.6	Edit Security Password.....	117
5.7.8	Control.....	118
5.7.8.1	Pressure Limits.....	118
5.7.8.2	Pressure Control.....	119
5.7.8.3	Jog Step.....	120
5.7.9	Remote.....	120
5.7.9.1	COM1 and COM2.....	121
5.7.9.2	Command Format.....	121
5.7.9.3	IEEE-488.....	121
5.7.9.4	Ethernet.....	121
5.7.10	Calibration.....	122
5.7.11	Uncertainty.....	122
5.7.12	Internal.....	122
5.7.12.1	ID.....	122
5.7.12.2	Control Reference.....	123
5.7.12.3	Purge.....	123
5.7.12.4	Event log.....	123
5.7.12.5	TEST (-) Vent.....	124

6. Remote Operation 125

6.1	Overview.....	125
6.2	PPC4 Cockpit.....	125
6.2.1	Overview.....	125
6.2.2	Installation.....	125
6.2.2.1	USB Driver Installation.....	125
6.2.3	Running the Cockpit.....	128
6.2.3.1	USB Interface.....	129
6.2.3.2	RS232 Interface.....	129
6.2.3.3	Keyboard Shortcuts.....	130
6.3	Remote Interfacing.....	131
6.3.1	RS232 Interface.....	131
6.3.1.1	COM1.....	131
6.3.1.2	COM2.....	131
6.3.1.3	RS232 Command Testing.....	132
6.3.2	IEEE-488.....	135
6.3.2.1	IEEE-488 Remote Command testing.....	135
6.3.3	USB.....	136
6.3.4	Ethernet (Optional).....	136
6.4	Programming Formats.....	137
6.4.1	Classic Program Message Format.....	137
6.4.2	Enhanced Program Message Format.....	137
6.4.2.1	Using Command Type Commands.....	138
6.4.2.2	Using Query Type Commands.....	139
6.5	Commands.....	139

6.5.1	Programming Messages.....	139
6.5.2	Error Messages.....	141
6.5.3	Program Message Description Overview.....	142
6.5.4	Program Message Descriptions.....	143
6.6	Status Reporting System.....	175
6.6.1	Error Queue.....	175
6.6.2	Status Byte Register.....	175
6.6.3	Standard Event Register.....	177
6.6.4	Ready Status Register.....	177
6.7	IEEE STD. 488.2 Common And Status Program Messages.....	178
6.7.1	Program Message Descriptions.....	178
7.	Maintenance, Adjustments and Calibration	183
7.1	Overview.....	183
7.2	Calibration of Quartz Reference Pressure Transducers (Q-RPTs).....	183
7.2.1	Principle.....	183
7.2.1.1	PA and PM Coefficients.....	184
7.2.1.2	As Received and As Left Data.....	185
7.2.2	Equipment Required.....	185
7.2.3	Set-up and Preparation.....	186
7.2.4	Recommended Calibration Point Sequence.....	186
7.2.4.1	Standard and Full Scale Standard Class Q-RPTs.....	187
7.2.4.2	Premium Class Q-RPTs.....	188
7.2.5	Turning Off Absolute and Negative Gauge Measurement Modes for Axxx (Absolute) Q-RPTs.....	190
7.2.5.1	Basic Interface.....	190
7.2.5.2	Advanced Interface.....	190
7.2.6	Q-RPT Calibration Using CalTool for RPTs Software.....	191
7.2.7	Editing and Viewing Q-RPT Calibration Information.....	191
7.2.7.1	Basic Interface.....	192
7.2.7.2	Advanced Interface.....	192
7.2.7.3	Q- RPT Uncertainty.....	193
7.2.8	Q-RPT Calibration/Adjustment without CalTool for RPTs Software.....	194
7.2.8.1	Basic Interface Operation.....	194
7.2.8.2	Advanced Interface Operation.....	195
7.3	Adjustment of an On-board Barometer.....	196
7.3.1	Basic Interface.....	196
7.3.2	Advanced Interface.....	196
7.4	Adjustment of Utility Sensor.....	197
7.5	Pneumatic Control Module Configuration.....	197
7.5.1	Basic Interface Operation.....	198
7.5.2	Advanced Interface Operation.....	199
7.6	Reloading Embedded Software into Flash Memory.....	199
7.7	Removing the PPC4 Cover.....	200
7.8	Overhaul.....	200
7.9	Subassembly Description and Location.....	201
7.9.1	Power Supply Module.....	202
7.9.2	PowerPC Board.....	202
7.9.3	Q-RPT MODULE.....	202
7.9.3.1	Hi Q-RPT or Utility Sensor.....	202
7.9.3.2	Lo Q-RPT.....	202
7.9.4	On-board Barometer.....	202
7.9.5	Vacuum Sensor.....	203
7.9.6	Pressure Control Module.....	203
7.9.7	Display.....	203
7.9.8	Driver Board.....	203
7.10	Pneumatic Schematics.....	204
7.10.1	Pressure Control Module.....	204
7.10.2	Q-RPT Module Configurations.....	205
8.	Troubleshooting	207
9.	Appendix.....	211

9.1	Drivers	211
9.2	Unit Conversion.....	212
9.2.1	Pressure	212
10.	Warranty	213
10.1	Overview	213
11.	Glossary	215

Tables



Table 1. Reference Pressure Transducer (Q-RPT) Designations and Ranges	2
Table 2. PPC4 Packing List.....	5
Table 3. Position Designators of Q-RPTs in a PPC4 System	23
Table 4. Settings and What They Are Specific To (Range, Measurement Mode, Q-RPT, System)	24
Table 5. Settings Made by AutoRange.....	25
Table 6. Default Pressure Control Parameters	31
Table 7. AutoZ ON and OFF	40
Table 8. Reset Settings	43
Table 9. Reset Calibration.....	45
Table 10. Reset All.....	45
Table 11. Security Levels, Advanced Interface	49
Table 12. Security Levels, Basic Interface	49
Table 13. Default Values for PPC4 Uncertainty Components.....	56
Table 14. Unit Function - Available Units of Measure	77
Table 15. Main Run Screen Fields and Buttons.....	88
Table 16. Lower Level Screen Displays and Selectable Fields.....	89
Table 17. Advanced Interface Menu Structure.....	96
Table 18. PPC4 Cockpit Keyboard Shortcuts	130
Table 19. COM1 Pin Designations and Connections	131
Table 20. COM2 DB-9F Pin Designations.....	132
Table 21. Program Message List	139
Table 22. Error #s and Descriptions.....	141
Table 23. 8 Bit Status Byte Register	175
Table 24. 8 Bit Standard Event Register	177
Table 25. 8 Bit Ready Status Register	177
Table 26. Program Message List	178
Table 27. Calibration Point Sequence, Standard Class, Axxx and Gxxx Q-RPTs.....	187
Table 28. Calibration Point Sequence, Standard Class, BGxxx Q-RPTs	188
Table 29. Calibration Point Sequence, Standard Class, BA100K Q-RPT	188
Table 30. Calibration Point Sequence, Premium Class, Axxx and Gxxx Q-RPTs.....	189
Table 31. Calibration Point Sequence, Premium Class, BGxxx Q-RPTs	189
Table 32. Troubleshooting Guide.....	207
Table 33. External Drivers Current Output.....	211
Table 34. External Drivers Pin Outs.....	211
Table 35. Pressure Unit of Measure Conversion Coefficients	212
Table 36. DHI Authorized Service Providers.....	213



Figures

Figure 1. PPC4 advanced interface front panel 7

Figure 2. PPC4 basic interface front panel 7

Figure 3. Rear panel with optional connectors 8

Figure 4. Dynamic Pressure Control Operation 18

Figure 5. Static Pressure Control Operation 19

Figure 6. *Ready/Not Ready* in Dynamic Pressure Control Mode 20

Figure 7. *Ready/Not Ready* in Static Control Mode 21

Figure 8. Product Uncertainty Illustration 54

Figure 9. Main Run Screen Display Fields 60

Figure 10. Basic PPC4 Keypad Layout 61

Figure 11. Main Run Screen Display and Selectable Fields (see Table 15) 87

Figure 12. Advanced Interface Lower Level Screen Example (see Table 16) 89

Figure 13. Keypad layout..... 90

Figure 14. AutoRange Bar..... 98

Figure 15. Windows Hardware Wizard 126

Figure 16. Driver Location 126

Figure 17. Browse for Driver Location..... 127

Figure 18. Driver Warning Message 127

Figure 19. Driver Setup Complete 128

Figure 20. PPC4 Cockpit Main Display 128

Figure 21. PPC4 Cockpit Communication Selection..... 129

Figure 22. PPC4 Cockpit Communication Selection..... 129

Figure 23. PPC4 Cockpit RS232 Settings..... 129

Figure 24. PPC4 Cockpit Pressure Control Buttons 130

Figure 25. Windows selection of Hyperterminal..... 132

Figure 26. Hyperterminal Initial Display..... 132

Figure 27. Hyperterminal ASCII Setup 134

Figure 28. Status Register Schematic..... 176

Figure 29. Removing Back Cover 200

Figure 30. Internal View 201

Figure 31. Pressure Control Module Schematic 204

Figure 32. Q-RPT Module Schematics for Various Configurations..... 206

Figure 33. Drivers Connector Schematic 211

About This Manual



This manual is intended to provide the user with the basic information necessary to operate a PPC4 pressure controller/calibrator. It also includes a great deal of additional information provided to allow you to optimize PPC4 use and take full advantage of its many features and functions.

Before using the manual, take a moment to familiarize yourself with the Table of Contents structure: Sections 1, 2 and 3 should be read by all first time PPC4 users. Section 4 is important for those needing to communicate in local mode with the Basic user interface. Section 5 is important for those using the Advanced user interface. Section 6 is for remote operation from an external computer. Section 7 provides maintenance and calibration information. Section 8 is a quick troubleshooting guide. Use it to troubleshoot unexpected PPC4 behavior based on the symptom of that behavior. Certain words and expressions have specific meaning as they pertain to PPC4. The Glossary, Section 11 is useful as a quick reference for exact definition of specific words and expressions as they are used in the manual.

Note

For those who “don’t read manuals”, go directly to Section 2.3 to set up your PPC4 and then go to Section 2.4 for power-up and verification. This will get you up and running quickly with a minimal risk of causing damage to yourself or your new PPC4. THEN...when you have questions or start to wonder about all the great features you might be missing, get into the manual!

Manual Conventions

Note

- This manual is written for both the basic PPC4 and the PPC4-ui. Throughout the manual the local interface for the PPC4-ui, which has a large color graphics display and is typically used in bench top applications, is referred to as the *Advanced user interface* or *Advanced Interface*. In turn the limited function local interface for the basic PPC4, which is typically controlled by a remote computer, is referred to as the *Basic user interface* or *Basic Interface*.
- When the term “PPC4” is used alone, it typically refers to both basic PPC4 and PPC4-ui collectively since the only difference between the two is the local user interface.
- Detailed description of menu structure, key press sequences and conventions for the Advanced user interface are found in Section 5.
- Detailed description of menu structure, key press sequences and conventions for the basic user interface are found in Section 4.
- For dedicated front panel keys, such as **ESC**, **VENT**, **SET P**, and **ENTER**, any time a key is shown in the manual, it should be interpreted to mean “press this key”. For example: **ESC** to return to the Main Run Screen means “Press the **ESC** button to return to the Main Run Screen”.
- For users of the electronic (pdf) version of this manual, there is extensive use of hot links for the table of contents, figure references, table references and all section references found throughout. Simply click on a reference to follow the live link.

⚠ Caution

“Caution” is used in throughout the manual to identify conditions or actions that could cause harm to the PPC4 or to the devices that are connected to the PPC4.

⚠ Warning

“Warning” is used in throughout the manual to identify actions that could pose a hazard to the user of the PPC4.

Note

“Note” is used throughout the manual to identify operating and applications advice and additional explanations.



1. Introduction

1.1 Product Overview

PPC4 is a stand-alone pressure controller intended for precision setting and control of gas pressure into a closed volume as is commonly needed for the calibration and testing of pressure measuring instruments. It has been designed to provide very high performance combined with maximum versatility and ease of use.

PPC4 can be equipped with a low cost utility sensor for pressure monitoring or one or two Quartz Reference Pressure Transducers (Q-RPTs) to allow it to set and measure pressure with very low measurement uncertainty. Up to two external Q-RPTs in an external Reference Pressure Monitor (RPM4) can also be integrated into a PPC4 system. In some cases, a barometer is included.

Pressure control is achieved by a patented pneumatic module based on digitally controlled solenoid valves and differential pressure regulators.

PPC4 is controlled locally by the operator using a front panel display, keypad and function keys or remotely by a computer using ASCII character command strings over RS232, IEEE-488.2 or Ethernet.

PPC4 models are available to measure and control pressure in ranges from as low as - 3 to 3 kPa (0.4 psi) to as high as 0 to 14 MPa (0 to 2 000 psi) in absolute, gauge and compound gauge measurement modes.

1.2 Specifications

1.2.1 General Specifications

Power Requirements	100 to 240 VAC (-15%, +10%), 50-60 Hz, 70 VA max consumption
Operating Temperature Range	10 to 40 °C
Storage Temperature Range	-20 to 70 °C
Vibration	Meets MIL-PRF-28800F Class 3
Weight	16.6 kg (36.5 lb)
Dimensions	PPC4: 19 cm H x 35 cm W x 41 cm D (7.5 in. x 13.8 in. x 16.1 in.) PPC4-ui: 19 cm H x 35 cm W x 45 cm D (7.5 in. x 13.8 in. x 17.7 in.)
Ventilation	To prevent product overheating, provide proper ventilation. Allow 10 cm (4 in.) clearance from rear panel cooling fan.
Microprocessors	Motorola 68302, 16 MHz
Remote communication interfaces	RS232 (COM1, COM2), USB (front panel) Optional: IEEE-488.2, Ethernet and rear panel USB
Fuses	1 A, 250 VAC fuse, 5 x 20 mm, time lag type fuse. Internal power supply fuse not replaceable by operator: 2A, 250 V (UV 440-2 power supply), 3.15A, 250 V (NFS40-7612 power supply)
Pressure Ranges	Vacuum to 14 MPa (2 000 psi). Low uncertainty measurement provided by selection of quartz reference pressure transducer(s) (Q-RPTs)
Operating Medium	Any clean, dry, non-corrosive gas
	⚠ Warning
	User is responsible for any and all safety precautions associated with hazardous, flammable or toxic gas ventilation and containment.
Pressure Connections	TEST (+), TEST (-): 1/8 in. NPT F SUPPLY: 1/8 in. NPT F EXHAUST: 3/8 in. NPT F ATM: 10-32 UNF

1.2.2 Pressure Measurement Specifications

1.2.2.1 Quartz Reference Pressure Transducer (Q-RPT)

Quartz reference pressure transducers (Q-RPTs) can be installed in PPC4 to obtain low uncertainty pressure measurement. One or two Q-RPTs can be included in the PPC4 and/or additional Q-RPTs can be used externally mounted in a **DHI** RPM4 Reference Pressure Monitor (see Section 3.2.5).

The type (Axxx, Gxxx, BGxxx, BAxxx) and range of the Q-RPT module(s) determines the PPC4 measurement specifications.

All Q-RPTs whose maximum pressure is over 200 kPa (30 psi) are of the absolute pressure type (Axxx) using an evacuated, permanently sealed reference. Axxx Q-RPTs can measure absolute, gauge and negative gauge pressure. Gauge pressure with an Axxx (absolute) Q-RPT is obtained by offsetting atmospheric pressure and applying dynamic compensation for atmospheric changes using the on-board barometer (see Section 3.2.4). Gxxx (gauge) Q-RPTs can measure positive gauge pressure only. BGxxx (bi-directional gauge) Q-RPTs can measure gauge and negative gauge pressure. See Section 3.2.11 for additional information on absolute, gauge and negative gauge measurement modes.

PPC4s configured with two Q-RPT modules have only one TEST(+) and TEST(-) port. PPC4 internal valves and logic handle switching between the two Q-RPTs as needed.

Note

Q-RPTs are available with three different performance levels, PREMIUM class, STANDARD class, and FULL SCALE STANDARD class. See the product label on the PPC4 rear panel, the label on the Q-RPT module on the rear panel and/or the product calibration reports to determine the class of the Q-RPTs installed in PPC4.

Table 1. Reference Pressure Transducer (Q-RPT) Designations and Ranges

RPT DESIGNATION	SI VERSION		US VERSION	
	MAXIMUM PRESSURE Absolute [kPa]	MAXIMUM PRESSURE Gauge [kPa]	MAXIMUM PRESSURE Absolute [psi]	MAXIMUM PRESSURE Gauge [psi]
A14M ¹	14 000	14 000	2 000	2 000
A10M ¹	10 000	10 000	1 500	1 500
A7M ¹	7 000	7 000	1 000	1 000
A3.5M ¹	3 500	3 500	500	500
A2M ¹	2 000	2 000	300	300
A1.4M ¹	1 400	1 400	200	200
A700K ¹	700	700	100	100
A350K ¹	350	250	50	35
A200K ¹	200	100	30	15
A160K ¹	160	60	23	8

RPT DESIGNATION	SI VERSION		US VERSION	
	MAXIMUM PRESSURE Absolute [kPa]	MAXIMUM PRESSURE Gauge [kPa]	MAXIMUM PRESSURE Absolute [psi]	MAXIMUM PRESSURE Gauge [psi]
A100K ¹	110	10	16	1.5
G200K ²	--	200	--	30
G100K ²	--	100	--	15
G15K ²	--	15	--	2.2
BG15K ³	--	-15 to 15	--	-2.2 to 2.2
BA100K ⁴	70 to 110	-	10.2 to 16	--

1. All AXXXX RPTs support absolute, gauge and compound (negative) gauge modes.
2. All GXXXX RPTs are positive gauge mode only.
3. BG15K is bi-directional gauge from - 15 to + 15 kPa (- 2.2 to + 2.2 psi).
4. BA100K is a barometric range whose low point is 70 kPa absolute (10 psi).

Warm Up Time	None required, 30 minute temperature stabilization recommended for best performance from cold power up
Resolution	To 1 ppm, user adjustable
Acceleration Effect	± 0.008 % /g maximum, worst axis Allows operation at ± 20° from reference plane without significant effect
Predicted One Year Stability¹	± 0.005% of reading (gauge mode, or absolute with regular use of AutoZero)

	Full Scale Standard (f)	Standard (s)	Premium (p)
Precision²	± 0.011% of AutoRanged span ⁴	± 0.008% of reading or 0.0024% of Q-RPT span, whichever is greater ⁵	± 0.005% of reading, 0.0015% of AutoRanged span, or 0.0005% of Q-RPT span, whichever is greater ⁶
Measurement Uncertainty³	± 0.015% of AutoRanged span ⁴	± 0.01% of reading or 0.0030% of Q-RPT span, whichever is greater ⁵	± 0.008 % of reading, 0.0024% of AutoRanged span, or 0.0007% of Q-RPT span, whichever is greater ⁶

1. Predicted Q-RPT measurement stability limit (k=2) over one year assuming regular use of AutoZero function. AutoZero occurs automatically in gauge mode whenever vented, by comparison with barometric reference in absolute mode. Absolute mode predicted one year stability without AutoZ is ± (0.005% Q-RPT span + 0.005% of reading).
2. Combined linearity, hysteresis, repeatability. Add + 1 Pa (0.00015 psi) in gauge mode with an Axxx (absolute) Q-RPT for the resolution and short term stability of the on-board barometer.
3. Maximum deviation of the Q-RPT indication from the true value of applied pressure including precision, predicted one year stability limit, temperature effect and calibration uncertainty, combined and expanded (k=2) following the ISO "Guide to the Expression of Uncertainty in Measurement."
4. % of AutoRanged span, but with AutoRanged span no lower than 30% of Q-RPT span (10% with BG15K and G15K). For example, if the Q-RPT is a Full Scale Standard A160K, the Measurement Uncertainty in pressure is 0.015% times the AutoRanged span for any AutoRanged span from 160 kPa to 48 kPa (160 kPa span x 30%) and 7.2 Pa (160 kPa span x 30% x 0.015%) for any AutoRanged span less than 48 kPa.
5. % of reading value times measured pressure from 100 to 30 % of Q-RPT span. Under 30 % of Q-RPT span, % of reading value times 30 % of Q-RPT span. For example, if the Q-RPT is a Standard A160K, the Measurement Uncertainty in pressure is 0.010% times the measured pressure to 48 kPa (160 kPa span x 30%) and 0.0048 kPa (160 kPa span x 30% x 0.01%) under 48 kPa.
6. % of reading value times measured pressure from 100 to 30 % of AutoRanged span. Under 30% of AutoRanged span, % of reading value times 30% of Q-RPT span, whichever is greater. For example, if the Q-RPT is a Premium A160K and AutoRanged span is 160 kPa, the Measurement Uncertainty in pressure is measured pressure x 0.008% to 48 kPa (160 kPa AutoRanged span x 30%) and 0.0038 kPa (160 kPa span x 30% x 0.008%) under 48 kPa. If the AutoRanged span is 100 kPa (greater than 30% of 160 kPa maximum Q-RPT span), the measurement uncertainty in pressure is measured pressure x 0.008% to 30 kPa (100 kPa AutoRanged span x 30%) and 0.0024 kPa (100 kPa span x 30% x 0.008%) under 30 kPa. If the AutoRanged span is 30 kPa (less than 30% of the 160 kPa maximum Q-RPT span), the measurement uncertainty in pressure is measured pressure x 0.008% to 14.4 kPa (160 kPa maximum Q-RPT span x 9%) and 0.0012 kPa (160 kPa maximum Q-RPT span x 9% x 0.008%) under 14.4 kPa.

Note: DHI technical note 8050TN11 provides a detailed description of PPC4 Q-RPT uncertainties.

1.2.2.2 Utility Sensor

The PPC4 may be configured with a Utility sensor instead of a Hi Q-RPT. Utility sensors are used for pressure control, system monitoring and safety functions. They are intended for indication only, not to provide reference pressure measurement. Q-RPTs (see Section 1.2.2.1) are used for reference measurement.

Warm Up Time	None required
Ranges	14 MPa (2 000 psi) absolute and gauge 7 MPa (1 000 psi) absolute and gauge 2 MPa (300 psi) absolute and gauge 700 kPa (100 psi) absolute and gauge 300 kPa (45 psi) absolute / 200 kPa (30 psi) gauge
Resolution	0.001 % of span
Precision	0.1 % of span

1.2.2.3 On-Board Barometer

The on-board barometer is used only to measure changes in atmospheric pressure to provide dynamic compensation of the Q-RPT's atmospheric pressure offset when using an Axxx (absolute) Q-RPT to make gauge pressure measurements.

Warm Up Time	None required
Range	70 to 110 kPa (10 to 16 psi)
Resolution	0.001 % of span
Precision	0.1 % of span
Predicted Stability	0.05 kPa/yr (0.008 psi/yr)

Note

The on-board barometer is only present in PPC4s that have an Axxx (absolute), BG15K (bi-directional gauge) or G15K (gauge) internal Q-RPT.

1.2.3 Pressure Control Specifications

Control Precision	$\pm 0.0004\%$ of Q-RPT span or $\pm 0.00004\%$ of Hi Q-RPT span, whichever is greater or $\pm 0.0008\%$ of Q-RPT span if active Q-RPT is external.
Lowest controllable Pressure (gauge mode)	Zero set by automated venting. Lowest point above or below zero limited only by Q-RPT resolution and control precision.
Lowest controllable Pressure (absolute, negative gauge modes)	0.05% of Q-RPT span or 1 kPa, whichever is greater
Ultimate Pressure (absolute, negative gauge) Depending on vacuum pump and connections	50 Pa (0.5 mbar, 0.007 psia) typical with low ultimate pressure option 200 to 700 Pa (2 to 7 mbar, 0.03 to 0.1 psia) without low ultimate pressure option
Typical Pressure Setting Ready Time (0.005% hold limit, 50 cc test volume)	15 to 35 s
Slew Time (ATM to FS with 50 cc test volume)	30 s
Typical Test Volume	0 to 1000 cc for Q-RPT span 2 MPa [300 psi] or less 0 to 500 cc for Q-RPT span greater than 2 MPa [300 psi]
Default Dynamic Control Hold Limit	$\pm 0.005\%$ of current range



2. Installation

2.1 Unpacking And Inspection

2.1.1 Removing From Packaging

PPC4 is delivered in a corrugated container with suspension packaging; or in an optional molded shipping case with custom foam inserts.

Remove the PPC4 and its accessories from the shipping container and remove each element from its protective plastic bag.

2.1.2 Inspecting Contents

Check that all items are present and have no visible damage.

A PPC4 includes all items indicated in Table 2.

Table 2. PPC4 Packing List

DESCRIPTION		PART #
1 ea.	PPC4 Pressure Controller/Calibrator	3336095
1 ea.	Calibration Report	3152121
1 ea.	Test Report	3126112
ACCESSORIES:		3305585 (3305597)
1 ea.	Operation and Maintenance Manual	3306047
1 ea.	Drivers Connector	3069838
1 ea.	USB Cable, 2 Meter, Shielded	1626219
1 ea.	Power Cord (7.5 ft.)	3133781 (3153005)
1 ea.	General Accessories CD	3139043
2 ea.	Bulkhead Retainer, ½ in. hex	3138166
2 ea.	M4 Split Lock Washer	3153914
2 ea.	M4 x 8 Screw, BHSC	3361394
2 ea.	M3 x 20 Screw, SHC	3133921

2.2 Site Requirements

The PPC4 can be installed on any **flat, stable surface** at a convenient height. The front feet can be extended so that the unit can be inclined for easier viewing. The PPC4 can also be mounted in a standard 19 in. rack using the optional rack mount kit.

Minimizing the distance between the PPC4 and the device or system under test will enhance control performance and reduce pressure setting times.

Ready access to the PPC4 rear panel should be considered to facilitate making and breaking pressure connections.

Pneumatic and communications connections to a RPM4 pressure monitor should be considered if a RPM4 pressure monitor will be used as an external reference pressure measurement device (see Section 2.3.6).

The Self Purging Liquid Trap (SPLT), if used, should be mounted vertically at the low point of the connection between the PPC4 **TEST(+)** port and the test (see Section 2.3.7.1).

If you are using a G15K or BG15K Q-RPT with a Dual Volume Unit (DVU), its location and connections should be considered (see Section 2.3.7.2).

Support facilities required include:

- **An electrical power source** of 100 to 240 VAC, 50 - 60 Hz.
- **A continuous, regulated pressure supply** of clean, dry, non-corrosive gas at PPC4 maximum control pressure + 10 % (70 kPa (10 psi) in the case of a BG15K Q-RPT) to be connected to the PPC4 **SUPPLY** port. Lower gas pressure supply can be used but should exceed the maximum desired test output pressure by 10 to 20 %.
- **A vacuum source** of less than 1 psia (7 kPa) and with displacement of at least 90 lpm (3 cfm) if control of pressures under 3 psi (20 kPa) gauge is desired.

2.3 Setup

2.3.1 Preparing For Operation

To prepare PPC4 for check out and operation:

- ❶ Remove the plastic caps from the PPC4 rear panel pressure connections.
- ❷ Remove the protective plastic sheet from the front panel display.
- ❸ Familiarize yourself with the front and rear panel (see Section 2.3.2).

Then proceed with Sections 2.3.3 to 2.3.10.

2.3.2 Front And Rear Panels

2.3.2.1 Front Panel

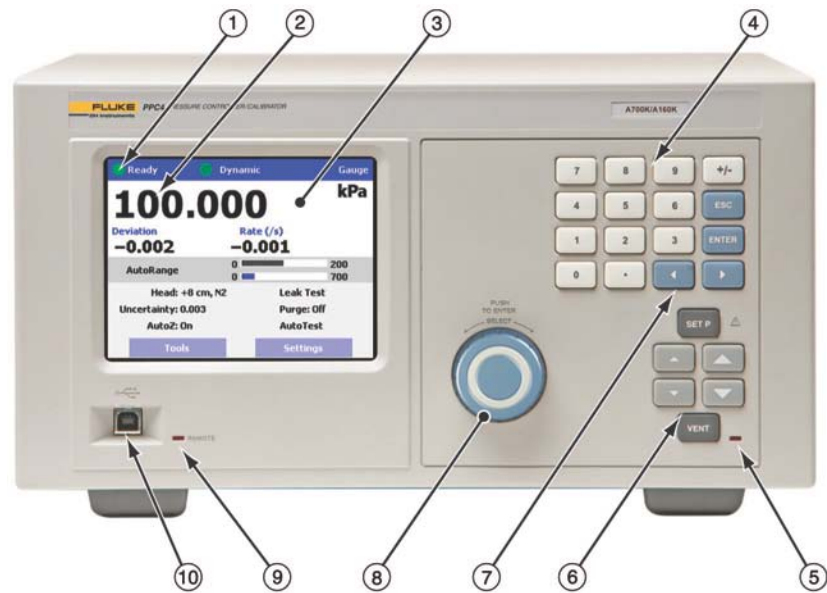

- | | |
|-----------------------------------|--------------------------------|
| ① Ready/Not Ready indicator | ⑥ Direct pressure control keys |
| ② Controlled pressure measurement | ⑦ Cursor control keys |
| ③ Display | ⑧ <i>Select and Enter</i> knob |
| ④ Multi-function keypad | ⑨ Remote activity indicator |
| ⑤ Vent Indicator | ⑩ USB connection |

Figure 1. PPC4 advanced interface front panel

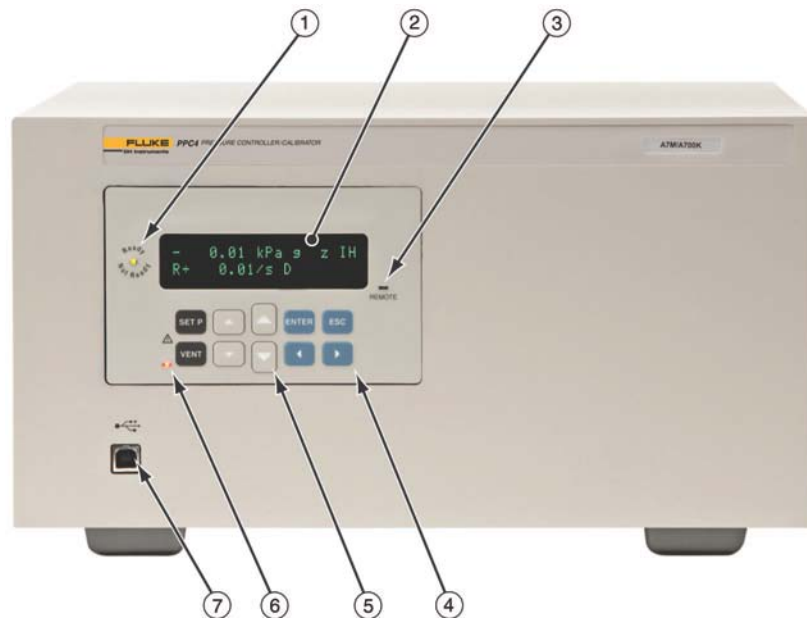

- | | |
|-----------------------------|--------------------------------|
| ① Ready/Not Ready indicator | ⑤ Direct pressure control keys |
| ② Display | ⑥ Vent Indicator |
| ③ Remote activity indicator | ⑦ USB connection |
| ④ Cursor control keys | |

Figure 2. PPC4 basic interface front panel

2.3.2.2 Rear Panel

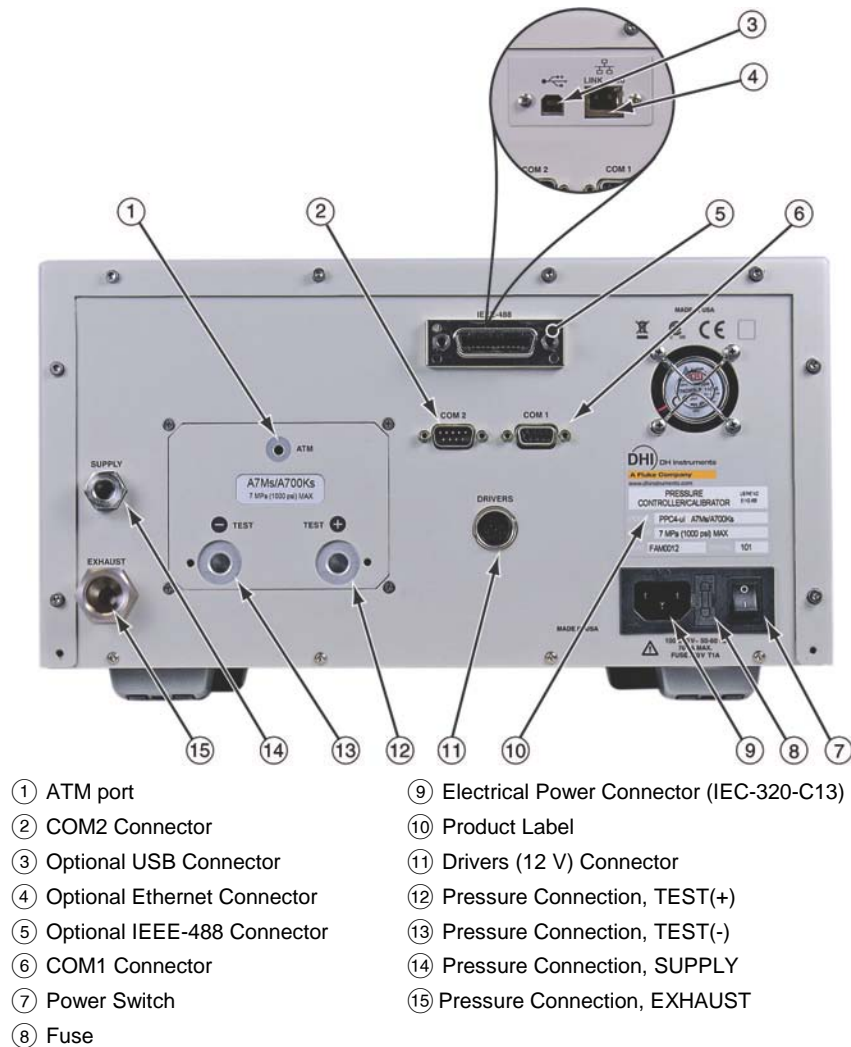

Figure 3. Rear panel with optional connectors

2.3.3 Power Connection

- ❶ Check that the PPC4 power switch is OFF.
- ❷ Connect the supplied power cable to the rear panel power module.
- ❸ Connect the other end of the power cable to an electrical supply of 100 to 240 VAC, 50-60 Hz.

2.3.4 Connecting To A Pressure Supply (Supply Port)

Using a pressure connecting hose or tube of appropriate pressure rating, connect the pressure supply to the **SUPPLY** port on the rear panel of PPC4. The PPC4 **SUPPLY** port connection is **1/8 in. NPT female**.

The supply pressure should be equal to the maximum PPC4 control pressure + 10 % (or 70 kPa (10 psi) for a BG15K Q-RPT). Lower gas pressure sources can be used but should exceed the maximum desired test output pressure by 10 to 20 %.

⚠ Caution

Never connect a pressure supply greater than 20 % over the maximum pressure of the PPC4 Hi Q-RPT you are using (except when the Hi Q-RPT is a BG15K Q-RPT). Be sure to connect the pressure supply to the SUPPLY port. Connecting to another port can damage the PPC4.

2.3.5 Connecting A Vacuum Pump (Exhaust Port)

For PPC4 to set pressures under atmosphere and/or to reliably set pressure under 20 kPa (3 psi) gauge (other than zero gauge), a vacuum supply must be connected to the EXHAUST port.

⚠ Caution

- Never connect a pressure supply to or plug the PPC4 EXHAUST port.
- To avoid building up pressure on the EXHAUST port or on a vacuum pump connected to the EXHAUST port, the vacuum source should either be continuously ON or the EXHAUST port should be bypassed to atmosphere when the vacuum source is OFF. This is because when a supply pressure is applied to the PPC4 SUPPLY port and the PPC4 is NOT in the vent ON condition, there is typically a constant gas exhaust through the PPC4 EXHAUST port.

Note

To ensure optimum pressure control when changing the pressure applied to the EXHAUST port from vacuum to atmosphere or vice-versa, be sure to change the control reference setting if the setting is NOT in AUTO mode (see Section 3.2.27.1).

2.3.6 Connecting External Q-RPTS In RPM4 Reference Pressure Monitor

PPC4 can be connected pneumatically and by RS232 to a RPM4 reference pressure monitor to use up to two external Q-RPTs in RPM4 as external reference pressure measurement devices (see Section 3.2.5).

The PPC4 then manages communications and other RPM4 functions to integrate the RPM4 measurement capabilities into the PPC4 system. The RPM4 Q-RPT module's Self Defense System (SDS) is used to shut-off RPM4 Q-RPTs from the pressurized system when they are not in use (see the RPM4 Operation and Maintenance Manual).

Note

As a general rule, making the pneumatic connection between the PPC4 TEST port and the remote Q-RPT as direct as possible favors good pressure control. As distance, volumes and restrictions between the PPC4 TEST port and the remote Q-RPT are added, the possibility of difficulty with pressure control when using the external Q-RPT increases.

To connect a PPC4 to an RPM4 to be used as part of the PPC4 system, proceed as follows:

Note

Set up the RPM4 for use as an external device to PPC4 following the instructions in the RPM4 Operation and Maintenance Manual, Using RPM4 with a PPCx Controller/Calibration Section.

- ❶ Using tubing of appropriate pressure rating and a Tee, connect the RPM4 Q-RPT **TEST(+)** port to the PPC4 **TEST(+)** port. The third leg of the Tee is for the connection to the device or system under test.

Note

- If a RPM4 Q-RPT will be used in a gauge pressure range of less than 100 kPa (15 psi), consider connecting the RPM4 Q-RPT module **TEST(-)** port to the PPC4 **TEST(-)** port and to the “low” connection of the UUT if available. This will improve pressure control and stability when ambient pressure is unstable. If the Q-RPT is an Axxx designation Q-RPT, this connection should be made but also be left open to atmosphere.
 - When external Q-RPTs are used with PPC4, the maximum set pressure is the maximum pressure of the PPC4 controller/calibrator. The maximum pressure of the PPC4 is determined by the PPC4 Hi Q-RPT or utility sensor (see Section 1.2.1).
- ❷ Using a standard pin-to-pin DB-9M to DB-9F RS232 cable, connect **COM2** of the PPC4 to **COM1** of the RPM4 (see Section 6.3.1.2).
 - ❸ Turn ON the PPC4 and RPM.
 - ❹ Select **<RPT>** in the Main Menu in the Basic interface (see Section 4.5.12) or **[AutoRange]**, **Range:** from the Main Run Screen in the Advanced user interface. Q-RPTs with whom communication is established will be shown on the PPC4 display identified by their position (see Table 3).

Note

- For PPC4 to identify external RPM4, the RPM4 **COM1** port settings must be:
 - Baud rate: between 1200 and 19200
 - Parity: Even
 - Data bits: 7
 - Stop bits: 1
- If PPC4 is not able to establish communications with an RPM4 and its Q-RPTs, check that the RPM4 **COM1** port settings conform to the requirements above. If the **COM1** port settings are correct, check that the correct communications cable is being used (standard pin-to-pin DB-9M to DB-9F RS232) and is connected to the correct communications ports.
 - PPC4 COM2 > RPM4 COM1
- See the RPM4 Operation and Maintenance Manual for additional information on RPM4 RS232 communications and COM port settings.

2.3.7 Connecting To The Device Under Test (Test(+)) And Test(-) Ports

If you are using a self purging liquid trap (SPLT), see Section 2.3.7.1 before proceeding to connect the device under test.

If the PPC4 has a G15K or BG15K Q-RPT, a dual volume unit (DVU) should be installed for very low pressure control. See Section 2.3.2.2 before proceeding to connect to the device under test.

Using a pressure connecting hose or tube of appropriate pressure rating, connect the device or system to be tested to the PPC4 **TEST(+)** port. The PPC4 **TEST(+)** connection is **1/8 in. NPT female**.

PPC4 TEST(+) AND TEST(-) PORTS

All PPC4s have a **TEST(+)** and a **TEST(-)** port. See Figure 32 for PPC4 internal Q-RPT **TEST** port configurations.

The **TEST(+)** port is connected to Axxx (absolute) Q-RPTs and to the **high** side of Gxxx or BGxxx (gauge, bi-directional gauge) Q-RPTs.

The **TEST(-)** port is connected to PPC4s internal barometer, if present, and to the **low** side of Gxxx or BGxxx (gauge, bi-directional gauge) Q-RPTs.

- **When operating in absolute mode:** The **TEST(-)** port is left open to atmosphere.
- **When operating in gauge or negative gauge mode with a range greater than 50 kPa (7.5 psi):** The **TEST(-)** port is normally left open to atmosphere. A possible exception is when the device or system under test is in an ambient pressure that may differ significantly from the ambient pressure around the PPC4. For example, if the PPC4 is controlling pressure into UUTs in an environmental chamber, the pressure in the environmental chamber may be different from ambient pressure around the PPC4. In this case, connecting a tube from the **TEST(-)** port to the inside of the chamber may improve measurement results. If the Q-RPT in use is an Axxx Q-RPT, this tube must be left open to the environment so that the pressure inside cannot deviate too far from ambient. When using an Axxx Q-RPT, if this tube is connected to the low or reference side of UUTs, be sure to open to the local environment as well.
- **When operating in gauge or negative gauge mode with a range less than 50 kPa (7.5 psi):** As a general rule, it is preferable to connect the PPC4 **TEST(-)** port(s) directly to the low or reference side of the device under test to ensure that these are at the same pressure. When using an Axxx Q-RPT, this connection must also be open to atmosphere. When using a Gxxx or BGxxx Q-RPT, it is preferable that this connection not be open to atmosphere.

Caution

- **Do not apply pressure to the TEST(+) port without having a pressure supply equal to or greater than the applied pressure connected to the SUPPLY port. When controlling pressure to the TEST(+) port externally, do not cause the pressure to change at a rapid rate. For example, do not vent suddenly by opening an external valve. Internal damage to the PPC4 may result.**
- **Do not connect a pressure supply to the TEST(-) port. The pressure applied to this port should be maintained at atmospheric pressure, between 70 and 110 kPa (10 and 16 psia). Exceeding these limits may damage a Gxxx or BGxxx Q-RPT and/or the PPC4's on-board barometer.**
- **Operating the PPC4 connected to a system with liquid contaminants without taking proper precautions to purge the system and test line may cause contamination of the PPC4 that will require non-warranty service.**

Note

- **Minimizing the length of the test connection tubing will enhance control performance and reduce pressure setting time. For normal operation, the total volume of the device or system under test including connecting tubing should be less than 1 000 cc (60 in³) up to 2 000 kPa (300 psi) and less than 500 cc (30 in³) above 2 000 kPa (300 psi).**
- **PPC4 pressure control will not operate properly if there are excessive leaks in the test system. In general, the maximum acceptable leak rate for optimal PPC4 automated pressure control operation and to ensure in tolerance measurements with default pressure control parameters is ± 0.5 % of set pressure/minute. In DYNAMIC CONTROL mode, to handle higher test system leak rates, increase the hold limit using**

CUSTOM CONTROL (see Section 3.2.13).

- **PPC4 pressure control may be adversely affected if the test connection tubing is too restrictive. For optimum results, the inner diameter of the connecting hose should be at least 1.75 mm (0.07 in.).**

2.3.7.1 Installing a Self Purging Liquid Trap (SPLT)

The SPLT (optional) is intended to collect and exhaust liquid or other contaminants that may be present in the device or system under test so that they do not return to contaminate the PPC4.

The SPLT is installed in the **TEST(+)** connection line at a low point between PPC4 and the device or system under test. If the PPC4 system includes external Q-RPTs in an RPM4, the RPM4 should be connected on the PPC4 side of the SPLT.

See the SPLT Operation and Maintenance manual for more complete instructions on SPLT installation.

2.3.7.2 Installing a Dual Volume Unit (DVU), G15K and BG15K Q-RPTS

To achieve in tolerance pressure control with the very low range of the G15K and BG15K Q-RPTs, a PK-PPC-BG-DVU dual volume unit should be installed in-line on the **TEST(+)** and **TEST(-)** ports. The DVU includes two thermally isolated volumes installed in the test line to improve control stability.

See the PK-PPC-BG-DVU instruction sheet for additional information on its installation.

2.3.8 The ATM Port

The PPC4 **ATM** port is the system vent to atmosphere point used to set zero gauge pressure as well as to obtain Q-RPT measurements of atmospheric pressure. Though a pressure hose can be connected to the **ATM** port to direct the vented gas flow, a completely unobstructed connection to atmosphere must be maintained for PPC4 reference pressure measurements to operate normally.

The PPC4 **ATM** port fitting is **10-32 UNF**.

Caution

NEVER plug, obstruct or connect a supply pressure to the PPC4 ATM port. This may adversely affect GAUGE mode operation and AutoZeroing functions.

2.3.9 Check/Set Security Level

PPC4 has a security system based on user levels. By default, the security system is set to “low”, which includes certain access restrictions, and there is no password required to change the security level. See Section 3.2.26.4 for information on the security level system. As part of the PPC4 startup, determine the security level that is appropriate for the PPC4 and set a password if desired.

Caution

PPC4 is delivered with the security level set to “low” to avoid inadvertent altering of critical internal settings but with access to changing security levels unrestricted. It is recommended that the low security level be maintained at all times and password protection be implemented if control over setting of security levels is desired.

2.3.10 Turn Off Absolute And Negative Gauge Mode (Axxx RPT)

If your PPC4 has an Axxx (absolute) Q-RPT, it is able to operate in gauge, negative gauge and absolute measurement modes (see Section 3.2.11). If the PPC4 will be used only in gauge mode, the other measurement modes can be turned off so they are no longer accessible. This can avoid confusion and/or accidental use of the wrong measurement mode. See Section 7.2.5 for complete information on turning off absolute and negative gauge measurement modes.

2.4 Power-Up And Verification

2.4.1 Switch Power On

Actuate the power switch on the PPC4 rear panel. Observe the front panel display as PPC4 initializes error checks and goes to the Main Run Screen (see Sections 4.1 and 5.1).

PPC4 power-up condition is Internal, Hi Q-RPT or utility sensor active, VENT ON unless the pressure measured by the Hi Q-RPT is more than 20 kPa (3 psi) away from standard atmospheric pressure.

If the PPC4 fails to reach the Main Run Screen, service is required. Record the sequence of operations and displays observed.

2.4.2 Check Pressure Measurement Operation

2.4.2.1 Checking Absolute Mode Pressure Measurement

If the PPC4 is not vented (VENT LED OFF), **VENT** to vent the PPC4 (VENT LED ON) (see Section 3.2.14) and wait for a *Ready* indication (see Section 3.2.3).

2.4.2.1.1 Basic Interface

Select <Range> in the Main Menu to change ranges if necessary and select the Axxx (absolute) Q-RPT DF range (see Section 4.4.1). Press <Mode> in the Main Menu and select <Absolute> mode (see Section 3.2.11). Use <Unit> under the Main Menu to change the pressure unit if desired (see Section 3.2.10).

Observe the current value of atmospheric pressure. Check that the value agrees with the local value of atmospheric pressure. Repeat this process for all the Axxx (absolute) Q-RPTs and or the utility sensor in the PPC4 system. Check that the values of atmospheric pressure measured by the different devices agree with each other within PPC4 or RPM4 measurement tolerances as applicable (see Section 1.2.3). If they do not agree within tolerances, the PPC4 or RPM4 Q-RPT may need calibration or repair.

2.4.2.1.2 Advanced Interface

Use **[AutoRange], Range:** to select the DF range of the Axxx (absolute) Q-RPT (see Section 5.7.1). *Enter* (click) the measurement mode shortcut (see Sections 5.1 and 5.7.6.2) to change to Absolute mode. *Enter* the unit shortcut (see Sections 5.6.1 and 5.7.6.1) to change the pressure unit if desired.

Observe the current value of atmospheric pressure. Check that the value agrees with the local value of atmospheric pressure. Repeat this process for all the Axxx (absolute) Q-RPTs and or the utility sensor in the PPC4 system. Check that the values of atmospheric pressure measured by the different devices agree with each other within PPC4 or RPM4 measurement tolerances as applicable (see Section 1.2.3). If they do not agree within tolerances, the PPC4 or RPM4 Q-RPT may need calibration or repair.

2.4.2.2 Checking Gauge Mode Pressure Measurement

If the PPC4 is not vented, **VENT** to vent it (see Section 3.2.14).

Note

It is normal for PPC4 to indicate a value other than zero when vented when gauge mode is first entered or ranges are changed. After about ten seconds, the vent LED should flash and zero should be indicated. If this does not occur, check that the AutoZero function is ON (see Section 3.2.22). If AutoZero is ON and the displayed pressure will not zero when vented in gauge or bi-directional gauge measurement mode, PPC4 may need repair.

2.4.2.2.1 Basic Interface

Select <Range> in the Main Menu to change ranges if necessary and select the Axxx (absolute) Q-RPT DF range (see Section 4.4.1). Press <Mode> in the Main Menu and select <Gauge> mode (see Section 3.2.11). Use <Unit> under the Main Menu to change the pressure unit if desired (see Section 3.2.10).

Observe that, within ten seconds, zero is indicated. It is normal for PPC4 to indicate a value other than zero for up to ten seconds when first entering gauge mode.

Select <Range> under the Main Menu to change ranges, observe that zero is indicated for each Q-RPT within 10 seconds.

2.4.2.2.2 Advanced Interface

Use **[AutoRange], Range:** to select the DF range of the Axxx (absolute) Q-RPT (see Section 5.7.1). *Enter* (click) the measurement mode shortcut (see Sections 5.1 and 5.7.6.2) to change to Absolute mode. *Enter* the unit shortcut (see Sections 5.6.1 and 5.7.6.1) to change the pressure unit if desired.

Observe that, within ten seconds, zero pressure is indicated. It is normal for PPC4 to indicate a value other than zero for up to ten seconds when first entering gauge mode.

Use **[AutoRange], Range:** to change ranges, observe that zero pressure is indicated for each Q-RPT within 10 seconds.

2.4.3 Leak Test

If desired, perform a leak check of the test system (see Section 3.2.18).

2.4.4 Purge

If an SPLT is included and installed in the test line (see Section 2.3.7.1) and the Device Under Test (UUT) may be contaminated with liquids, perform a purge of the UUT (see Section 3.2.27.4). The Purge function must first be enabled (see Section 4.5.7.4 for Basic Interface and Section 5.7.12.3 for Advanced Interface). This will rid the UUT of contaminating liquids.

Caution



Operating the PPC4 connected to a system with liquid contaminants without taking proper precautions to purge the system and test line may cause contamination of the PPC4 that will require non-warranty service.

2.4.5 Check Pressure Control Operation

2.4.5.1 Basic Interface

Select a pressure range using in the Main Menu <Range> selection (see Section 4.4.1).



In the Main Menu press <Setup>, <Control>, <Dynamic> (see Section 3.2.2.1).  to return to the Main Run Screen.

, key in a target pressure within the active range and . (see Section 4.2.1).

2.4.5.2 Advanced Interface

Select a pressure range using [\[AutoRange\]](#), [Range:](#) (see Section 5.7.1).

Select dynamic control mode with the control mode shortcut (see 5.6.1 and Section 5.7.8.2).  to return to the Main Run Screen.

, key in a target pressure within the active range and . (see Section 5.5.1).

Caution

Verify the maximum pressure rating of the system connected to the PPC4 TEST(+) port before entering a target pressure. Do not enter a target pressure greater than the pressure rating of the system connected to the PPC4 TEST(+) port.

PPC4 should set the target pressure and indicate *Ready* (see Section 3.2.3) continuously in 15 to 60 seconds. If it does not, see Section 8 to troubleshoot.

2.5 Short Term Storage

The following procedure is recommended for short term storage of PPC4:

- ❶ Vent the PPC4 test pressure.
- ❷ Turn the power OFF using the rear panel power switch.
- ❸ Shut OFF or disconnect the pressure supply.
- ❹ Shut OFF or disconnect the vacuum supply. Be sure the pressure supply is disconnected or the vacuum pump is bypassed from the PPC4 **EXHAUST** port before turning OFF the vacuum pump.



3. Operating Principles

3.1 User Interfaces

PPC4 is designed with two front panel local interface configurations. The Advanced Graphical User Interface version, PPC4-ui, is typically used for bench top operation. The limited function Basic Interface with the basic PPC4 is typically used for computer controlled applications such as automated calibration. See Section 4 for operation information on the Basic Interface. See Section 5 for operation information on the Advanced Interface.

Remote communication is by RS232 (COM1), IEEE-488, Ethernet or USB. See Section 6 for specific information on remote communication.

Every PPC4 ships with PPC4 Cockpit software as well. PPC4 Cockpit communicates with the PPC4 by RS232, Ethernet, IEEE-488 or USB. PPC4 Cockpit duplicates the functionality, look and feel of the advanced user interface and provides functionality and an easy to use interface for users of both basic PPC4 and PPC4-ui (see Section 6.2).

3.2 General Operating Principles

3.2.1 Direct Pressure Control

○ PURPOSE

The direct pressure control keys provide direct manual control to increase, decrease, and jog the PPC4 pressure.

○ OPERATION

▲ or ▼ (▲ or ▼ for the Basic Interface) cause pressure to increase or decrease at the fast slew rate.

▲ or ▼ when dynamic control is not active cause pressure to increase or decrease at the slow slew rate.

▲ or ▼ during dynamic control causes the pressure to jog or step by a fixed amount. During active pressure control, they cause the target pressure to be changed by the fixed amount. One press causes one step. The approximate value of the step is set automatically depending on the current active PPC4 range. The value can be adjusted with the Jog function (see Section 3.2.19).

⚠ Caution

The fast direct pressure control keys, ▲ and ▼, interrupt and override automated pressure control.

3.2.2 Automated Pressure Control

PPC4 automated pressure control provides automated adjustment and control of pressure to a user designated target value. **SET P** from the Main Run Screen allows a pressure control target value to be entered and executed. **ESC** or **SET P** cause active pressure control to be interrupted. Sending a remote command when in local mode also interrupts pressure control.

PPC4 supports two pressure control modes to meet different pressure setting and controlling requirements: dynamic and static. Pressure control parameters for each control mode are automatically set to optimal default values for the operating PPC4 range when the range is selected or AutoRange is used (see Section 3.2.8). Control parameters can be customized using screen selections (see Section 4.4.5.1 for Basic Interface and Section 5.7.8.2.1 for Advanced Interface selections).

Control parameters:

- Target Pressure** The pressure set point specified by the operator.
- Hold Limit** A symmetrical positive and negative limit around the target value within which the controlled pressure is maintained.
- Stability Limit** A rate of change of pressure limit in units of pressure/second used as a criterion for the *Ready/Not Ready* condition in static control or when PPC4 is idle (control not active).

Note

See Sections 3.2.2.1 and 3.2.2.2 (**Dynamic Control and Static Control**) for a detailed explanation of each control mode and its advantages, the default control parameters and the control customization options.

3.2.2.1 Dynamic Control

Dynamic control mode is designed to set the pressure to the target value and control continuously to keep pressure within the hold limit and as close to the target value as possible (see Figure 4) The advantage of this control mode is that the final pressure achieved is the same as the target value. The maximum value of the control error is equal to the hold limit. The average value of the control error is typically much smaller than the hold limit.

During dynamic pressure control, the hold limit is active. If the pressure goes outside of the hold limit, a *Not Ready* condition occurs. See Table 5 and Table 6 for default hold limit values. To customize the hold limit see Section 4.4.5.1 for Basic Interface and Section 5.7.8.2.1 for Advanced Interface.

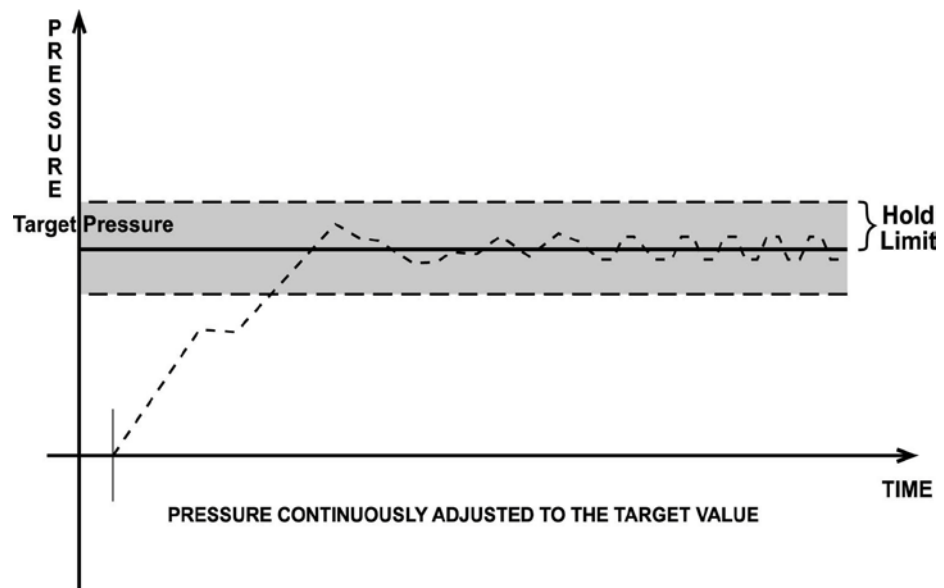

Figure 4. Dynamic Pressure Control Operation

3.2.2.2 Static Control

Static control mode is designed to set the pressure near the target value and then interrupt active control to allow pressure to stabilize naturally within the hold limit. The advantage of this control mode is that pressure can be set and/or measured within a defined limit of a target without interference from the pressure control system. In a system without excessive leaks, the pressure stability achieved may be greater than the stability with which the pressure control system can actively control pressure. Using static control to control pressure near the desired set point and then measuring back the stabilized pressure without interference of the control function can allow control errors to be completely eliminated. However, the final pressure achieved is not equal to the target value. During static pressure control, the hold limit is active. If the pressure goes outside of the hold limit, a *Not Ready* condition occurs (see Section 3.2.3) and pressure is readjusted to the target value (see Figure 5). For default values for hold and stability limits, see Table 5 and Table 6. To customize the hold and stability limits see Section 4.4.5.1 for Basic Interface and Section 5.7.8.2.1 for Advanced Interface.

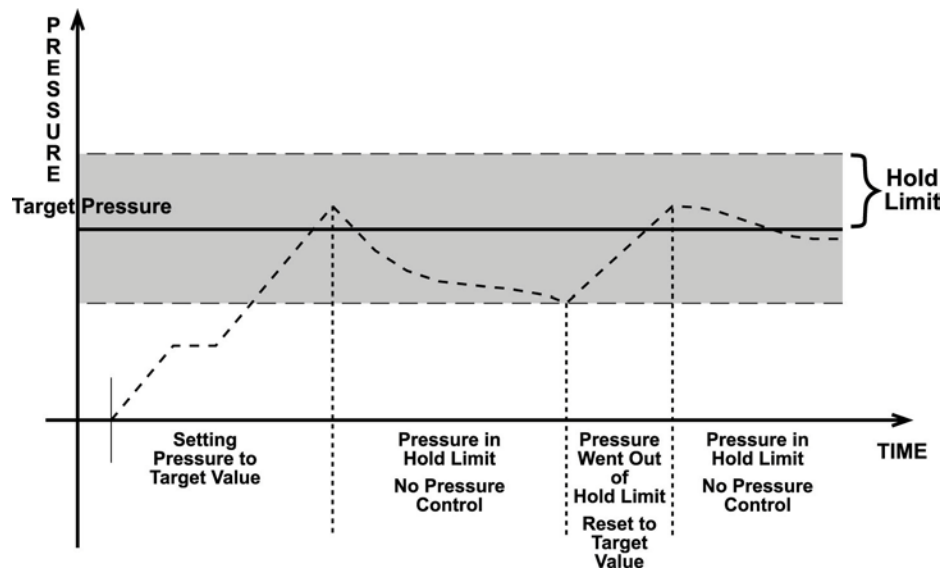

Figure 5. Static Pressure Control Operation

3.2.3 Pressure Ready/Not Ready

There is a *Ready/Not Ready* indicator on the PPC4 front panel. This indication is intended to provide the user with a clear and objective criterion for determining when a valid pressure measurement can be made.

The *Ready/Not Ready* LED indications are:

- <Green> Pressure **Ready**. PPC4 is either actively controlling the pressure and the criteria for a *Ready* condition to occur have been met or PPC4 is NOT actively controlling the pressure and the rate of change of pressure is within the stability limit.
- <Yellow> (Advanced Interface Only) Pressure **Near Ready**. PPC4 is actively controlling the pressure using fine pressure control and is close to meeting the criteria for a *Ready* condition.
- <Red > Pressure **Not Ready**. Either PPC4 is idle and pressure does not meet the stability test or PPC4 is actively controlling the pressure and **Ready** conditions have not yet been met.

When pressure control is NOT active: A *Ready* condition occurs any time NO control valve is operating and the pressure rate of change is inside the stability limit. The stability limit is defined in terms of rate of change of pressure in current pressure units per second.

When pressure control is active: The criteria for determining the *Ready/Not Ready* condition depend on whether the current control mode is static or dynamic. Pressure *Ready/Not Ready* parameters are set by default when AutoRange is used, or a control mode is selected. The parameters can be customized if desired (see Section 4.4.5.1 for Basic Interface and Section 5.7.8.2.1 for Advanced Interface).

Dynamic Control Ready/Not Ready

With dynamic pressure control active, a *Ready* condition occurs whenever:

- The current measured pressure is inside the hold limit.

Note

In dynamic control mode, it is common to assume that when a *Ready* condition occurs (pressure inside the control hold limit), the measured pressure equals the target pressure. For this reason, when the pressure is *Ready* in dynamic control mode, the measured pressure display is equal to the target pressure.

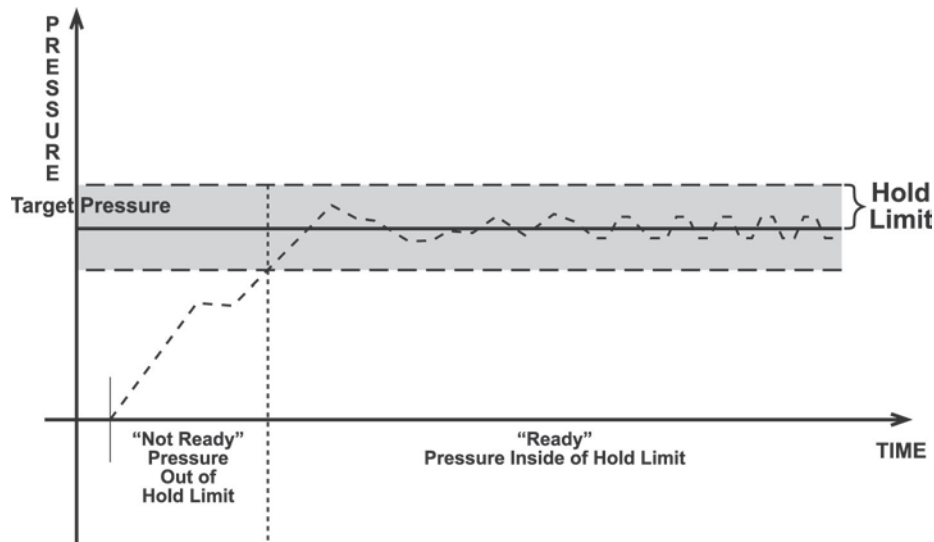

Figure 6. *Ready/Not Ready* in Dynamic Pressure Control Mode

Static Control Ready/Not Ready

With static pressure control active a *Ready* condition occurs whenever:

- NO control valve is operating.
- The current measured pressure is at the target value within the hold limit.
- The rate of change of pressure is less than the current stability limit.

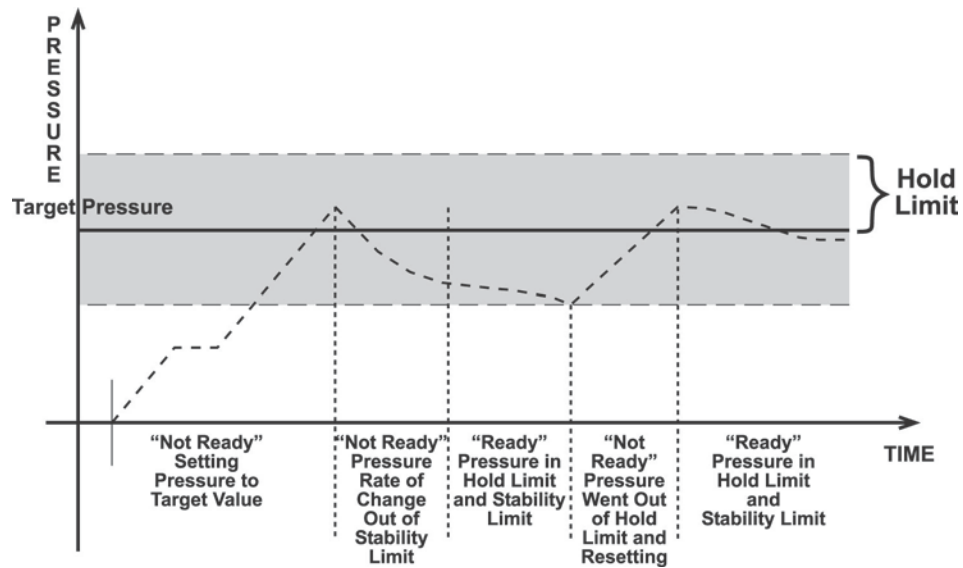

Figure 7. Ready/Not Ready in Static Control Mode

Ready/Not Ready When Not Actively Controlling

When NO automated pressure control is active, *Ready* is indicated whenever the rate of change of pressure is less than the current stability limit (see Section 4.4.5.1 for Basic Interface and Section 5.7.8.2.1 for Advanced Interface).

3.2.4 Gauge and Negative Gauge Modes with an Axxx (Absolute) Q-RPT, Dynamic Compensation for Atmospheric Pressure

Q-RPTs with the designation Axxx are intrinsically absolute but they are also used in gauge and negative gauge measurement modes (difference from atmosphere) (see Section 3.2.11). Gauge measurement mode is achieved by subtracting the value of atmospheric pressure, $P_{\text{offset,G}}$, from the Q-RPT's absolute reading using AutoZero (AutoZ, see Section 3.2.22). In gauge or negative gauge measurement mode, the AutoZ routine that measures $P_{\text{offset,G}}$, is run automatically whenever the PPC4 is in the vented condition. This ensures the continuous automated updating of the $P_{\text{offset,G}}$ value corresponding to atmospheric pressure. Gauge pressure is the measured absolute pressure, P_u , minus the atmospheric offset.

$$P_{\text{gauge}} = P_u - P_{\text{offset,G}}$$

However, atmospheric pressure can change between opportunities to run AutoZ and update the value of $P_{\text{offset,G}}$, for example when running an extended test without venting. PPC4 uses **dynamic compensation of atmospheric pressure** to correct for these changes in atmospheric pressure. When AutoZ executes, and $P_{\text{offset,G}}$ is determined, the reading of PPC4's on board barometer, $P_{\text{atm,0}}$, is also recorded. Later, when no longer vented, the change in atmospheric pressure, ΔP_{atm} since $P_{\text{offset,G}}$ was updated is the difference between the current barometer reading, P_{atm} , and the barometer reading at the time of AutoZ execution, $P_{\text{atm,0}}$:

$$\Delta P_{\text{atm}} = P_{\text{atm}} - P_{\text{atm,0}}$$

Dynamic compensation for atmospheric pressure uses ΔP_{atm} to correct the value of $P_{\text{offset,G}}$, thus always compensating real time for changes in atmospheric pressure:

$$P_{\text{gauge}} = P_u - P_{\text{offset,G}} - \Delta P_{\text{atm}}$$

Gauge pressure measurement on an Axxx (absolute) Q-RPT allows instantaneous switching between gauge and absolute measurements modes. Any additional uncertainty in gauge pressure mode due to the dynamic compensation for atmospheric pressure technique is a

function of the resolution and short term stability of the on-board barometer rather than its absolute measurement uncertainty. This additional uncertainty is ± 1 Pa (0.00015 psi).

3.2.5 Multiple Internal and External Q-RPTs

A base PPC4 pressure controller includes a high precision, utility pressure sensor whose range is equal to the controller's range. The utility sensor is not intended to serve as a pressure reference for low uncertainty measurement. It is for indication, pressure control, system safety and maintenance functions only.

To obtain low uncertainty, traceable pressure measurement, PPC4 uses Quartz Reference Pressure Transducers (Q-RPT). Up to four Q-RPTs can be included in a PPC4 pressure controller/calibrator system. One or two Q-RPTs can be built into the PPC4, up to two may be located outside the PPC4 enclosure, in an RPM4 reference pressure monitor (one or two in the RPM4). Once the Q-RPTs available to a PPC4 system have been set up and identified, their use is managed by PPC4 transparently to the operator.

The use of multiple Q-RPTs, combined with PPC4's infinite ranging capability and AutoRange feature (see Section 2.3.7), make it possible for a single PPC4 pressure controller/calibrator system to cover an extremely wide range of test ranges and measurement modes with low uncertainty in each range.

Communication between an external RPM4 and a PPC4 controller is by RS232 connection from PPC4's COM2 port. One common pressure connection can be made between the PPC4 and RPM4 pressure ports (see Section 2.3.6 for information on setting up a PPC4 with external RPM4). RPM4 Q-RPT modules' SDS function protects RPM4 Q-RPTs from overpressure when they are not in use.

The PPC4 RPT function (see Section 4.5.12 for Basic Interface and Section 5.7.1, RPT Search, for Advanced Interface) is used to identify Q-RPTs available to the PPC4. The PPC4 then manages the internal and external Q-RPTs transparently to the operator, selecting the appropriate Q-RPT for the range of operation and operating valves to connect and disconnect them as needed.

Each Q-RPT has a default range, which is its maximum range. It can also be downranged using PPC4's AutoRange function.

The PPC4 internal pneumatic layout for handling its utility sensor and one or two Q-RPTs depends on the number of Q-RPTs and their type (Axxx absolute, Gxxx gauge, BGxxx bi-directional gauge). Figure 32 provides pneumatic schematics of the different PPC4 internal utility sensor and Q-RPT configurations with a chart of valve status for various operating conditions.

⚠ Caution

- **Before operating PPC4 with external Q-RPTs, check carefully that the RPM4's Q-RPT TEST(+) port(s) is/are connected to the PPC4 TEST(+) port. If an external Q-RPT is NOT connected to the PPC4 TEST(+) port, it will NOT measure the pressure generated by PPC4 and PPC4 may reach a pressure higher than the target pressure before its watchdog function recognizes that the external Q-RPT is not connected (see Section 3.2.21.1). The PPC4 watchdog function monitors differences in the change in pressure indicated by an active, external Q-RPT and the PPC4 Hi utility sensor or Q-RPT (watchdog). If the difference becomes excessive, control is aborted, an audible warning sounds and a warning is displayed. If this occurs, make sure the PPC4 and RPM4 Q-RPT TEST(+) ports are connected together and try again.**
- **RPM4 with Q-RPT full scale spans below 14 MPa have SDS self defense system to isolate and protect the Q-RPTs. If an external RPM4 SDS pressure rating is less than the PPC4 maximum pressure then a warning will be displayed on the PPC4 front panel when the RPM4 is detected. In addition, AutoRanged ranges greater than the SDS rating**

are not allowed (see Sections 6.5.4, 3.2.8). In order to create AutoRanged ranges or generate pressures above the SDS pressure rating the RPM4 must be disconnected or the RPM4 SDS must be upgraded to a higher pressure rating. Upgrades may be done at the DH Instruments service center (see Table 36).

Position Identification of Q-RPTs In a PPC4 System

Position identification of the currently active Q-RPT or utility sensor in the PPC4 system is continuously displayed in the upper right hand corner of the Basic Interface Main Run Screen and most other screens. Position identification of the currently active Q-RPT or utility sensor is displayed by selecting **[AutoRange]** and viewing the **RPT:** field in the Advanced Interface. See **Table 3** for position designation protocol for the Q-RPTs available in a PPC4 system.

See Table 1 for a complete listing of Q-RPTs available and their default ranges.

Table 3. Position Designators of Q-RPTs in a PPC4 System

Q-RPT POSITION	IDENTIFICATION	DISPLAY SYMBOL*
Internal to PPC4, utility sensor, if present	Internal Utility, Hi	luH
Internal to PPC4, Q-RPT of maximum range	Internal Hi	IH
Internal to PPC4, Q-RPT with lower maximum range in PPC4 with two Q-RPTs or a utility sensor and Q-RPT.	Internal Lo	IL
External to PPC4, Q-RPT of higher maximum range in RPM4, if present	External Hi	X1H
External to PPC4, Q-RPT with lower maximum range in dual Q-RPT RPM4, if present	External Lo	X1L

* The display symbol is included in the upper, right hand corner of most Basic Interface displays/menus and in fields in AutoRange screens in the Advanced Interface.

3.2.6 Multiple Ranges (Q-RPTs, AutoRange and Infinite Ranging)

A PPC4 range is defined as a pressure span and associated settings.

A PPC4 may have multiple ranges. Each Q-RPT (and the utility sensor, if present) available to the PPC4 system has a default range which is its maximum span. Additional ranges, lower than the Q-RPT's maximum span, may be created using AutoRange (see Section 3.2.8). Ranges created using AutoRange may be saved with all their settings for reactivation later (see Section 5.7.1 for the Advanced Interface and Section 4.4.1.1 for the Basic Interface).

Most settings made in a PPC4 range, such as unit of measure, measurement mode, display resolution, control mode and control parameters are specific to the range. Many settings made while a range is active apply to that range and not other ranges. The range specific settings are stored with the range and recalled whenever the range is made active. This makes setting up and saving ranges a convenient way to store and recall frequently used operating configurations. See Table 4 for a listing of PPC4 adjustments and settings and whether they are range, Q-RPT or system specific.

The ranges available on a PPC4 system may be queried (Range) and/or created (AutoRange) with functions available locally. External Q-RPTs connected to the PPC4 may be initialized with RPT Search. For the Advanced interface see Sections 5.7.1. For the Basic Interface see Sections 4.5.14, 4.5.10 and 4.5.12.

Table 4. Settings and What They Are Specific To (Range, Measurement Mode, Q-RPT, System)

SETTING	PURPOSE	SPECIFIC TO	SECTION
Unit	Set pressure unit of measure	Range	3.2.10
Mode	Set pressure measurement mode (absolute, gauge, negative gauge)	Range	3.2.11
Resolution	Set pressure display resolution	Range	3.2.19
Jog	Set jog step size	Range	3.2.20
Control	Set pressure control mode and parameters	Range	3.2.13
Upper Limit	Set upper and lower pressure limit alarm	Range and measurement mode	3.2.21
AutoZ	Run AutoZ, ON/OFF, set and view value	Range and measurement mode	3.2.22
Screen Saver, Sound, Time, ID, Level	Set system user preferences	System	3.2.26
Head	Set fluid head correction height, fluid, unit of measure	System	3.2.16
Control reference	Set EXHAUST port pressure condition	System	3.2.27.1
Purge	Enable/disable purge function	System	3.2.17
Valve Drivers	Set status of external valve drivers	System	3.2.23
TEST (-) Vent	Set status of TEST(-) vent valve, if present	System	3.2.27.5
Calibration	Various Q-RPT and utility sensor calibration functions	Q-RPT, utility sensor or barometer	7.2, 7.3, 7.4

3.2.7 Operation with a PG7000 Piston Gauge

PPC4 can act as a pressure control source to automated setting pressure and floating the piston of a PG7000 gas operated piston gauge.

For automated operation, the PPC4 communicates with the PG7000 through an RS232 connection from the PG7000 COM3 port to the PPC4 COM1 port. Pressure control commands are sent from the PG7000 when it is in “AutoGen” mode (see the PG7000 Operation and Maintenance Manual).

The PPC4 may also be operated manually using its direct pressure control keys (see Section 3.2.1).

3.2.8 AutoRange

○ PURPOSE

To automatically set up PPC4 to optimize its measurement and control characteristics and features to cover a specific pressure range. AutoRange functions create new ranges or select from existing saved ranges.

○ PRINCIPLE

PPC4 is designed to support the calibration and test of a very wide variety of test ranges in various measurement modes with a single pressure controller system.

The AutoRange function simplifies the task of selecting the Q-RPT best suited to cover a specific test range and setting controller parameters appropriately for the range. These are set automatically based on operator entry of desired measurement mode, pressure unit of measure and range full scale. The selections and default settings made by AutoRange are summarized in Table 5.

Table 5. Settings Made by AutoRange

SETTING/SELECTION	PURPOSE	SET TO	SECTION
Unit	Set pressure unit of measure	Operator specified during AutoRange	3.2.10
Mode	Set pressure measurement mode (absolute, gauge, negative gauge)	Operator specified during AutoRange	3.2.11
Full scale	Establish span maximum	Operator specified during AutoRange	None
AutoRanged span	Basis of span based setting calculations	Absolute mode: Zero absolute to full scale Gauge mode: Zero gauge to full scale Negative gauge mode: Minus atmosphere to full scale (negative equivalent of full scale on BGxxx Q-RPT).	None
Q-RPT	Select most appropriate Q-RPT to cover range and mode and operate PPC4 and RPM4 internal valving to connect the selected Q-RPT to the TEST port(s) and shut off other Q-RPTs in the system	Absolute and negative gauge mode: Axxx Q-PRT with lowest default full scale that is greater than the AutoRange full scale Gauge mode: Q-RPT with lowest span whose full scale is greater than AutoRange full scale, Gxxx over Axxx if spans are equal.	None
Upper Limit Lower Limit	Set maximum and minimum pressure control target limits	Upper limit: 105 % of operator entered full scale pressure Lower limit: None in absolute mode, zero in gauge mode, minus atmosphere in negative gauge mode, minus equivalent of upper limit in negative gauge mode on a BGxxx Q-RPT.	3.2.21
Resolution	Set pressure display resolution	10 ppm of AutoRanged span or 1 ppm of default Q-RPT range, whichever is larger.	3.2.19
Control Mode	Select dynamic or static pressure control	Dynamic control	3.2.2
Control Parameters	Set dynamic and static control <i>Ready/Not Ready</i> control limits	Dynamic control hold limit: ± 50 ppm of AutoRanged span, 5 ppm of Q-RPT span or 0.4 ppm of controller full scale, whichever is greater Dynamic and static control stability limit: 50 ppm of AutoRanged span or 2 ppm of Q-RPT span per second, whichever is greater Static control hold limit: 1 % of AutoRanged span	3.2.2 3.2.3
Jog Step	Set jog step size	100 ppm of AutoRanged span	3.2.20
Q-RPT turn down (Premium class Q-RPTs only)	Turn down Q-RPT characterization to improve measurement uncertainty when span is reduced	See Premium Q-RPT pressure measurement specifications	1.2.2.1

Note

- AutoRanged ranges cannot have altitude units (ft, m)
- If an external Q-RPT that should be available is not being selected by AutoRange, search for Q-RPTs using use [\[AutoRange\]](#), [\[RPT Search\]](#) in the Advanced Interface or <RPT> in Basic Interface. Determine whether external Q-RPTs have been properly connected and initialized (see Section 3.2.5).
- See Table 1 for a listing of Q-RPT designators and their corresponding default ranges and Table 3 for information on Q-RPT system position identification designators.
- For PPC4 to successfully identify and initialize external RPM4s, the RPM4 COM1 port settings must be:

Baud rate: between 1,200 and 19,200
 Parity: Even
 Data bits: 7
 Stop bits: 1

- If PPC4 is not able to establish communications with RPM4s and their Q-RPTs, check that the RPM4 COM1 port setting conform to the requirements above. If the COM1 port settings are correct, check that the correct communications cable is being used (standard pin-to-pin DB-9M to DB-9F RS232) and is connected to the correct communications ports.

PPC4 COM2 > RPM4 COM1

- See the RPM4 Operation and Maintenance Manual for additional information on RPM4 RS232 communications and COM port settings.
- When an RPM4 is initialized as an external device to a PPC4 pressure controller, the RPM4 front panel keypad is locked out and the second line of the display becomes:
 - <PPC EXT DEV: IDLE> (if RPM4 is initialized by PPC4 but not currently in use)
 - <PPC EXT DEV: ACTIVE> (if RPM4 is initialized by PPC4 and is currently in use)
- After using an RPM4 as an external device for a PPC4, cycle power to return to the previous RPM4 settings, restore front keypad capability and return to the normal Main Run Screen.
- The PPC4 utility sensor (luH) cannot be AutoRanged.
- The BA100K Q-RPT cannot be AutoRanged.

⚠ Caution

- Before operating PPC4 with external Q-RPTs, check carefully that the Q-RPT TEST(+) ports are connected to the PPC4 TEST(+) port. If the external Q-RPTs are NOT connected to the PPC4 TEST(+) port, they will not measure the pressure generated by PPC4 and PPC4 may reach a pressure higher than the target pressure before its watchdog function recognizes that the external RPT is not connected.
- RPM4 with Q-RPT full scale spans below 14 MPa have SDS self defense system to isolate and protect the Q-RPTs. If an external RPM4 SDS pressure rating is less than the PPC4 maximum pressure then a warning will be displayed on the PPC4 front panel when the RPM4 is detected. In addition, AutoRanged ranges greater than the SDS rating are not allowed (see Sections 3.2.5, 6.5.43.2.8). In order to create

AutoRanged ranges or generate pressures above the SDS pressure rating the RPM4 must be disconnected or the RPM4 SDS must be upgraded to a higher pressure rating. Upgrades may be done at the DH Instruments service center (see Table 36).

○ OPERATION

For Basic Interface see Section 4.5.10.

For Advanced Interface see Section 5.7.1.

3.2.9 Range

○ PURPOSE

To view and/or change the active pressure measurement range and associated settings.

Note

Range selects from existing ranges in the Basic Interface and saves current AutoRanged Ranges. See AutoRange to create ranges (see Section 3.2.8) or to select Ranges in the Advanced Interface (see Section 5.7.1).

○ PRINCIPLE

A PPC4 range is defined as a pressure span and associated settings (see Section 3.2.8).

A PPC4 may have multiple ranges. Each Q-RPT (and the utility sensor if present) available to the PPC4 system has a default range which is its maximum full scale. Additional ranges, lower than the Q-RPT's full scale, may also be created using AutoRange (see Section 3.2.8). Ranges created using AutoRange may be saved with all their settings for reactivation (see Section 5.7.1 for the Advanced Interface and Section 4.4.1.1 for the Basic Interface).

Range allows the available PPC4 pressure ranges to be viewed and selected, including automated switching of both internal and external Q-RPTs when necessary.

Note

- **Range full scale limits are given in the pressure unit that is currently active for that range. Change the active unit to display the range limits in a different unit.**
- **Many PPC4 settings and functions are range specific. See Table 4 for identification of range specific settings.**
- **To protect against overpressure situations and for maximum measurement performance, the active range can only be changed when the system is vented. When prompted by the PPC4,  causes PPC4 to vent and then complete the range change.**
- **Before operating PPC4 with external Q-RPTs, check carefully that the external Q-RPT TEST(+) port is connected to the PPC4 TEST(+) port. If the external Q-RPT is NOT connected to the PPC4 TEST(+) port, it will not measure the pressure generated by PPC4 and PPC4 may reach a pressure higher than the target pressure before its watchdog function recognizes that the external Q-RPT is not connected.**

3.2.10 Unit

○ PURPOSE

To select the unit of pressure in which PPC4 displays pressure values.

Note

For information on selecting the measurement mode (absolute, gauge, negative gauge), see Section 3.2.11.

○ PRINCIPLE

PPC4 allows the unit of measure in which pressure values are displayed to be changed. PPC4 supports 18 predefined pressure units of measure as well as up to five user defined units. See Table 35, Section 9.2.1, for a listing of the available units of measure and the conversion factors used by PPC4.

User defined unit definitions specify the number of user units per Pascal (Pa). 1 kiloPascal (kPa), for example, is specified by 0.001 units/Pa.

Note

- The pressure measurement unit selected is range specific. When in a given range, all functions and settings are represented in the current measurement unit for that range. However, certain internal and/or metrological functions (e.g., Q-RPT calibration coefficients) are always represented in Pa regardless of the active range unit of measure.
- When the active unit is an altitude unit, the range and upper limit indications are in kPa if the unit is meters (m) and psi if the unit is feet (ft).
- If the pressure unit selected is a water column (inches, millimeters, meters) the reference temperature for water density must be specified. In the Advanced User Interface, the temperature is included as part of the unit name, such as mmH2O@4C. In the Basic Interface, the temperature is specified in a secondary screen. For remote selections in both Basic and Advanced Interfaces the temperature is assumed to be 20 °C unless specified in the Unit remote command (see Section 6.5.4).
- In the Basic Interface, the default pressure units of measure available under the <Unit> function depend on whether the PPC4 has been set up as an SI or US version (indicated by SI or US at bottom right of introduction screen). The choice of six units available under the <Unit> function can be customized from a wider selection by the user (see Section 4.5.6). The units available can be reset to default by reset (see Section 3.2.25.2).

○ OPERATION

For Basic Interface see Sections 4.5.13 and 4.5.6.

For Advanced Interface see Section 5.7.6.1.

3.2.11 Measurement Mode

○ PURPOSE

To set the measurement mode (absolute, gauge or negative gauge) for the active range.

○ PRINCIPLE

PPC4 supports simple, one-step switching between up to three different measurement modes:

Absolute Measures pressure relative to vacuum (zero is hard vacuum). Range is from zero absolute to full scale.

- Gauge** Measures pressure relative to atmosphere (zero is ambient pressure). Range is from zero gauge to full scale, full scale must be greater than zero.
- Negative gauge** Measures pressure relative to atmosphere (zero is ambient pressure). Values are positive and negative, with ranges from negative one atmosphere to positive full scale. With a BGxxx Q-RPT, negative full scale is the negative equivalent of positive full scale.

Which measurement modes are available depends on the type(s) of Q-RPT available. There are three Q-RPT types:

- Axxx** Q-RPTs with designators starting with “A” measure pressure relative to a sealed vacuum reference and are intrinsically absolute. Axxx Q-RPTs support measurement in absolute, gauge and negative gauge modes. Gauge and negative gauge modes are accomplished by PPC4’s automated offsetting of atmospheric pressure and dynamic compensation for atmospheric pressure changes between offsets using an on-board barometer (see Section 3.2.4). Access to absolute and negative gauge operation can be turned OFF if these modes are not used (see Section 7.2.5).
- Gxxx** Q-RPTs with designators starting with “G” measure positive pressure relative to the **TEST(-)** port that is connected to atmosphere. Gxxx Q-RPTs support measurement in gauge mode only.
- BGxxx** Q-RPTs with designators starting with “BG” measure positive and negative pressure relative to the **TEST(-)** port that is connected to atmosphere. BGxxx Q-RPTs support measurement in gauge and negative gauge modes.

When changing measurement modes for a range, if the full scale of the range is 700 kPa (100 psi) or greater, the full scale is the same in both absolute and gauge modes. If the full scale is less than 700 kPa (100 psi), the gauge mode full scale is 100 kPa (14.5 psi) lower than the absolute mode full scale. Gauge and negative gauge mode, when available, have the same full scale.

Note

- **Certain PPC4 settings, including AutoZ ON/OFF (see Section 3.2.22) are range AND measurement mode specific. See Table 4 for a listing of settings and what they are specific to.**
- **Absolute and negative gauge modes on an Axxx Q-RPT can be turned OFF in the calibration function (see Section 7.2.5). When absolute and negative gauge mode are turned OFF for an Axxx Q-RPT, only gauge mode can be activated.**

○ OPERATION

For Basic Interface see Section 4.5.15.

For Advanced Interface see Section 5.7.6.2.

3.2.12 Set Pressure Automatically

○ PURPOSE

To use the automated pressure control functions of PPC4 to set and maintain target pressure values. **SET P** opens the target screen to initiate the sequence.

Note

- A target pressure entry that exceeds the current upper limit (see Section 3.2.21) or that is out of range will not be accepted as the target value.
- If PPC4 is unable to control pressure or appears to control pressure poorly, see Section 8 to troubleshoot.
- For PPC4 to set pressures under atmosphere and/or to reliably set pressures under 20 kPa (3 psi) gauge other than zero gauge, a vacuum pump must be connected to the EXHAUST port (see Section 2.3.5) and PPC4 must be set up for control using a vacuum reference (see Section 3.2.27.1). Setting zero gauge pressure does not require a vacuum.
- The ▲ and ▼ direct pressure control keys can be used while controlling to jog the pressure control target value up or down by the jog step value (see Section 3.2.20). These keys also jog the target value when in the ENTER target value screen.
- Due to the manner in which PPC4 handles an automated pressure command for zero in absolute pressure measurement mode, a *Ready* condition can occur at a pressure well outside of the hold limit. When setting zero in absolute measurement mode, the *Ready* condition should NOT be interpreted as meaning that the pressure is zero within the hold limit. *Ready* is an indication that the rate of change of pressure inside PPC4 has reached the current stability limit. The current pressure measured by PPC4, not zero, should be used as the value of pressure applied to the device or system under test.
- When PPC4 is given a command to set zero in absolute measurement mode, the rate of change of pressure will decrease as the pressure decreases and the rate will eventually be near zero when the vacuum pump has pulled down the pressure in the PPC4 and the test volume as far as possible. To make best use of the *Ready/Not Ready* indication when setting zero in absolute measurement mode, set the stability limit (see Section 3.2.3) to a value that represents the rate of change of pressure expected when the vacuum pump connected to the EXHAUST port has reduced pressure as far as possible.

○ OPERATION

For Basic Interface, see Section 4.2.1.

For Advanced Interface, see Section 5.5.1.

3.2.13 Control

○ PURPOSE

To set the automated pressure control mode for the active range, customize control parameters, activate default control parameters.

○ PRINCIPLE

The Control function allows the active control mode for the current range to be set to either dynamic or static. The control mode set is specific to the active range and is saved with that range when ranges are changed. For a complete description of the operation and purpose of static and dynamic control modes see Section 3.2.2.

When a control mode is selected using the Control function, Control parameters are automatically set to default values for the active range (see Table 6 for definition of PPC4 default control parameters). The default control parameters have been determined to be

most suitable for the typical user to operate within PPC4 pressure control and measurement specifications. Each PPC4 default range has default control parameters and AutoRange automatically sets control parameters appropriate for the AutoRange range.

Control mode parameters can be viewed and customized in the Control function (see Section 5.7.8 in the Advanced Interface and Section 4.4.5 in the Basic Interface). Customizing the hold and/or stability control parameters changes the conditions required for a *Ready* condition to occur (see Section 3.2.3). This can be used to increase control speed (reduce time to *Ready*), usually by decreasing control precision, or to increase precision which usually decreases control speed. For example, changing the dynamic pressure control hold limit from its default value of ± 50 ppm of the active range to ± 100 ppm of the active range will decrease the time required to set a pressure since the limit within which the pressure must be set has increased. However, it will also increase the maximum possible control error when *Ready* is indicated.

Table 6. Default Pressure Control Parameters

	STATIC MODE	DYNAMIC MODE
HOLD LIMIT	$\pm 1\%$ of range span	± 50 ppm of range span, 5 ppm of Q-RPT span or 0.4 ppm of controller span, whichever is greater
STABILITY LIMIT	50 ppm of range span or 2 ppm of Q-RPT span, per second, whichever is greater	50 ppm of range span or 2 ppm of Q-RPT span, per second, whichever is greater

○ OPERATION

For Basic Interface, see Section 4.4.5.

For Advanced Interface, see Section 5.7.8.

3.2.14 Vent

○ PURPOSE

The **VENT** control key activates a sequence to bring the test pressure to atmosphere.

○ PRINCIPLE

The Vent sequence controls the pressure to near atmospheric pressure then opens the system vent valve (see Figure 32). In addition to bringing the PPC4 test pressure to atmospheric pressure, the Vent sequence also opens the Q-RPT bypass valve for Gxxx and BGxxx Q-RPTs and, after a delay, closes the control bypass valve to minimize consumption of supply gas through the control circuit (See. Figure 31) During the Vent sequence the RED Vent LED is blinking. Once the RED Vent LED is lighted and steady and the *Ready/Not Ready* indicator becomes GREEN then the system is fully vented.

○ OPERATION

For Basic Interface, see Section 4.2.2.

For Advanced Interface, see Section 5.5.3.

3.2.15 AutoTest

○ PURPOSE

To execute a programmed sequence of automated pressure control target values.

Note

AutoTest is available with the Advanced User Interface only.

○ PRINCIPLE

The AutoTest function is intended to facilitate the execution of a series of pressure control target values such as when PPC4 is used to run a calibration sequence on a device or system being tested.

There are three sequence choices for AutoTest:

Exercise **Cycle the Test Pressure** between atmosphere or vacuum and a maximum target pressure such as when exercising a UUT prior to calibration.

The information to the right of **Exercise**: in the AutoTest menu is the last executed exercise sequence, pressure range and number of cycles.

Quick Test Allows quick definition and execution of a sequence **in the current range and using all of the current settings** (pressure unit of measure, measurement mode, control mode, control settings, display resolution).

The information to the right of **Quick Test**: in the AutoTest menu is the step size and direction for the last executed Quick Test.

Advanced Test **AutoRanges PPC4 based on the full scale and tolerance of a device under test**, prompts the user through the increments of a calibration sequence and logs calibration data. The Advanced Test function allows for the pressure at each target point to be adjusted so that the device under test reads a cardinal target pressure point. This is particularly useful when calibrating analog gauges.

The information to the right of **Advanced Test**: in the AutoTest menu is the number of saved tests available for selection.

In both the Quick Test and the Advanced Test, the PPC4 records the value of the PPC4 pressure at the time **ENTER** is used to advance to the next test point. Following the completion of the test the PPC4 values for all of the test points are displayed in a list. If the user is calibrating an analogue device, such as a gauge, the user can adjust the PPC4 pressure to set cardinal points on the analogue device before advancing to the next pressure. If this is done, the list of pressures at the conclusion of the test is the list of PPC4 pressures corresponding to the analogue cardinal points.

○ OPERATION

AutoTest is not available with the Basic Interface.

For Advanced Interface see Section 5.7.2.

3.2.16 Head

○ PURPOSE

To cause a pressure fluid head correction to be added or subtracted to the pressure measured by the PPC4 reference pressure transducer in order to predict the pressure at a height other than the PPC4's reference level.

○ PRINCIPLE

PPC4 measures gauge or absolute pressure at the height of the rear panel **TEST(+)** port. Frequently, when performing a calibration or test, the device or system under test is at a different height than the PPC4's **TEST(+)** port. This difference in height, frequently called **head**, can cause a significant difference between the pressure measured by the PPC4 at its **TEST** port height and the pressure actually applied to the device under test which is at a different height. In this case, it is useful to make a head correction to the pressure measured by the PPC4 in order to predict the pressure actually applied at a different height.

PPC4 can calculate **head** pressures for nitrogen, helium and air as the test gas over its working pressure range. The HEAD function allows the height difference to be specified and causes the resulting head pressure to be added to the pressure measured at the **TEST** port.

The reference height of the PPC4 pressure measurement is the middle of the PPC4 **TEST** port. The head height should be entered as a positive value if the device or system under test is higher than the PPC4 and negative if it is lower.



Note

- **Use of the Head function to ensure in tolerance measurements is most important in low absolute pressure ranges. Specifying the head height within ± 3 in. (7.5 cm) is adequate to ensure that, even in the worst case, the uncertainty on the head correction will be insignificant relative to the tolerance on the measurement.**
- **The Head function is NOT range specific. The Head On or Off status remains the same as ranges are changed. Edits made to the head settings are independent of active range or Q-RPT.**
- **In the PPC4 Basic Interface, when a head correction is being applied, it is indicated by <h> in the top line of the Main Run Screen (see Section 4.1). The <h> is not shown when the head correction is zero.**
- **In the PPC4 Advanced User Interface, the head height and fluid are shown beside **Head:** on the Main Run Screen (see Section 5.1).**
- **When using external Q-RPTs in RPM4, it is recommended that the RPM4 head height be adjusted to the reference level of the PPC4 before connecting the RPM4. Then, the normal PPC4 reference level to UUT head corrections can be made for all the Q-RPTs, whether internal or external to PPC4.**

○ OPERATION

For Basic Interface see Section 4.5.16.

For Advanced Interface see Section 5.7.6.3.

3.2.17 Purge

○ PURPOSE

To execute the PPC4 test system Purge function using the optional Self Purging Liquid Trap (SPLT). Purge is used to collect and exhaust liquid contaminants from the device or system under test before they reach the PPC4.

○ PRINCIPLE

PPC4 is designed to precisely set, control and measure gas pressure. Liquid contamination of the PPC4 internal pressure control module and/or the Q-RPT module can cause poor pressure control and interfere with pressure measurement. Liquid contaminants that may be present in test devices or systems that are connected to the PPC4 **TEST(+)** port are likely to make their way back to PPC4's internal pneumatic system as the test device or system is pressurized and depressurized by PPC4. To every extent possible, only clean hoses and tubing should be used to connect PPC4 to test devices or systems and those devices and systems should be free of liquid contaminants. However, in the event that PPC4 must be used to test devices or systems that may contain small amounts of liquid contaminants, a Self Purging Liquid Trap (SPLT) accessory supported by the Purge function is available.

Execution of the PURGE function is automated and proceeds as follows:

- ❶ If current pressure is greater than 700 kPa (100 psi) gauge, pressure is controlled down to less than 700 kPa (100 psi) gauge.
- ❷ Pressure control stops and a 5 second wait occurs.
- ❸ SPLT exhaust valve is opened.
- ❹ PPC4 waits until pressure is less than 20 kPa (3 psi) gauge or 110 kPa (16 psi) absolute.
- ❺ PPC4 internal vent valve is opened with the SPLT exhaust valve left open.

Note

- The Purge function makes use of the PPC4 valve driver option. Valve driver number 8 is used to actuate the SPLT exhaust valve. When making use of valve drivers, note that if the Purge function is enabled, valve driver number 8 will be actuated independently of valve driver commands. See Section 3.2.23.
- For the Purge function to execute an optional Self Purging Liquid Trap (SPLT) must be installed in the test line (see Section 2.3.7.1) and the function must have been enabled. To enable with the Basic Interface: <Spec>, <Internal>, <Purge> from the Main Menu (see Section 4.5.7.4). To enable with the Advanced Interface: [\[Settings\]](#), <Internal>, [Purge](#) (see Section 5.7.12.3).
- **ESC** at any time during execution of the purge routine causes the purge function to abort and returns to the Main Run Screen.
- The internal volume of the SPLT is about 20 cc. The SPLT will not operate effectively if the volume of liquid contaminants collected is greater than about 10 cc. The SPLT is designed to protect the PPC4 only against residual liquid contamination. Even if an SPLT is being used, precautions should be taken to reduce potential liquid contamination from the device or system under test as much as possible before making the connection to the PPC4 TEST(+) port.
- Do not plug the SPLT exhaust valve. The purge routine can not be completed with the SPLT exhaust valve plugged and the SPLT's protective function will not be effective.
- If the SPLT is electrically connected to the PPC4, its exhaust valve will always be open when the PPC4 vent valve is open. If desired, it may be closed manually using the Driver function (see Section 5.7.4 in the Advanced Interface or Section 4.4.6 in the Basic Interface).

○ OPERATION

For Basic Interface operation, see Section 4.5.17.

For Advanced Interface operation, see Section 5.7.3.1.

3.2.18 Leak Test

○ PURPOSE

To run an automated leak check routine that determines the leak rate of the system connected to the PPC4 **TEST(+)** port.

○ PRINCIPLE

Leaks in the system connected to PPC4's **TEST(+)** port can cause differences between the pressure measured by the PPC4 Q-RPTs and pressure in other parts of the test system. A large leak can cause the PPC4 to be unable to set and control pressures reliably. The LEAK CHECK function is provided as a means of checking and quantifying the leaks that may be present in the system.

The principle of the LEAK CHECK function is the measurement of the natural decrease or increase of pressure in a fixed volume over time. The LEAK CHECK function allows a leak check time to be set. The total pressure change and the average rate of change over the leak check time are calculated and displayed.

Note

- **Changing the pressure in a test system causes adiabatic temperature changes in the gas that need to dissipate before a valid leak measurement can be made. In general, a 30 second to 1 minute wait before running a leak check is adequate to allow the adiabatic temperature change to dissipate and valid leak measurements to be made. However, stabilization time may be much longer with larger volumes, higher pressures or with liquid test media.**
- **As a general rule, the maximum acceptable leak rate for optimal PPC4 automated pressure control operation and to ensure in tolerance measurements with default pressure control parameters is 0.5 % of current range span/minute.**
- **Leak check is range specific in the sense that leak check is run using the active range. However, only one set of leak check results is maintained in memory and each leak test completed overwrites the memory. View leak check always shows the results of the last leak check run regardless of the range that is now active. The results screen includes the range indicator to indicate the range in which the leak check was run.**

○ OPERATION

For Basic Interface see Section 4.5.11.

For Advanced Interface see Section 5.7.3.2.

3.2.19 Resolution

○ PURPOSE

To set the resolution with which measured pressures and other pressure indications and settings are displayed.

○ PRINCIPLE

The resolution with which PPC4 displays pressure values can be adjusted. This feature can be used to reduce the resolution when lower precision measurements are being made and excess resolution might confuse or distract the operator.

The resolution setting determines the number of digits with which pressure is displayed. The resolution is calculated based on the full scale of the range and then rounded to the

furthest digit to the right. For example, resolution of 0.001 % on a range of 150 kPa is $150 \times 0.001 \% = 0.0015$ which is rounded down to 0.001 kPa.

Note

- **Default resolution is 10 ppm of active range span. Resolution is set automatically by AutoRange (see Section 3.2.8).**
- **The resolution setting is range specific. A resolution setting made in one range does NOT affect other ranges.**
- **The measured pressure resolution is fixed for altitude units at 1 m in meters and 1 ft in feet.**
- **The maximum resolution setting is limited in AutoRange ranges that are less than 10% of the Q-RPT default full scale.**
- **The maximum resolution setting when using a utility sensor is 0.001% of utility sensor span.**

○ OPERATION

For Basic Interface, see Section 4.4.2.

For Advanced Interface, see Section 5.7.6.4.

3.2.20 Jog

○ PURPOSE

Adjust the nominal change in pressure caused by using the jog direct pressure control keys (▲ and ▼ for Advanced Interface, ▲ and ▼ for Basic Interface).

○ PRINCIPLE

The jog direct pressure control keys, ▲ and ▼, increase or decrease pressure by a nominal amount each time they are pressed. If pressure control is NOT active, pressing the jog key causes an up or down slow pressure ramp. If pressure control is active, the jog key causes the pressure control target value to be changed by the amount of the jog step.

Note

- **The default jog step is 100 ppm of active range span. The maximum jog step is 5 % of active range span. Jog step value is set automatically by AutoRange (See Section 3.2.8).**
- **The jog step setting is range specific. A jog step setting made in one range does NOT affect other ranges.**

○ OPERATION

For Basic Interface, see Section 4.4.3.

For Advanced Interface, see Section 5.7.8.2.1.

3.2.21 Pressure Limits

○ PURPOSE

To set the upper and lower limit pressure value for a pressure range and measurement mode.

○ PRINCIPLE

The Upper Limit function allows the setting of a maximum pressure not to be exceeded when using a specific range and measurement mode. Absolute and gauge measurement modes

(see Section 3.2.11) have their own, specific limits. Negative gauge mode and the BA100K Q-RPT also have a lower limit.

Automated pressure control targets greater than the upper limit or lower than the lower limit are not accepted. When the pressure measured by PPC4 exceeds the upper limit or lower limit, automated or direct manual pressure control is aborted and an intermittent warning beep sounds.

The Upper Limit most often protects the device or system connected to the PPC4 **TEST(+)** port from accidental overpressure.

Note

The default upper limit is 105 % of AutoRanged span or 102 % of Q-RPT default (maximum) range, whichever is lower. The default lower limit is - ATM, except with a BGxxx Q-RPT in which the default lower limit is the negative equivalent of the upper limit. The default lower limit of a BA100K is 66 kPa (9.6 psi).

⚠ Caution

Upper limit values are specific to each range and measurement mode. Be careful not to assume that the upper limit set in one measurement mode will apply to the other.

For example, if 150 kPa is selected as the upper limit in gauge mode, the upper limit will not be 150 kPa in negative gauge mode of the same range.

○ OPERATION

For Basic Interface, see Section 4.4.4.

For Advanced Interface, see Section 5.7.8.1.

3.2.21.1 Over Pressure Function

In addition to the UL function, PPC4 has an over pressure function.

The over pressure function executes when a Q-RPT measures a pressure that is 104 % of its default span or a utility sensor measures a pressure that is 110 % of its default span. BG15K Q-RPTs also have a negative over pressure limit. The BG15K Q-RPT negative over pressure limit is - 17.5 kPa (- 2.3 psi).

When PPC4 is using an external Q-RPT in an RPM4, the PPC4 utility sensor or Hi Q-RPT acts as a watchdog. If the watchdog measures a pressure greater than the maximum pressure of the active external Q-RPT, PPC4 executes the overpressure function.

The over pressure function causes all pressure control to be interrupted and disabled, changes the active range to the default range of the Internal, Hi (IH) Q-RPT or utility sensor and causes the measured pressure display to flash. If the Q-RPT is a Gxxx or BGxxx, the **TEST(+)/TEST(-)** bypass valve is opened. The overpressure function also logs the time and date of the overpressure condition in both user and factory logs to assist in incident diagnosis (see Section 3.2.27.5).

To recover from an overpressure condition, correct the overpressure condition and cycle PPC4 power. Be sure to correct the condition that caused the overpressure before cycling power.

Note

RPM4 has its own, independent overpressure function. When a Q-RPT on an RPM4 is active, both the PPC4 and the RPM4 may execute overpressure routines in response to an overpressure condition of the RPM4. See the RPM4 Operation and Maintenance Manual for information on the RPM4 overpressure function.

3.2.22 AutoZero (AutoZ)

○ PURPOSE

To offset the PPC4 system Q-RPTs relative to a reference value in order to compensate for possible changes in Q-RPT zero between full recalibrations.

○ PRINCIPLE

AutoZero Purpose and Principle

The main component of the change over time of PPC4 Q-RPTs is change in zero or offset, independent of span. Offsetting or “rezeroing” PPC4 Q-RPTs relative to a reference between recalibrations allows measurement uncertainty specifications to be maintained with less frequent full calibrations. The PPC4 AutoZero function (AutoZ) provides full on-board support for the rezeroing process to simplify its application by the user.

The AutoZero function uses three values:

1. **P_{std,0}**: The pressure value indicated by the AutoZ reference, the device that is acting as the reference relative to which to offset the Q-RPT.

For Axxx (absolute) Q-RPTs in **absolute measurement mode**, the pressure at which AutoZ is performed is normally atmospheric pressure and **P_{std,0}** value can be supplied by manual entry.

For Gxxx and BGxxx (gauge) Q-RPTs or Axxx (absolute) Q-RPTs in **gauge measurement mode**, **P_{std,0}** is always zero (atmospheric pressure) which is supplied by definition when the Q-RPT is vented to atmosphere.
2. **P_{u,0}**: The pressure reading of the Q-RPT, with no AutoZ offset, at the time AutoZ is performed.
3. **P_{offset,G}** and **P_{offset,A}**: The difference between the reading of the Q-RPT with no AutoZ offset (**P_{u,0}**) and the indication of the AutoZ reference (**P_{std,0}**) for gauge (**G**) or absolute measurement mode (**A**):

$$P_{\text{offset}} = P_{u,0} - P_{\text{std},0}$$

P_{offset} represents the change in zero of the Q-RPT relative to the AutoZ standard (**P_{std,0}**). The AutoZ function manages the determination, storage and application of **P_{offset}** for PPC4 system Q-RPTs in absolute and gauge measurement modes.

When the Q-RPT is calibrated, **P_{offset}** is set to zero. **P_{offset}** is then redetermined at regular intervals using the AutoZ function. The most recent value of **P_{offset}** is applied to the Q-RPT reading to correct for change in zero over time.

The AutoZ function can be turned ON and OFF. Table 8 summarizes the effect of AutoZ ON and OFF for the three Q-RPT types in different measurement modes.

AutoZ in absolute measurement mode with an Axxx Q-RPT

Q-RPTs with the designation Axxx are intrinsically absolute. They have an evacuated and sealed reference. Axxx Q-RPTs can measure absolute pressure (difference from vacuum).

In absolute measurement mode, the source of $P_{std,0}$ must be an absolute pressure, nominally atmospheric pressure, with uncertainty significantly better than that of the Q-RPT that is being AutoZeroed. For higher range Q-RPTs, this is easily accomplished with a variety of digital barometers or with a lower range Q-RPT in the PPC4 system. For lower range Q-RPTs, a piston gauge or other standard may be required to provide $P_{std,0}$ with low enough uncertainty.

When using an Axxx (absolute) Q-RPT in absolute measurement mode, with AutoZ ON, absolute pressure is calculated as:

$$P_{abs} = P_u - P_{offset,A}$$

In absolute measurement mode, execution of the AutoZ function to update the AutoZ value ($P_{offset,A}$), is initiated by the operator.

AutoZ in gauge and negative gauge measurement modes with an Axxx Q-RPT, dynamic compensation for atmospheric pressure

Q-RPTs with the designation Axxx are intrinsically absolute but they can also be used in gauge and negative gauge measurement modes (difference from atmosphere) (see Section 3.2.11). Gauge measurement mode is achieved by subtracting the value of atmospheric pressure from the Q-RPT's absolute reading using AutoZ and by dynamically compensating for changes in atmospheric pressure between opportunities for AutoZ to execute (see Section 3.2.4).

In gauge measurement modes on an Axxx Q-RPT, the value of $P_{std,0}$ is always zero gauge pressure. Zero gauge pressure, by definition, is applied to the Q-RPT when it is vented to atmosphere. In gauge measurement modes, the AutoZ routine is run automatically whenever the PPC4 is in the vented condition. This ensures regular automated updating of the $P_{offset,G}$ value corresponding to atmospheric pressure. Gauge pressure is the measured absolute pressure, P_u , minus $P_{offset,G}$.

$$P_{gauge} = P_u - P_{offset,G}$$

When AutoZ is ON, dynamic compensation for atmospheric pressure is also applied to compensate for changes in atmospheric pressure between AutoZ updates (see Section 3.2.3). The measured gauge pressure is calculated using ΔP_{atm} to correct the value of $P_{offset,G}$.

$$P_{gauge} = P_u - P_{offset,G} - \Delta P_{atm}$$

In gauge measurement mode with an Axxx RPT, execution of the AutoZ function to update the value of $P_{atm,0}$, occurs automatically whenever PPC4 is vented. Updating ΔP_{atm} occurs automatically continuously during unvented operation.

AutoZ in gauge measurement mode with a Gxxx or BGxxx Q-RPT

Q-RPTs with the designation Gxxx or BGxxx are intrinsically gauge. They have an atmospheric reference port and measure gauge pressure (difference from atmosphere).

In gauge measurement mode the value of $P_{std,0}$ is always zero gauge pressure. Zero gauge pressure, by definition, is applied to the Q-RPT when it is vented to atmosphere. In gauge measurement mode, the AutoZ routine is run automatically whenever the PPC4 is in the vented condition. This ensures the regular automated updating of the $P_{offset,G}$ value.

When using a Gxxx Q-RPT in gauge measurement mode, with AutoZ ON, gauge pressure is calculated as:

$$P_{gauge} = P_u - P_{offset,G}$$

AutoZ ON/OFF

The AutoZ function can be turned ON and OFF, separately for gauge and absolute measurement modes, see Table 7. **AutoZ ON and OFF** summarizes the effect of AutoZ ON and OFF for different Q-RPT types in absolute and gauge measurement modes.

Table 7. AutoZ ON and OFF

Q-RPT TYPE	MEASUREMENT MODE	AutoZ STATUS	P _{offset} APPLIED	ΔP _{atm} APPLIED	AutoZ ROUTINE RUNS
Axxx (or utility sensor)	Absolute	ON	YES	Not Applicable	When initiated by operator
		OFF	NO		Not available
	Gauge or negative gauge	ON	YES	YES	Automatically when PPC4 in VENT condition
		OFF		NO	
Gxxx or BGxxx	Gauge or negative gauge	ON	YES	Not Applicable	Automatically when PPC4 in VENT condition
		OFF	NO		No

Recommendations for the Use of the AutoZ Function

The AutoZ function provides a powerful and easy to use tool for improving the stability over time of PPC4 internal and external Q-RPTs and maximizing the recalibration interval by compensating for change in zero between full recalibrations. The following simple recommendations will help ensure that you use this feature to best advantage.

- In **gauge measurement** mode: Always leave AutoZ ON when operating.
- In **absolute measurement** mode: Always leave AutoZ ON when operating if the AutoZ routine has been run regularly using a valid P_{offset} reference.
- In **absolute measurement** mode: Run AutoZ at least every 30 days or when PPC4 has been exposed to temperature changes exceeding 15 °C (36 °F).
- In **absolute measurement** mode: Run AutoZ only when a reference whose measurement uncertainty is known to be significantly better than that of the Q-RPT to be AutoZeroed is available. Keep range ratios in mind when comparing uncertainty. A ± 0.01 % FS barometer is roughly 10 times better than an ± 0.01 % 1 MPa (150 psi) Q-RPT because the Q-RPT/barometer pressure ratio is 10:1. The measurement uncertainty comparison should be made at 30 % of span for both *standard class* and *premium class* Q-RPTs. Though it may not be practical, the best possible reference with which to run AutoZ in absolute measurement mode on Q-RPTs of A350K or lower, is a gas operated piston gauge (such as a **DHI PG7601**) applying a pressure near 100 kPa to the PPC4 test port. The best day to day reference is a properly calibrated **DHI RPM4** with a BA100K or A100K Q-RPT.
- In **absolute measurement mode**: Allow the PPC4 to stabilize at atmospheric pressure and ambient temperature for 10 to 15 minutes before running AutoZ.

Note

- The AutoZ function and values are Q-RPT AND measurement mode (gauge/negative gauge or absolute) specific.
- When AutoZ is run for an external Q-RPT in an RPM4, the PPC4 causes the RPM4 to run its own AutoZero routine. The RPM4 Q-RPT is then AutoZeroed as if it had been AutoZeroed independently of the PPC4.
- P_{offset} should be zero for Axxx Q-RPTs when the PPC4 is new or has just been calibrated. P_{offset} should be roughly equal to atmospheric pressure for an Axxx (absolute) Q-RPT operating in gauge mode.
- The value of P_{offset} is always displayed and entered in Pascal (Pa). Normally, in day to day operation, the value of P_{offset} is changed by running AutoZ (see Section 5.7.5.1 for Advanced Interface or Section 4.5.1.2 for Basic Interface), not by direct editing.

3.2.22.1 Edit AutoZ

Caution

The edit AutoZ function should be used with great caution as entering inappropriate values and turning ON AutoZ may result in out of tolerance measurements. In normal day to day operation, the value of the AutoZ offset, P_{offset} , should be changed using the run AutoZ function (see Section 5.7.5.1 for Advanced Interface or Section 4.5.1.2 for Basic Interface) in absolute measurement mode or automatically in gauge modes. Before editing P_{offset} , see Section 3.2.22.

Note

- The value of P_{offset} is always displayed and entered in Pascal (Pa).
- Edit and view AutoZ are not available for external Q-RPTs in gauge mode.

○ OPERATION

For Basic Interface, see Section Section 4.5.1.1.

For Advanced Interface, see Section 7.2.7.2.

3.2.22.2 Run AutoZ

Note

- Run AutoZ applies only to Axxx Q-RPTs in absolute measurement mode. In gauge and negative gauge measurement modes, AutoZ is run automatically whenever the PPC4 is in the VENT condition.
- Allow the PPC4 to stabilize at atmospheric pressure and ambient temperature for 10 to 15 minutes before running AutoZ.
- While the value of $P_{\text{std},0}$ is entered in the current pressure unit of measure, the value of P_{offset} is always in Pascal (Pa).
- If running AutoZ results in a value of P_{offset} that is greater than ± 0.005 % FS of the span of the Q-RPT that is being AutoZeroed, the Q-RPT and/or the reference used as the source of $P_{\text{std},0}$ may be out of tolerance or the AutoZ process may have been faulty. Before activating a new P_{offset} greater than ± 0.005 % FS of the active Q-RPT, check to be sure that both the Q-RPT and the reference were in good working order, properly vented to stable atmospheric pressure, at the same height, and reading in the same pressure units when AutoZ was run.
- When running AutoZ, if a HEAD correction is currently active (see Section 3.2.16), it is momentarily disabled to avoid “zeroing out” the head value.

○ OPERATION

For Basic Interface, see Section Section 4.5.1.2.

For Advanced Interface, see Section 5.7.5.1.

3.2.23 Drivers

○ PURPOSE

To control the output signals of PPC4's 8 channel, 12 V external drivers.

○ PRINCIPLE

PPC4 external drivers are available to drive peripheral equipment in a PPC4 system, for example, solenoid valves or the optional Self Purging Liquid Trap (SPLT). The driver electrical connections are available from a rear panel connector

⚠ Caution

The PPC4 PURGE function makes use of the valve driver option. Valve driver number 8 is used to actuate the SPLT exhaust valve. The SPLT exhaust valve is actuated when performing the Purge function and in the background every time the PPC4 VENT function is used. When making use of valve drivers, note that when the Purge function is enabled, valve driver number 8 will be actuated independently of user initiated valve driver commands (see Section 3.2.17).

○ OPERATION

For Basic Interface, see Section 4.4.6.

For Advanced Interface, see Section 5.7.4.

3.2.24 Remote

○ PURPOSE

To configure the PPC4 COM1, COM2, IEEE-488 (GPIB), or Ethernet communication ports. To test COM1 and COM2 communications. To select remote programming communications format. (COM1 and COM2 ports are standard on all PPC4 controllers. IEEE-488 (GPIB) and LAN ports are installed only if the appropriate communication option is purchased.)

○ PRINCIPLE

The PPC4 has two RS232 communications ports referred to as COM1 and COM2 as well as a front panel USB port. Optionally, the PPC4 may be configured with either an IEEE-488 (GPIB) port or Ethernet port. COM1, IEEE-488, and Ethernet are for communicating with a host computer (see Section 6.2). COM2 is reserved for communicating with an external device (i.e. RPM4, multimeter, etc.). Port settings can be viewed and changed using front panel commands. The USB port(s) allow connection with a PC using PPC4 Cockpit software (see Section 6.2).

The PPC4 has 3 different syntax formats available for remote program commands. **Classic** format is compatible with previous PPC products and is the default format. **Enhanced** format follows the syntax, format, and status reporting features of IEEE Std 488.2. Alternatively, a custom command format defined by the Command Interpreter Editor is selectable. The details of each are covered in Section 6.4 and the command interpreter documentation, included with the PPC4 API documentation when PPC4 Cockpit is installed (see Section 6.2.2). Select and view the active command format.

○ OPERATION

For Basic Interface see Section 4.5.2.

For Advanced Interface see Section 5.7.9.

3.2.25 Reset

○ PURPOSE

To reset various PPC4 settings to default or factory values.

○ PRINCIPLE

PPC4 stores its user definable settings in non-volatile memory. The reset menu allows the user to selectively or completely reset these settings to factory defaults. This clears out any settings that the user has made, and should be used only to restore the PPC4 to a known state. PPC4 goes through its power up sequence after any type of reset is executed.

⚠ Caution

PPC4 reset functions will change current settings to factory defaults. These may include settings vital to PPC4 operation and affecting the calibration of the quartz reference pressure transducers (Q-RPTs). Reset functions should only be used by qualified personnel with knowledge of reset consequences. Reset functions should not be used experimentally.

Reset menu choices include:

- Settings** to reset general system operating parameters (see Section 3.2.25.1).
- Units** to reset unit of measure functions (see Section 3.2.25.2).
- AutoTest** to reset AutoTest parameters and clear the AutoTest data log (see Section 3.2.25.3).
- Calibration** to reset internal calibration coefficients and modes (see Section 3.2.25.4).
- All** to reset all settings except ID and security password to factory default values (see Section 3.2.25.5).

3.2.25.1 Settings

○ PURPOSE

Sets most general operating parameters back to default values. Does not affect calibration coefficients, remote interfaces or AutoRange ranges. Reset Settings resets are itemized in Table 8.

Table 8. Reset Settings

RESET	RESULT	SEE SECTION
Unit	Returns pressure unit of measure to first of six available.	3.2.10
Mode	Returns measurement mode to the natural Q-RPT mode.	3.2.11
AutoRange	Hi Q-RPT or utility sensor default range.	3.2.8
Head	0 cm height and Nitrogen medium.	3.2.16
Control Mode	Dynamic	3.2.2
Control Limits	Default values of Hi RPT default range.	3.2.13
Upper Limit	Value of Hi RPT default range. Note: May be limited based on external Q-RPT SDS pressure rating (see Section 3.2.5).	3.2.21
Resolution	0.001% FS of Hi RPT default range.	3.2.19
Purge	Disable purge function.	3.2.17
AutoZ	AutoZ On. P _{offset} value not affected.	3.2.22

Control Reference	Auto.	3.2.27.1
Leak Check	15 second run time	3.2.18
Screen Saver	10 minutes to activation (Basic Interface) 1 hour to activation (Advanced Interface)	3.2.26.1
Key Sounds	Medium	3.2.26.2
TEST (-) Vent	Automatic.	3.2.27.5
Control Configuration	Return to default control coefficients.	7.5

○ OPERATION

For Basic Interface see Section 4.5.4.1.

For Advanced Interface see Section 5.7.5.3.1.

3.2.25.2 Units

○ PURPOSE

Resets Unit selections to factory defaults. For the Basic Interface, resets to the SI or US default selections depending on whether the PPC4 has been factory set for SI or US (see Section 3.2.10). For the Advanced Interface, clears the Favorites list.

Sets the user defined unit(s) to default names and 1.000/Pa (see Section 5.7.6.1.3 for the Advanced Interface or Section 4.5.6 for the Basic Interface).

○ OPERATION

For Basic Interface see Section 3.2.25.2

For Advanced Interface see Section 5.7.5.3.2.

3.2.25.3 AutoTest

○ PURPOSE

Resets Exercise, Quick Test and Advanced Test to default characteristics (see Section 3.2.15).

○ OPERATION

Reset AutoTest not available in Basic Interface.

For Advanced Interface see Section 5.7.5.3.3.

3.2.25.4 Calibration

○ PURPOSE

⚠ Caution

The Reset Calibration function will reset Q-RPT, utility sensor and barometer calibration coefficients and settings and reset AutoZ values to zero. This will change the PPC4 calibration and could cause it to make out of tolerance measurements.

Clears all user values affecting the calibration of Q-RPTs, utility sensor and the on-board barometer. Does not clear factory coefficients. Reset Calibration resets are itemized in Table 9.

Table 9. Reset Calibration

RESET	RESULT	SEE SECTION
All Q-RPT user calibration coefficients	PA to zero, PM to 1.	7.2.1.1, 7.2.7
Axxx Q-RPT absolute and negative gauge mode	ON.	7.2.5
Utility Sensor calibration coefficients	PA to zero, PM to 1.	7.4
On-board barometer calibration coefficients	PA to zero, PM to 1.	7.3
Calibration date	Set all dates to 19800101.	7.2.7, 7.4, 7.3
AutoZ values	All P _{offset} values to zero for absolute mode and 101325 Pa for gauge and negative gauge modes.	3.2.22
AutoZ function	ON, all Q-RPTs, all measurement modes.	3.2.22

○ OPERATION

For Basic Interface see Section 4.5.4.3.

For Advanced Interface see Section 5.7.5.3.4.

3.2.25.5 All

○ PURPOSE

Caution

The Reset - All function clears and deletes large amounts of user defined information including critical calibration data.

Combines all resets in one global reset command that clears the entire user section of non-volatile memory returning PPC4 to the “as delivered” condition except the ID function (see Section 3.2.27.1) and the security level password (see Section 3.2.26.4). Reset All resets are itemized in Table 10.

Table 10. Reset All

RESET	RESULT	SEE SECTION
Reset – Sets	All the resets of Reset – Sets	3.2.25.1
Reset – Units	All the resets of Reset - Units	3.2.25.2
Reset – AutoTest	All the resets of Reset - AutoTest	3.2.25.3
Reset – Calibration	All the resets of Reset - Calibration	3.2.25.4
Remote Interfaces	COM1, COM2, Ethernet and IEEE-488.2 interfaces to default settings.	3.2.24
Remote Communications	Remote command format to Classic.	3.2.24
Security (Level)	Low	3.2.26.4

○ OPERATION

For Basic Interface see 4.5.4.4

For Advanced Interface see Section 5.7.5.3.5.

3.2.26 Preferences

○ PURPOSE

To access a menu of PPC4 operational preferences and functions.

3.2.26.1 Screen Saver

○ PURPOSE

To adjust the PPC4's Screen Saver settings.

○ PRINCIPLE

PPC4 has a Screen Saver function which causes the display to go into a screen saving mode after receiving no front panel input for a certain amount of time. The screen saving mode and default time depends on the PPC4 local interface configuration: Basic or Advanced. The default screen saver time activates the screen saver after 10 minutes for Basic Interface and 1 hour for Advanced Interface. The screen saver activation time can be adjusted by the user or screen saving can be completely eliminated.

Note

Setting screen saver time to zero (Basic Interface) or off (Advanced Interface) eliminates the Screen Saver function so that the display permanently remains on and at full brightness.

○ OPERATION

For Basic Interface see Section 4.5.5.1.

For Advanced Interface see Section 5.7.7.1.

3.2.26.2 Sounds

○ PURPOSE

To adjust or suppress the PPC4 key press sounds.

○ PRINCIPLE

PPC4 is equipped to provide audible feedback and alarms. The sounds are used for the following indications:

Valid key press	Brief beep. Choice between three frequencies or NO sound is available (see Sections 4.5.5.2, 5.7.7.2).
Invalid key press	Descending two tone "blurb".
Leak check completed	Three two second beeps (see Section 3.2.18).
Upper or lower limit exceeded	Intermittent one second beeps (see Section 3.2.21)
External device not connected	Eight second high frequency beep (see Section 2.3.6)
Pmax! (overpressure limit) exceeded	Eight second high frequency beep (see Section 3.2.21.1).

○ OPERATION

For Basic Interface see Section 4.5.5.2.

For Advanced Interface see Section 5.7.7.2.

3.2.26.3 Time

○ PURPOSE

To view and edit the PPC4 internal time and date settings.

Note

- **The PPC4 date and time are set to United States Mountain Standard Time in the final test and inspection process at the factory. If desired, use the TIME and DATE functions to set your local time and date.**
- **The PPC4 has an internal real time clock that is used for date and time stamping calibrations and internal logs.**

○ OPERATION

For Basic Interface see Section 4.5.5.3.

For Advanced Interface see Section 5.7.7.3.

3.2.26.4 Language

○ PURPOSE

To specify the language for PPC4 Advanced Interface display, headings, menus and screens.

Note

- **The language selection affects to headings, field names and on-screen messages. Numeric displays, including pressure units, buttons and DHI trademarked terms, such as AutoRange, are always in English.**
- **Remote commands and their responses are always in English, regardless of language setting.**

○ OPERATION

Languages other than English are not available.

3.2.26.5 Security

○ PURPOSE

To set user protection levels to restrict access to certain functions and to edit the password required for changing user levels.

○ PRINCIPLE

PPC4's front panel user interface provides the means to access all PPC4 user defined data, settings and functions including calibration data. Inadvertent, uninformed or unauthorized altering or deleting of data, settings and functions could require extensive reconfiguration by the user and might cause invalid readings and behavior. For these reasons, depending upon the application in which PPC4 is being used, it may be desirable to restrict access to certain functions for certain users. The user level function provides a means of restricting access to certain functions. Four different levels of security are available.

Access to changing security levels can be left open, or be protected by a password.

Security Levels

The security levels are structured to support typical operating environments as follows:

- Off** This level is intended for use only by the system manager and/or calibration facility. It allows access and editing in all areas including critical metrological information.
- Low** Low security is designed to protect the specific metrological information and SYSTEM DIAGNOSTIC AND MAINTENANCE functions of the system against accidental alteration. It is intended for an advanced operator performing many different tasks. Low security is the default user level setting.
- High** High security is designed to protect all operating parameters. It is intended to minimize operator choices, for example to perform repeated identical calibrations under consistent conditions.

Caution

PPC4 is delivered with the security level set at low to avoid inadvertent altering of critical internal settings but with access to changing security levels unrestricted. It is recommended that the low security level be maintained at all times during normal operation. If there is a risk of unauthorized changing of the security level, changing authority should be password protected.

The security levels are structured to support typical levels of operation as shown in Table 11 and Table 12. Security levels prevent execution of the functions accessed by the key strokes marked by “*” or, in some cases with the Advanced Interface, prevent changes from being saved – thus allowing viewing of settings without allowing changes to be made:

Table 11. Security Levels, Advanced Interface

FUNCTION	LOW	HIGH
[AutoRange], [Delete Range]		•
[AutoRange], [Save Range]		•
[Settings], <Internal>, Event Log, [Clear Log]	•	•
[Settings], <Preferences>, Screen Saver		•
[Settings], <Preferences>, Sounds		•
[Settings], <Preferences>, Time		•
[Settings], <Pressure>, Pressure Unit, [Reset		•
[Settings], <Pressure>, Pressure Unit, <User Units>		•
[Settings], <Remote>		•
[Settings], Calibration, [Barometer]	•	•
[Settings], Calibration, [Hi RPT]	•	•
[Settings], Calibration, [Lo RPT]	•	•
[Tools], <Autotest>, Advanced Test, [Delete]		•
[Tools], <Autotest>, Advanced Test, [Edit]		•
[Tools], <Autotest>, Advanced Test, [New]		•
[Tools], <System>, Control Configuration		•
[Tools], <System>, Resets		•
[Tools], <System>, Run AutoZ		•

“•” indicates changes in the function/ menu are NOT allowable.

Table 12. Security Levels, Basic Interface

FUNCTION	LOW	HIGH
<Setup>, <Range>		•
<Spec>, <Log>, clear log	•	•
<Spec>, <Pref>, <ScrSvr>		•
<Spec>, <Pref>, <Sound>		•
<Spec>, <Pref>, <Time>		•
<Spec>, <Punit>		•
<Spec>, <Remote>		•
<Spec>, <Cal>	•	•
<Spec>, <Internal>, <Config>		•
<Spec>, <Reset>		•
<Spec>, <AutoZ>		•

“•” indicates the function/ menu is NOT accessible.

○ OPERATION

For Basic Interface, see Section 4.5.5.5.

For Advanced Interface, see Section 5.7.7.5.

3.2.27 Internal Functions

○ PURPOSE

To view, set, adjust, and maintain various aspects of PPC4's internal operation.

3.2.27.1 Identification

○ PURPOSE

To view or edit the PPC4 user ID and to view the PPC4 serial number.

Note

The ID can be set remotely from a computer which is more convenient than entering characters from the keyboard (see Section 6.5.4, ID command). The ID is not cleared or reset by any RESET function (see Section 3.2.25).

○ OPERATION

For Basic Interface see Section 4.5.5.4.

For Advanced Interface see Section 5.7.12.1.

3.2.27.2 Control Reference

○ PURPOSE

To specify whether PPC4 should automatically determine whether a vacuum source or atmospheric pressure is connected to its **EXHAUST** port or to manually set the **EXHAUST** port condition.

○ PRINCIPLE

The PPC4 exhaust (down) control valves and the output of the exhaust pressure regulator are connected to the PPC4 **EXHAUST** port (see Figure 31).

The response of the pressure control module, particularly when controlling pressure near and under atmospheric pressure, changes depending on whether the **EXHAUST** port is connected to a vacuum source or left open to atmosphere. To use the proper pressure control algorithms, PPC4 must know the condition of the **EXHAUST** port.

The Control Reference function allows the PPC4 to know whether its **EXHAUST** port is at vacuum or atmospheric pressure. An independent exhaust pressure sensor measures the pressure present at the port. Normally, the exhaust sensor output is used automatically by PPC4 to determine the **EXHAUST** port condition. If desired, this automatic determination can be overridden and the **EXHAUST** port condition set manually.

The Control Reference function allows setting of whether the **EXHAUST** port condition will be determined automatically using the exhaust sensor or set manually. It also allows viewing of the current status of the **EXHAUST** port.

Note

- The normal Control Reference setting is **Auto**. With this setting, the operator need not be concerned with informing the PPC4 of EXHAUST port pressure conditions as PPC4 determines the existing condition automatically. The other settings are normally used only for special applications or trouble shooting. Pressure control near and under atmospheric pressure will not operate properly if the Control Reference is not set correctly.
- The Control Reference setting is not range or control mode specific.
- The setting made in Control Reference is common across Q-RPTs and ranges as they are changed.

⚠ Caution

Before connecting a vacuum pump or vacuum source to the PPC4 EXHAUST port, see Section 2.3.5 for information on vacuum connection requirements and precautions.

○ OPERATION

For Basic Interface, see Section 4.5.7.2.

For Advanced Interface, see Section 5.7.12.2.

3.2.27.3 Barometer**○ PURPOSE**

To view the value of atmospheric pressure as measured by the PPC4 on-board barometer.

Note

There is no on-board barometer in PPC4's that have Gxxx (gauge) internal Q-RPTs only.

○ PRINCIPLE

PPC4's that include an Axxx (absolute) and/or BGxxx (bi-directional gauge) Q-RPT or a utility sensor (Auxxx) are equipped with a separate, on-board barometer. The atmospheric pressure measurements made by the on-board barometer are used for dynamic compensation of atmospheric pressure when using an Axxx Q-RPT to make gauge pressure measurements (see Section 3.2.4 and 3.2.11) and for static pressure compensation when using a BGxxx Q-RPT.

Note

- See Figure 31 for schematics showing the position of the on-board barometer in PPC4's measurement system.
- The on-board barometer is a low accuracy sensor used only for measuring small changes in atmospheric pressure over short periods of time (see Section 3.2.4) and for line pressure compensation when using a BG15K Q-RPT. PPC4 measurement uncertainty does not depend on the measurement uncertainty of the on-board barometer.

3.2.27.4 Purge

○ PURPOSE

To enable and disable the PURGE function which automate use of the optional Self Purging Liquid Trap (SPLT) (see Section 3.2.17).

⚠ Caution

When the purge function is enabled, PPC4 makes background use of valve driver channel #8 independently of user actions (see Sections 3.2.17, 3.2.23).

3.2.27.5 Log

○ PURPOSE

To view and/or clear the PPC4 event log.

○ PRINCIPLE

PPC4 records to a log each time one of the following events occurs:

- Pmax! of an internal PPC4 Q-RPT or utility sensor is exceeded (see Section 3.2.21.1).
- A memory fault occurs.

Note

Over pressure events on external Q-RPTs are not logged on the PPC4. They are logged in the RPM4's log (see the RPM4 Operation and Maintenance Manual).

○ OPERATION

For Basic Interface, see Section 4.5.9.

For Advanced Interface, see Section 5.7.12.4.

3.2.27.6 TEST (-) Vent

○ PURPOSE

To cause a PPC4 or external RPM4's Gxxx or BGxxx Q-RPT TEST (-) vent valve to stay open or closed rather than open and close automatically.

Note

This feature is active only when the active Q-RPT is a Gxxx (gauge) or BGxxx (bi-directional gauge) Q-RPT.

○ PRINCIPLE

A PPC4 or an RPM4 equipped with a Gxxx (gauge) or BGxxx (bi-directional gauge) Q-RPT has a TEST (-) vent valve in its Q-RPT module (see Figure 13).

The TEST (-) vent valve connects the **TEST (-)** port to the **VENT** port which also connects the Q-RPT and the device or system under test low side to atmosphere. In normal PPC4 operation, the TEST (-) valve is closed automatically whenever the PPC4 is performing fine pressure control to isolate the TEST (-) circuit from fluctuations in ambient pressure. The valve is opened at all other times. This ensures that the pressure in the TEST (-) circuit does not move too far away from atmospheric pressure as it might if it were permanently shut off. In normal RPM4

operation as an external device to a PPC4, the TEST (-) valve is normally closed. It is only opened when PPC4 is controlling with coarse pressure control.

Allows the TEST (-) vent valve to be set to be permanently open, permanently closed or to operate in its default automated condition. It also allows the current status of the valve to be viewed.

Note

- **The normal setting for the TEST (-) vent valve is Auto in which PPC4 automatically controls the valve based on current PPC4 operation. Manual settings should only be selected by advanced users.**
- **When the active Q-RPT is an external RPM4 Q-RPT, the TEST (-) Vent operation applies to the RPM4 Q-RPT module. The TEST (-) Vent settings made from the PPC4, apply only as long as the RPM4 is a PPC4 external device. When the RPM4 power is cycled, the RPM4 TEST (-) Vent will return to its original state.**
- **The TEST (-) Vent function setting always applies to the active Q-RPT module, whether the module is internal to PPC4 or in an external RPM4 (see the RPM4 Operation and Maintenance Manual).**

Caution

If the PPC4 detects a condition in which it determines there could be a risk of overpressure to the RPT by opening the TEST (-) Vent valve when a Manual Open is requested, a message indicating a DP overpressure risk is displayed. If this message is displayed, return to normal operation, vent the PPC4 and try again.

○ OPERATION

For Basic Interface, see Section 4.5.7.5.

For Advanced Interface, see Section 5.7.12.5.

3.2.28 Calibration

○ PURPOSE

To calibrate the PPC4 utility sensor, Hi and/or Lo Q-RPTs and adjust the on-board barometer. This function is considered part of PPC4 maintenance and is therefore covered in the maintenance section of this manual (see Sections 7.2, 7.3 and 7.4).

○ OPERATION

See Sections 7.2, 7.3 and 7.4.

3.2.29 Measurement Uncertainty

○ PURPOSE

PPC4 has the ability to configure, calculate and display the uncertainty in pressure for each controlled pressure target. The uncertainty value is available locally with the Advanced Interface and is also available remotely in the response to the PRR command for all PPC4 models (see Section 6.5.4, PRR Command). Uncertainty can be defined with or without control components (delivered or measured pressure uncertainty). Uncertainty components are explained below and default values are given in Table 13.

○ PRINCIPLE

The following uncertainty components can be configured for pressure uncertainty calculation, displayed when the PPC4 is *Ready*.

3.2.29.1 Product Uncertainty

Product uncertainty is a combination of reference, repeatability, linearity, hysteresis and slope stability uncertainties. There are three quantities that define this component. The relative uncertainty (% of reading), threshold uncertainty (% of AutoRange span) and the scaling factor for the threshold when the Q-RPT is AutoRanged. The product uncertainty is the maximum of the relative and threshold uncertainties for a given measured pressure.

Figure 8 shows the relative (% of reading) and threshold (% of span) uncertainties as well as the resulting product uncertainty for a typical Q-RPT.

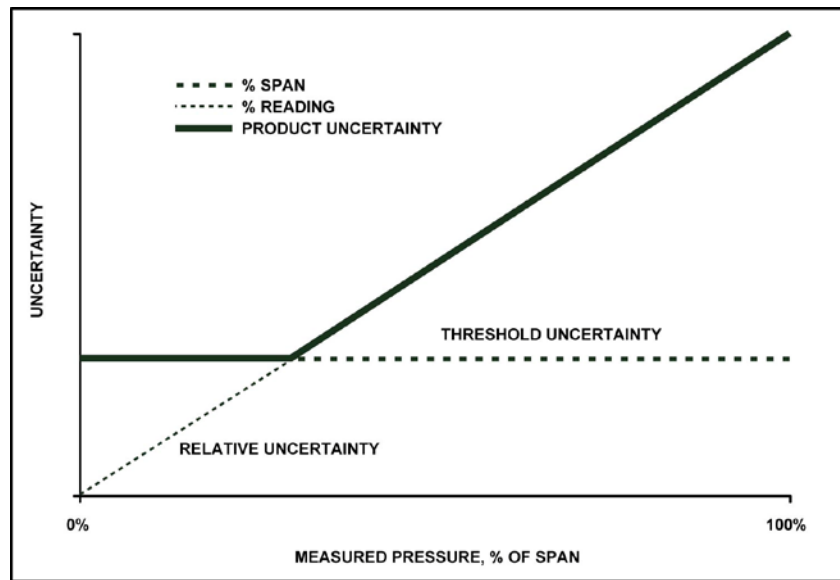

Figure 8. Product Uncertainty Illustration

3.2.29.1.1 Relative Uncertainty (% of Reading)

Relative uncertainty is entered as a percent value and is multiplied by the current pressure when *Ready* to determine the relative uncertainty.

Note

Premium and standard class Q-RPTs have a % of reading uncertainty component. For full scale standard (“f” class) Q-RPTs the % of reading is equal to zero.

3.2.29.1.2 Threshold Uncertainty (% of Span)

Threshold uncertainty is a percent of AutoRanged span. The threshold uncertainty scales down when the Q-RPT has an AutoRanged Range below the Q-RPT Default span (see Section 3.2.8).

3.2.29.1.3 Scaling Factor (Scale)

Scale specifies the lower limit for scaling for the threshold uncertainty. If a Q-RPT is AutoRanged below the scaling factor the threshold remains at the value determined by the scaling factor (see Table 13).

Example 1 - A premium Q-RPT with default coefficients is AutoRanged to 20% of the Q-RPT span. The threshold will be at 30% of 0.0024% of the Q-RPT span rather than 20% of 0.0024% of the Q-RPT span because the default scaling factor is 30% for a premium Q-RPT.

Example 2 – A standard Q-RPT with default coefficients is AutoRanged to 50% of the Q-RPT span. The threshold will be at 0.003% of the Q-RPT span rather than 50% of 0.003% of the Q-RPT span because the default scaling factor for a standard Q-RPT is 100%.

3.2.29.2 Head

Head specifies the uncertainty of head height and is specified in the active height unit (cm or in). The value is converted to pressure uncertainty with standard gravity and the calculated density of the fluid at measured pressure.

3.2.29.3 Zero Stability

Zero stability is an uncertainty based on the zero stability of the Q-RPT. Two values may be specified, one for when AutoZero is ON and one when AutoZero is OFF (see Section 3.2.22). The values are expressed in percent of Q-RPT span. Zero stability is inapplicable for Gauge Q-RPTs.

Note

The value for zero stability with AutoZero ON is equal to zero by default. If edited by the user, the value should be based on how often the AutoZero has been performed and the uncertainty of the AutoZero reference (see Section 3.2.22).

3.2.29.4 Control Uncertainty

When delivered pressure uncertainty is desired an additional uncertainty can be added to the measured pressure uncertainty. The control uncertainty calculations are based on the active control parameters (see Section 3.2.2) so it is not necessary to enter additional values.

3.2.29.4.1 Dynamic Control

The control uncertainty during dynamic control when the PPC4 is *Ready* is equal to the hold limit (see Section 3.2.2). Dynamic control uncertainty assumes that the measured pressure is equal to the target pressure with an uncertainty equal to the control hold limit.

3.2.29.4.2 Static Control

The control uncertainty during static control is defined by the stability setting and the read rate of the PPC4. Typically, the control uncertainty in static mode is negligible unless the stability limit is set abnormally high.

Note

In dynamic mode, the pressure value returned from the PR and PRR commands (see Section 6.5.4, PR and PRR Commands) is the measured pressure, not the target pressure. The control uncertainty is based on the target pressure and may be considered conservative when applied to the measured pressure. The value of control uncertainty may be considered pertinent, however, since the measured pressure can vary within the hold limit while *Ready*.

Table 13. Default Values for PPC4 Uncertainty Components

UNCERTAINTY		Q-RPT CLASS		
		FULL SCALE STANDARD F CLASS	STANDARD S CLASS	PREMIUM P CLASS
PRODUCT	READING	0.000%	0.010%	0.008%
	SPAN	0.015%	0.003%	0.0024%
	SCALE	30%, 10% for G15K, BG15K	100%	30%
HEAD		0.0 (cm or in)	0.0 (cm or in)	0.0 (cm or in)
ZERO STABILITY	AUTOZ ON*	0.000%	0.000%	0.000%
	AUTOZ OFF*	0.005%	0.005%	0.005%

*Does not apply to gauge type

3.2.29.5 Combining uncertainties

3.2.29.5.1 Measured Pressure Uncertainty

Measured pressure uncertainty is the combination of the product uncertainty and the uncertainties in pressure head and zero stability.

$$U_{meas} = 2 \times \sqrt{\left(\frac{U_{prod}}{2}\right)^2 + \left(\frac{U_{head} \times \rho_{gas} \times g_{std}}{2}\right)^2 + \left(\frac{U_{AutoZ} \times S_{QRPT}}{\sqrt{3}}\right)^2}$$

where:

U_{meas} : Measured pressure uncertainty.

U_{prod} : Product uncertainty = $Max [(U_{read} \times P_{curr}), (U_{span} \times AutoRange \text{ Span})]$ (see Figure 6).

P_{curr} : Current measured pressure.

U_{span} : Threshold uncertainty component. Allowable scaling is defined by "Scale" which specifies the extent to which the uncertainty can be downranged.

U_{head} : Uncertainty of head height measurement in cm or inches.

ρ_{gas} : Density of the test gas. In gauge mode replaced with $(\rho_{gas} - \rho_{air})$, where ρ_{air} is standard air density, 1.2 kg/m³.

g_{std} : Standard gravity 9.80665 m/s².

U_{Autoz} : Uncertainty associated with zero drift of the Q-RPT, specified with AutoZ On and separately with AutoZ Off.

S_{QRPT} : Q-RPT span.

Note

$\sqrt{3}$ is the denominator of AutoZero uncertainty for the proper reduction to $k=1$ for a rectangular distribution assigned to stability uncertainties.

3.2.29.6 Delivered Pressure Uncertainty

Delivered pressure uncertainty is measured uncertainty defined in Section 3.2.1.2.1 combined with control settings. If in dynamic control mode the additional uncertainty that is combined is equal to the hold limit. When in static control mode the uncertainty is the current pressure stability in pressure units per second multiplied by the update rate of the PPC4.

$$U_{del} = 2 \times \sqrt{\left(\frac{U_{meas}}{2}\right)^2 + \left[\left(\frac{HL}{\sqrt{3}}\right)^2 \text{ or } \left(\frac{P_{Stab} \times UpdateRate}{\sqrt{12}}\right)^2\right]}$$

where:

U_{del} : Delivered pressure uncertainty.

HL : Dynamic mode hold limit.

P_{Stab} : Current pressure stability.

$UpdateRate$: Fixed value in seconds.

Note

The denominator of the dynamic mode uncertainty component is divided by the $\sqrt{3}$ because it is considered to be a rectangular distribution. The denominator for the static control uncertainty component is divided by the $\sqrt{12}$ because it also is a rectangular distribution but represents a full width interval.

3.2.29.7 Using Values Other Than Default

The default values of the uncertainty components represent typical pressure measurement uncertainty specifications (see Section 1.2.2.1). These values are based on all Q-RPT based product lines with a confidence of 95%. This means that, taken individually, there is a good chance that the uncertainty of a given Q-PRT is lower than default. All values represented in Table 13 can be modified in the product.

⚠ Caution

There are multiple components that make up the product uncertainty portion of the uncertainty function. It is recommended that Technical Note 8050TN11 be used for guidance.

○ OPERATION

Uncertainty not available in Basic Interface, see Remote, Section 6.5.4, PRR Command

For Advanced Interface, see Section 7.2.7.3.

Notes:



4. Basic User Interface

4.1 Main Run Screen

The PPC4 Main Run Screen is its home display that is reached on power-up and from which other functions and menus are accessed. It is the very top level of all menu structures.

The Main Run Screen is where the operator works with PPC4 to set and read pressures. It provides complete information on the system's current configuration and operating status.

Figure 9 and its legend table summarize the Basic PPC4 Main Run Screen fields and their functions.

Note

- **ENTER** from the Main Run Screen to access all menu selections in the Basic Interface.
- PPC4 has a screen saver function which causes the display to dim if no key is pressed for 10 minutes. Pressing a key restores full power to the display. The screen saver time can be changed or screen saving can be completely suppressed (see Section 3.2.26.1).

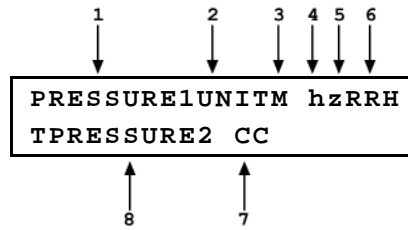

DISPLAY FIELD	NAME	PURPOSE	CONTENTS	SECTION
1. PRESSURE1	Measured pressure	Displays pressure measured by active Q-RPT	Numerical pressure value and sign	1.2.2.1 1.2.2.2 3.2.12
2. UNIT	Unit of measure	Identifies pressure unit of measure in which PRESSURE1 and PRESSURE2 are displayed	Pressure unit of measure abbreviation	3.2.10
3. M	Measurement mode	Identifies measurement mode of displayed pressure	<a>: absolute <g>: gauge or negative gauge	3.2.11
4. h	Head pressure indicator	Indicates whether a fluid head correction is applied to PRESSURE1	<h>: the fluid head is not zero <blank>: fluid head is zero	3.2.16
5. z	AutoZero indicator	Indicates whether the AutoZero function is ON or OFF	<z>: AutoZ is ON <blank>: AutoZ is OFF	3.2.22
6. RRH	Active Q-RPT position indicator	Indicates the position of the active utility sensor or Q-RPT in the PPC4 system	<IH>: Internal Hi <luH>: Internal Hi (utility sensor) <X1H>: External Hi <X1L>: External Lo	3.2.5
78. CC	Pressure control indicator	Indicates type of pressure control, whether control is currently active and whether custom control limits are in use	<D>: Control mode is dynamic <S>: Control mode is static <C> is appended to the <D> or <S> if control limits are custom Control character(s) flash if PPC4 is actively controlling	3.2.2 3.2.13
8. TPRESSURE2	Pressure information indicator	Pressure indication depending on current PPC4 function. Leading character identifies the value.	<R>: Pressure rate of change in current pressure unit/second <T>: Pressure control target <D>: Deviation from the pressure control target	3.2.12

Figure 9. Main Run Screen Display Fields

4.2 Keypad and Controls

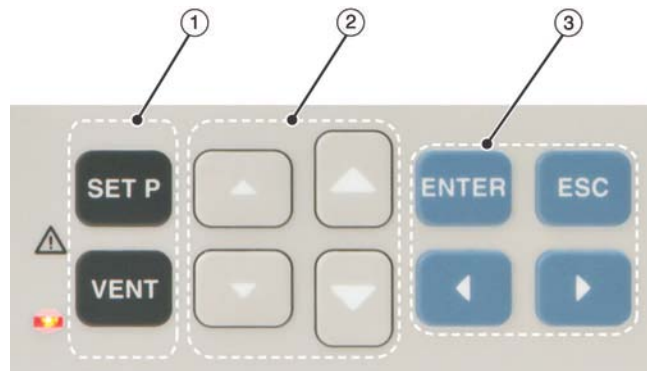

- ① THE **FUNCTION/DATA KEYS** ALLOW VERY COMMONLY USED FUNCTIONS TO BE ACCESSED DIRECTLY BY A SINGLE KEYSTROKE WHEN PRESSED FROM THE MAIN RUN SCREEN.
- ② **DIRECT PRESSURE CONTROL KEYS**
- ③ THE **MENU/DATA KEYS** PROVIDE ACCESS TO FUNCTION MENUS WHEN PRESSED FROM THE MAIN RUN SCREEN.

Figure 10. Basic PPC4 Keypad Layout

4.2.1 Set Pressure Automatically

○ PURPOSE

To use the automated pressure control functions of PPC4 to set and maintain target pressure values.

○ OPERATION

To set a pressure, **SET P** from the Main Run Screen. The display is:

1. Standard Main Run Screen first line showing measured pressure and active Q-RPT.
2. Edit field for the pressure control target pressure.

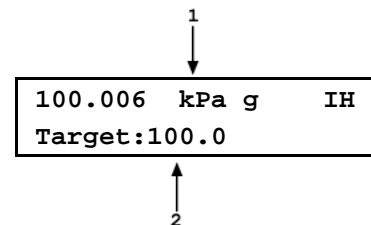

Edit the target pressure value as desired (see Section 0 for information on zero pressure commands).

Note

To edit numbers with the Basic Interface, use **◀** and **▶** for cursor position. Use **▼** and **▲** to decrease/increase digit values or enter “.” or space.

ENTER to initiate pressure control to the target pressure and return to the Main Run Screen. The Main Run Screen when pressure control is active is:

1. Standard Main Run Screen first line showing measured pressure and active Q-RPT. Shows target pressure value when condition is *Ready*.
2. Current control mode indicator. Flashes when automated pressure control is active. Character is **<D>** for dynamic control, **<S>** for static control. **<C>** is appended if custom control parameters are in use.
3. Current deviation from the target pressure (**<D>**) when in dynamic control mode and condition is *Ready*. Target pressure value (**<T>**) when controlling and condition is *Not Ready*. Pressure rate of change **<R>** when in static control mode and waiting for stability.

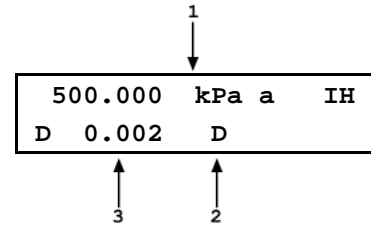

Observe the *Ready/Not Ready* indicator LED (see Section 3.2.3) for indication of when the controlled pressure has reached the target and stabilized. PPC4 continues controlling following static or dynamic control operation protocol (see Section 3.2.2) until automated pressure control is interrupted.

4.2.1.1 Interrupting Automated Pressure Control

Automated pressure control is interrupted by:

- **ESC**: Suspends control and remains in Main Run Screen. Does not vent pressure. PPC4 passively measures the pressure applied to its **TEST(+)** port.
- **Pressing any direct pressure control key other than the jog keys (see Section 3.2.20)**: Suspends control and executes direct pressure control.
- **Pressing any function key**: Suspends control and goes to the selected function. Does not vent pressure. PPC4 passively measures the pressure.
- **SET P**: Suspends control and goes to ENTER target pressure value screen. Does not vent pressure. PPC4 passively measures the pressure applied to its **TEST(+)** port.

To resume automated pressure control, **SET P** and ENTER a target pressure value.

4.2.1.2 Automated Pressure Commands for Zero Pressure

Zero in gauge mode:

A command for automated pressure control to a target value of zero when in **gauge or negative gauge** measurement mode is interpreted in the same manner as if **VENT** had been pressed (see Section 3.2.14). A *Ready* condition occurs when the vent sequence has completed, including running AutoZ if applicable (see Section 3.2.22).

Zero in absolute mode:

In response to a command for automatic pressure control to a target value of zero when in **absolute** measurement mode, PPC4 opens its down control valves fully to the **EXHAUST** port allowing the vacuum source connected to the **EXHAUST** port to pull down the pressure as far as possible (see Figure 31). The down valves stay open until another pressure command is given or control is aborted.

Note

The ultimate pressure achieved by the PPC4 and the system connected to the PPC4 **TEST(+)** depends on the vacuum pump, the pump connections, the volume connected to the **TEST(+)** port and PPC4 internal restrictions.

A *Ready* condition occurs when the pressure control stability limit is reached (see Section 3.2.3).

4.2.2 Vent

○ PURPOSE

VENT activates a sequence to bring the test pressure to atmosphere (see Section 3.2.14).

○ OPERATION

VENT causes PPC4 to control pressure to near atmospheric pressure and then open the system vent valve (see Figure 31 and Figure 32). On-going execution of the vent function is indicated by lighting a RED LED to the left of the **VENT** key. Completion of the vent process is indicated by the *Ready/Not Ready* indicator light becoming GREEN with the vent RED LED still lighted. The vent valve remains open until **VENT** is pressed again, another direct pressure control key is pressed, or an automated pressure control command is given.

4.3 Basic Interface menus

4.3.1 Main Menu Tree

Note

ENTER to access the Main Menu tree from the Main Run Screen.

MENU SELECTION	SEE SECTION
<Setup>, <Range>, <Save/Delete/Delete All>	4.4.1
<Setup>, <Res>	4.4.2
<Setup>, <Jog>	4.4.3
<Setup>, 	4.4.4
<Setup>, <Control>, <Limits>	4.4.5.1
<Setup>, <Control>, <Mode>, <Dynamic/Static>	4.4.5
<Setup>, <Drv>	4.4.6
<Spec>, <AutoZ>, <On-Off/View/Edit/Run>	4.5.1
<Spec>, <Remote>, <COM1/COM2/IEEE488/Format/RS232Test/Ethernet>	4.5.2
<Spec>, <Head>, <in/cm>	4.5.3
<Spec>, <Reset>, <Sets/Units/Cal/All>	4.5.4
<Spec>, <Pref>, <ScrSvr>	4.5.5.1
<Spec>, <Pref>, <Sound>, <None/Lo/Mid/Hi>	4.5.5.2
<Spec>, <Pref>, <Time>, <Time/Date>	4.5.5.3
<Spec>, <Pref>, <ID>, <View/Edit>	4.5.5.4
<Spec>, <Pref>, <Level>, <Change User Level/ Edit Password >	4.5.5.5
<Spec>, <Punit>, <SI/Other/Altitude/User>	4.5.6
<Spec>, <Internal>, <Config>	4.5.7.1
<Spec>, <Internal>, <Control Ref>	4.5.7.2
<Spec>, <Internal>, <Baro>	4.5.7.3
<Spec>, <Internal>, <Purge>, <Enable purge>	4.5.7.4
<Spec>, <Internal>, <Lo Vnt>	4.5.7.5
<Spec>, <Cal>, <Hi RPT>, <View/Edit>	7.2

MENU SELECTION	SEE SECTION
<Spec>, <Cal>, <Lo RPT>, <View/Edit>	7.2
<Spec>, <Cal>, <Barometer>, <View/Edit>	7.3
<Spec>, <Log>	4.5.9
<ARange>, <Abs/Gage/Neg Gage>	4.5.10
<Leak>, <Run/View>	4.5.11
<RPT>	4.5.12
<Unit>	4.5.13
<Range>	4.5.14
<Mode>, <Abs/Gage/Neg Gage>	4.5.15
<Head>	4.5.16
<Purge>	4.5.17

4.4 Menu Tree Operation

○ PURPOSE

Note

ENTER from the Main Run Screen to access all menu selections in the Basic Interface.

<Setup> accesses a menu of functions and features commonly used in setting up and using PPC4.

4.4.1 <Setup>, <Range>

○ PURPOSE

Save AutoRange ranges and associated settings for recall. Delete previously saved AutoRange ranges.

4.4.1.1 Saving An AutoRanged Range

○ OPERATION

To save a range created by AutoRange, the range must be the active range. Use AutoRange to create the range (see Sections 3.2.9 and 4.5.10) and then make any desired feature and setting adjustments.

Once the AutoRanged range is set up as desired, use <Setup>, <Range>, <Save>. The display is:

1. Indication that this is an AutoRange range to be saved.
2. Designator and position of the Q-RPT used by the range to be saved.
3. Pressure unit of measure of the range to be saved.
4. Full scale pressure of the range to be saved in gauge mode and absolute mode if available.

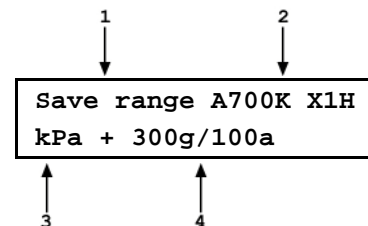

ENTER to save the range or **ESC** to return to the Main Run Screen without saving the range.

4.4.1.2 Deleting AutoRange Ranges

○ OPERATION

To delete a single saved AutoRange range, use **<Setup>**, **<Range>**, **<Delete>**. If there are any saved ranges available to delete, the display is:

1. Indication that the cursor control keys may be used to toggle through the saved ranges to select the one to be deleted.
2. Designator and position of the Q-RPT used by the range to be deleted.
3. Pressure unit of measure of the range to be deleted.
4. Full scale pressure of the range to be deleted in gauge mode and absolute mode if available.

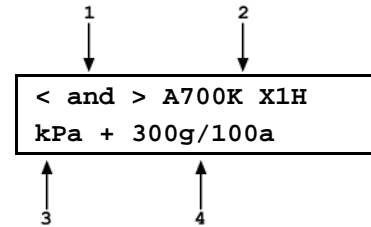

Use the cursor control keys to toggle through the ranges available to be deleted. When the desired range to be deleted is displayed, **ENTER**. If you are sure you want to delete this range, **ENTER** again in response to the **<Delete?>** query. **ESC** to return to the AutoRange screen without deleting a range.

To delete all of the saved AutoRange ranges, press **<Setup>**, **<Range>**, **<Delete All>**. If you are sure you want to delete all the ranges, respond **<Yes>** to the **<Delete all saved ranges?>** query. If not, respond **<No>**.

4.4.2 <Setup>, <Res> (Resolution)

○ PURPOSE

To set the resolution with which measured pressures and other pressure indications and settings are displayed (see Section 3.2.19).

○ OPERATION

To access the resolution function, select **<Setup>**, **<Res>**. The display is:

```
Display resltn:  IH
0.0010 %FS  < and >
```

Use the cursor control keys to set the desired level of resolution. **ENTER** to return to the Main Run Screen with the new resolution setting active or **ESC** to make no changes.

4.4.3 <Setup>, <Jog>

○ PURPOSE

Adjust the nominal change in pressure caused by using the jog direct pressure control keys (**▲** and **▼**) (see Section 3.2.20).

○ OPERATION

To access the jog step adjustment function, select **<Setup>**, **<Jog>**. The display is:

```
Jog step size:  IH
0.020 kPa
```

Edit the value of the jog step as desired. **ENTER** to return to the Main Run Screen with the new jog step size active. **ESC** to return to the Main Run Screen with no change to the jog step size.

4.4.4 <Setup>, (Upper Limit)

○ PURPOSE

To set the upper and lower limit pressure value for a pressure range and measurement mode (see Section 3.2.21).

○ OPERATION

To view or edit upper and lower limits use <Setup>, .

If the current measurement mode is absolute or gauge, there is an upper limit only. The display is:

1. Entry field for upper limit value in active pressure unit of measure and measurement mode.

Upper limit:	IH
204.000 kPa a	

↑
1

Edit the upper limit value as desired. The maximum upper limit is 105 % of AutoRange range or 102 % of default Q-RPT range, whichever is smaller. **ENTER** to return to the Main Run Screen with the new upper limit active. **ESC** to return to the Main Run Screen with no change to the upper limit.

If the current measurement mode is negative gauge or the Q-RPT is a BA100K, there is also a lower limit. The display is:

1. Entry field for upper limit value.
2. Entry field for lower limit value and active range pressure unit of measure and measurement mode indication.

Upper: 104.00	IH
Lower: -110.00 kPa g	

↓
1

↑
2

Edit the upper and lower limit values as desired. Use the cursor control keys to move between the two edit fields. The lower limit must be a negative value. **ENTER** to return to the Main Run Screen with the new upper and/or lower limit active. **ESC** to return to the Main Run Screen with no change to the limits.

When the upper or lower limit has been exceeded, the display of current pressure flashes and a buzzer sounds for 3 seconds at 2 second intervals. Reduce pressure using direct pressure control keys or an automated pressure command to return to normal operation.

Note

Upper limit values are specific to each range and measurement mode. Be careful not to assume that the upper limit set in one measurement mode will apply to the other.

For example, if you set 150 kPa as the upper limit in gauge mode, the upper limit will not be 150 kPa in negative gauge mode of the same range.

4.4.4.1 Over Pressure Function

In addition to the UL function, PPC4 has an over pressure function (see Section 3.2.21.1).

To recover from an overpressure condition, correct the overpressure condition and cycle PPC4 power. Be sure to correct the condition that caused the overpressure before cycling power.

4.4.5 <Setup>, <Control>

○ PURPOSE

To set the automated pressure control mode for the active range, customize control parameters, activate default control parameters.

○ OPERATION

To access the CONTROL function, use <Setup>, <Control>. The display is:

Dynamic	X1H
◆Limits	◆Mode

<Limits> to view or edit the current control limits (see Section 4.4.5.1).

<Mode> to change the control mode and to reset custom control parameters (see Section 4.4.5.2).

The display is:

Control Mode:	X1H
◆Dynamic	◆Static

The cursor is on the active control mode. Making a control mode selection activates the control mode, sets default control parameters and returns to the Main Run Screen. To set custom control parameters, use <Setup>, <Control>, <Limits> from the Main Run Screen (see Section 3.2.13).

4.4.5.1 <Limits> (Custom Control Parameters)

○ PURPOSE

To view active pressure control parameters and/or set custom control parameters.

○ OPERATION

To view active control parameters and/or set custom control parameters, select <Setup>, <Control>, <Limits> from the Main Run Screen. The display is:

1. Active Q-RPT designator.
2. View/edit field of hold limit value in active pressure unit of measure. Shows active hold limit.
3. Active control mode (<D> for dynamic, <S> for static).

Hold Limit:	X1H
0.05	kPa D

Edit the hold limit value if desired and **ENTER** to view the stability. The next display is:

1. Active Q-RPT designator.
2. View/edit field of stability limit value in active pressure unit of measure. Shows active stability limit.
3. Active control mode (<D> for dynamic, <S> for static).

Stability Limit:	X1H
0.05	kPa/s D

Edit the stability limit value if desired and **ENTER** to return to the Main Run Screen with the edited values active.

4.4.5.2 Turning-Off Custom Control Parameters

To return to default pressure control parameters for the active range and control mode, reselect the control mode using **<Setup>**, **<Control>**, **<Mode>** (see Section 3.2.13).

4.4.6 <Setup>, <Drv> (Drivers)

○ PURPOSE

To control the output signals of PPC4's 8 channel, 12 V external drivers (see Section 3.2.23).

○ OPERATION

To access the driver control function use **<Setup>**, **<Drv>**. The display is:

External Drivers: 1							
2	3	4	5	6	7	8	

◀ or **▶** allows navigation between valve driver numbers. **ENTER** turns that driver ON and OFF. An active driver is indicated by **<*>** immediately following the driver number.

⚠ Caution

The PPC4 PURGE function makes use of the valve driver option. Valve driver number 8 is used to actuate the SPLT exhaust valve. The SPLT exhaust valve is actuated when performing the PURGE function and in the background every time the PPC4 VENT function is used. When making use of valve drivers, note that when the PURGE function is enabled, valve driver number 8 will be actuated independently of user initiated valve driver commands (see Section 3.2.27.4).

4.5 <Spec> (Special)

Note

ENTER from the Main Run Screen to access all menu selections in the Basic Interface.

○ PURPOSE

<Spec> accesses a menu of PPC4 functions and features that are less commonly used or not normally used in regular operation.

○ OPERATION

<Spec> from the Main Menu screen to access the menu. The display is:

◆AutoZ	◆Remote	◆Head
◆Reset	◆Pref	◆Punit ↓
◆Internal	◆Cal	◆Log

Note

Some screens, such as the SPECIAL menu, go beyond the two lines provided by the display. This is indicated by a flashing arrow in the second line of the display. Press the cursor control keys to move the cursor to access the lines that are not visible.

SPECIAL menu choices include:

- <AutoZ>** Manage AutoZero function for the active Q-RPT or utility sensor (see Section 4.5.4.1).
- <Remote>** View and edit PPC4 COM port (RS232) and IEEE-488 or Ethernet interface settings (see Section 4.5.4.2).
- <Head>** Set HEAD function fluid and height unit of measure (see Section 4.5.4.3).
- <Reset>** Access PPC4's various reset functions (see Section 4.5.4.4).
- <Pref>** View and set screen saver time, keypad sound frequency, unit ID number, time/date, security protection level (see Section 4.5.5).
- <Punit>** Customize the **<Unit>** key pressure unit of selections (see Section 4.5.6).
- <Internal>** Access internal functions including control configuration, control reference, on-board barometer viewing, and purge function ON/OFF, direct control of Q-RPT Lo Vent valves (see Section 4.5.7).
- <Cal>** View and adjust PPC4 utility sensor, Q-RPT and barometer calibration coefficients (see Section 4.5.8, 7.2, 7.3 and 7.4).
- <Log>** View the PPC4 incident log (see Section 4.5.9).

4.5.1 <Spec>, <AutoZ>

○ PURPOSE

To offset the PPC4 system Q-RPTs relative to a reference value in order to compensate for possible changes in Q-RPT zero between full recalibrations (see Section 3.2.22).

○ OPERATION

To access the PPC4 AutoZ function menu use **<Spec>**, **<AutoZ>**. The display is:

1. Active Q-RPT designator.
2. Indication of active measurement mode (**abs** for absolute, **gage** for gauge and negative gauge).
3. Indication of whether AutoZ is currently ON or OFF for this Q-RPT and measurement mode.

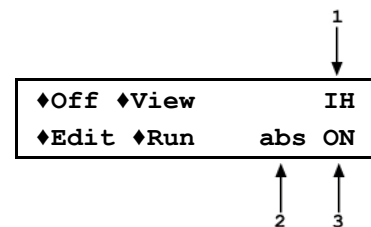

- **<Off>** (or **<On>**) to change the AutoZ status for the current Q-RPT and measurement mode from ON to OFF or vice versa.

Note

AutoZ ON is indicated by a <z> in the Main Run Screen, top line, fourth character from the right. When AutoZ is OFF, the character is blank.

- **<View>** to view the current value of P_{offset} for the active Q-RPT and measurement mode.
- **<Edit>** to edit the value of P_{offset} for the active Q-RPT and measurement mode (see Section 4.5.1.1).

- **<Run>** to run the AutoZ routine which determines and activates P_{offset} relative to $P_{std,0}$ (see Section 4.5.1.2). **<Run>** is only applicable to Axxx (absolute) Q-RPTs in absolute measurement mode. AutoZ is run automatically without operator intervention in gauge and negative gauge measurement modes whenever PPC4 is in the VENT condition (see Section 3.2.14).

4.5.1.1 Edit AutoZ

To edit the current P_{offset} value for the active Q-RPT and measurement mode, press **<Spec>**, **<AutoZ>**, **<Edit>**. The display is:

1. **<Abs>** for absolute, **<Gage>** for gauge and negative gauge.
2. Active Q-RPT for which P_{offset} is being viewed.
3. Edit field for value of P_{offset} .

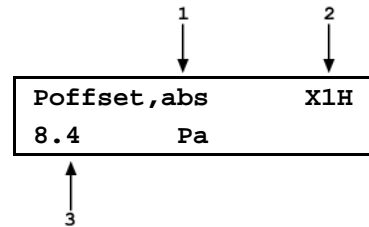

Edit P_{offset} as desired and **ENTER** to activate the new value. **ESC** to abandon changes.

4.5.1.2 Run AutoZ

Run AutoZ is the function by which the current Q-RPT reading is compared to a reference, $P_{std,0}$, at atmospheric pressure to determine a new value of P_{offset} . The value of P_{offset} is then used by AutoZ to automatically correct the Q-RPT for possible change in zero (see Section 3.2.22).

To access run AutoZ, press **<Spec>**, **<AutoZ>**, **<Run>**. If the current measurement mode is gauge, a message indicating that AutoZ cannot be run manually in gauge mode is displayed.

If the current measurement mode is absolute, the display is:

1. Real time reading (without head correction), pressure unit of measure and measurement mode of the active Q-RPT.
2. Active Q-RPT position designator.
3. Entry field for the value of $P_{std,0}$ in the current pressure unit of measure.

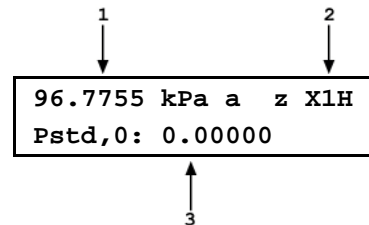

Enter the value of the AutoZ reference ($P_{std,0}$) in the same unit of measure as the top line display and **ENTER**. PPC4 logs the readings and calculates a new AutoZ offset value. The next display is:

Press **ENTER** to activate the new value of P_{offset} or **ESC** to start over with entry of a new AutoZ reference ($P_{std,0}$) value.

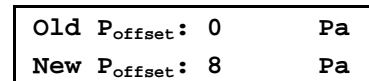

4.5.2 <Spec>, <Remote>

○ PURPOSE

To configure the PPC4 COM1, COM2 and IEEE-488 (GPIB) or Ethernet communication ports. To test COM1 and COM2 communications. To select remote programming communications format (see Sections 3.2.24 and Section 6.3.1).

○ OPERATION

To access the communications settings, select **<Spec>**, **<Remote>**.

Choice include:

<COM1>	To view and edit COM1 settings (see Section 4.5.2.1).
<COM2>	To view and edit COM2 settings (see Section 4.5.2.1).
<IEEE>	To view and edit IEEE-488 settings (see Section 4.5.2.2).
<Format>	To select remote programming command format (see Section 4.5.2.3).
<RS232test>	To run the COM1 and COM2 communications test (see Section 4.5.2.4).
<Ethernet>	To view and edit LAN (Ethernet) settings (see section 4.5.2.5).

4.5.2.1 <COM1> and <COM2>

The COMx ports can be set for specific communications settings. The settings are baud rate, parity, data bits and stop bits. The available options are:

Baud 1 200, 2 400, 4 800, 9 600, 19 200

Parity None, Odd or Even

Length 7 or 8

Stop Bit 1 or 2

The default is <2400, E, 7, 1> for both COM1 and COM2.

The user can also specify one or two termination characters as well as define these characters. These are referred to as "Term1" and "Term2". These define the characters that mark the end of commands that are sent to the PPC4. The PPC4 looks for an ASCII(13) (carriage return) to terminate a received command but responds with both an ASCII(13) (carriage return) and an ASCII(10) (line feed). There are no other options.

4.5.2.2 <IEEE-488>

The IEEE-488 port's primary address can be set from 1 to 31 in this screen. The factory default value is 10. Secondary addressing is not used or supported. This address must not conflict with the address of any other device on the same IEEE-488 bus.

The receiving terminating character must be a line feed and EOI. Carriage returns are ignored if received. The PPC4 sends a line feed and asserts the EOI line to terminate a reply. These settings are fixed to agree with IEEE Std. 488.2. If you change the address, the IEEE interface will reset (PON) and become idle.

4.5.2.3 <Format>

<Spec>, **<Remote>**, **<Format>** allows the remote program command syntax to be selected. The cursor is on the active format. Select **<Classic>** to activate the classic command format or **<Enhanced>** for the enhanced format.

Selecting a format resets the IEEE-488 interface and puts it into an idle state.

4.5.2.4 <RS232test>

The RS232 self-test is provided to check the PPC4 COM ports and the interface cable independently of an external device or computer.

If you are having difficulty communicating with PPC4 from a host computer using RS232, the RS232 self test can help establish that the PPC4 COM1 port you are trying to communicate with and the interface cable you are using are good.

To run a self test of the RS232 ports (COM1 and COM2), press **<Spec>**, **<Remote>**, **<RS232test>**.

The display prompts you to connect COM1 to COM2 using a standard pin-to-pin DB-9F to DB-9M RS232 cable (see Section 6.3.1.1).

Once the cable has been installed, **ENTER** to run the self-test. The test is first executed in the COM1→COM2 direction and then in the COM2→COM1 direction.

If the COM1→COM2 test passes: **<PASSED>** displays briefly and the test proceeds to COM2→COM1.

If COM2→COM1 passes: **<PASSED>** is displayed briefly followed by the conclusion, **<The RS232 test has PASSED>**.

If a test fails: Execution is suspended until **ENTER** is pressed.

Note

- The PPC4 RS232 test can fail for three reasons:
- The RS232 cable being used is incorrect (see Section 6.3.1.1 for information on the correct cable).
- COM1 and COM2 do NOT have the same serial communications settings and cannot communicate (see Section 4.5.2.1 to set the COM ports).
- COM1 or COM2 is defective.
- The reason for failed communications is almost always a cable or incorrect RS232 interface settings. Be sure that these are correct before concluding that a COM port is defective.

4.5.2.5 <Ethernet>

○ PURPOSE

<Spec>, **<Remote>**, **<Ethernet>** allows settings that pertain to the Ethernet connection (optional). DHCP (Dynamic Host Configuration Protocol) determines how an IP address will be provided: With DHCP "On" the IP address is provided by the LAN (Local Area Network). With DHCP "Off" the IP address is provided manually.

DHCP On, Off

Addr IP address (1xx.xxx.xxx.xxx) where x is 0-9

To enter an IP address in static mode (i.e. DHCP=Off):

▲ or **▼** to toggle between 0 and 5

▾ and **▴** to increase/decrease by 1

◀ and **▶** select which digit to edit.

ENTER to accept IP address and display the PPC4 MAC (Media Access Control) address. This value is unique to each PPC4 and is contained in the Ethernet module of the PPC4 if the Ethernet option is selected.

4.5.3 <Spec>, <Head>

○ PURPOSE

To view or change the properties of the fluid Head function (see Section 3.2.16) including the unit of measure of length for head height entry and the test gas species for density calculations.

○ OPERATION

From the Main Menu screen, press <Spec>, <Head>.

Select the desired height unit of measure and **ENTER**.

Select the type of gas that is being supplied to PPC4 and **ENTER**. The characteristics of the gas selected will be used by PPC4 in calculating head pressures.

4.5.4 <Spec>, <Reset>

○ PURPOSE

To reset various PPC4 settings to default or factory values (see Section 3.2.25).

⚠ Caution

PPC4 reset functions will change current settings to factory defaults. These may include settings vital to PPC4 operation and affecting the calibration of the quartz reference pressure transducers (Q-RPTs). Reset functions should only be used by qualified personnel with knowledge of reset consequences. Reset functions should not be used experimentally.

○ OPERATION

To access the RESET menu, press <Spec>, <Reset>.
The display is:

◆Sets	◆Units	◆Cal
◆All		

RESET menu choices include:

- <Sets> to reset general system operating parameters (see Section 4.5.4.1).
- <Units> to reset unit of measure functions (see Section 4.5.4.2).
- <Cal> to reset internal calibration coefficients and modes (see Section 4.5.4.3).
- <All> to reset all settings except ID and security password to factory default values (see Section 4.5.4.4).

4.5.4.1 <Set>

○ PURPOSE

The Reset – Sets resets are itemized in Table 8, Section 3.2.25.1.

4.5.4.2 <Units>

○ PURPOSE

The Reset – Units resets are itemized in Section Section 3.2.25.2.

4.5.4.3 <Cal>

○ PURPOSE

⚠ Caution

The Reset - Cal function will reset Q-RPT, utility sensor and barometer calibration coefficients and settings and reset AutoZ values to zero. This will change the PPC4 calibration and could cause it to make out of tolerance measurements.

The Reset – Cal resets are itemized in Table 9, Section 3.2.25.4.

4.5.4.4 <All>

○ PURPOSE

⚠ Caution

The reset - all function clears and deletes large amounts of user defined information including critical calibration data.

The Reset – All resets are itemized in Table 10, Section 3.2.25.5.

4.5.5 <Spec>, <Prefs>

○ PURPOSE

To access a menu of PPC4 operational preferences and functions.

○ OPERATION

To access the PREFS menu press <Spec>, <Pref>.
The display is:

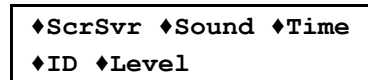

The PREFS menu includes:

- <ScrSvr> View and change the screen saver activation time (see Section 4.5.5.1).
- <Sound> View and change the key press sounds (see Section 4.5.5.2).
- <Time> View and edit the internal time and date settings (see Section 4.5.5.3).
- <ID> View the PPC4 serial number (SN) and view or edit the ID number (see Section 4.5.5.4).
- <Level> View and set user security level and password (see Section 4.5.5.5).

4.5.5.1 <ScrSvr>

○ PURPOSE

To adjust the idle time after which PPC4's SCREEN SAVER activates (see Section 3.2.26.1).

Note

Setting screen saver time to zero eliminates the SCREEN SAVER function so that the display permanently remains at full brightness.

○ OPERATION

To access the SCREEN SAVER function, use <Spec>, <Pref>, <ScrSvr>. Edit, in minutes, the idle time after which screen saver will activate to dim the screen. Set the time to zero to eliminate the SCREEN SAVER function.

4.5.5.2 <Sound>

○ PURPOSE

To adjust or suppress the PPC4 key press sound (see Section 3.2.26.2).

○ OPERATION

To access the keypad sound adjustment function use <Spec>, <Pref>, <Sound>.

<Lo>, <Mid> or <Hi> to adjust the valid key press tone frequency.

<None> to suppress the key press tone.

4.5.5.3 <Time>

○ PURPOSE

To view and edit the PPC4 internal time and date settings (see Section 3.2.26.3).

○ OPERATION

To access the TIME function use <Spec>, <Pref>, <Time>. The display is:

Edit: ♦Time ♦Date 08:32:11am 20080325
--

<Time> to edit the time. Edit hours, then minutes, then am/pm by using **ENTER** after each entry. Seconds go to zero when minutes are entered. This can be used to synchronize the time with a time standard.

<Date> to edit the date. The date must be specified in YYYYMMDD format.

4.5.5.4 <ID>

○ PURPOSE

To view or edit the PPC4 user ID and to view the PPC4 serial number (see Section 3.2.27.1).

○ OPERATION

To access the ID function use <Spec>, <Pref>, <ID>. <View> to view the current ID. <Edit> to edit the ID.

The ID has twelve characters. When the edit screen is opened, the cursor is on the first character. Numerical values can be entered directly from the keypad. In addition, the cursor control keys can be used to toggle through a list of available alpha numeric characters. Holding the key slews through the characters. Character order going up is: blank space, symbols, lower case letters, upper case letters, and numbers. After selecting a character, **ENTER** to activate it and move to the next character field.

When a character is selected the cursor moves to the next character. To leave a blank character, **ENTER** with the field for that character blank. Use this for the trailing characters if the ID being entered is less than twelve characters.

After the last of the twelve characters has been entered, the <Save ID?> option is offered. <No> to return to the ID edit screen. <Yes> to save the edited ID.

Note

The ID can be set remotely from a computer which is more convenient than entering characters from the keyboard (see Section 6.5.4, ID command). The ID is not cleared or reset by any RESET function (see Section 3.2.25).

4.5.5.5 <Level> (Security)

○ PURPOSE

To set user protection levels to restrict access to certain functions and to edit the password required for changing user levels. The security levels are structured to support typical levels of operation as shown in Table 12, Section 3.2.26.4.

○ OPERATION

PPC4 is delivered with no active password and access to the User Level menu is open. The user level is set to low. User levels can be changed freely until a password has been created.

To access the LEVEL function use <Spec>, <Pref>, <Level>. The display is:

◆Change user level
◆Edit password

<Change user level> brings up the restriction menu:

Restrictions:
◆Disable ◆Enable

The cursor is on the current restriction level. Select a different level or or **ESC** back to the Main Run Screen.

If no password is active, <Edit password> displays the user password and allows it to be edited.

Password: pppppp
0 disables password

⚠ Caution

Once a password has been entered, the user level cannot be changed without reentering the password.

Passwords can be up to six numbers in length and cannot start with a zero. If <0> is entered, the password is made inactive and the user will not be required

to enter a password to access the user level menu. This condition, with a security level of **<Lo>**, is the factory default.

If there is an active password, the PPC4 password entry screen appears. The user must enter the user defined password or the factory secondary password to proceed further:

SN: nn	XXXX
Password: pppppp	

The first field, **<nn>**, is the serial number of the PPC4, followed by a second field, **<XXXX>** a number that the PPC4 changes each time the secondary password is used. The third field, **<pppppp>** is for user entry of the normal password.

Note

The factory secondary password is available in case the user's password has been misplaced or forgotten. It can be obtained by contacting a DHI Authorized Service Center (see Table 31). The factory secondary password is different for all PPC4's and changes each time it is used.

4.5.6 <Spec>, <Punit>

○ PURPOSE

To customize the selection of pressure units of measure.

○ OPERATION

From the Main Run Screen press **<Spec>**, **<Punit>**. The display is:

1. Entry field to specify which unit position (1 – 6) of the **<Spec>**, **<Punit>** function key menu is to be changed.

1
↓

Set up unit #6	IH
----------------	----

Enter the number of the unit position that you would like to change. The display becomes:

Unit#6	◆SI	◆Other
◆Altitude	◆User	

Select the desired pressure unit category (SI units include units *based* on SI such as mmHg), then select the desired unit from the unit menu.

The units of measure available are listed in Table 14.

Table 14. Unit Function - Available Units of Measure

<SI>	<Other>	<Altitude>	<User>
<Pa>	<psi>	<feet>	
<hPa>	<psf>	<meters>	
<kPa>	<inHg>		
<MPa>	<inWa>		
<mbar>	<kcm2>		
<bar>	<Torr>		
<mmHg>	<mTor>		
<mmWa>			

Note

If the pressure unit selected represents a water column (inWa, mmWa, mWa) (inches/millimeters/meters of water), the reference temperature for water density must be specified in a separate menu (choices are

4 °C, 20 °C 60 °F).

If <User> is selected, the user unit must be defined. The display is:

1. Entry field.

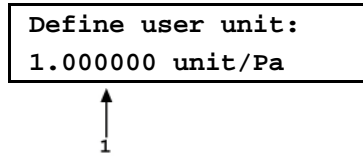

Enter the number of user units per Pascal (Pa) in the entry field. **ENTER** defines the user unit and returns to the <Set up unit #n> screen.

4.5.7 <Spec>, <Internal>

○ PURPOSE

To view, set, adjust, and maintain various aspects of PPC4's internal operation (see Section 3.2.27).

○ OPERATION

To access the internal selections use <Spec>, <Internal>. The display is:

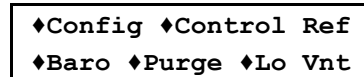

The INTERNAL menu choices include:

- <Config> To run an automated routine that readjusts internal pressure control coefficients (see Section 4.5.7.1).
- <Control Ref> To view or manually set the **EXHAUST** port condition (see Section 4.5.7.2).
- <Baro> View the real time output of the on-board barometer, if present (see Section 4.5.7.3).
- <Purge> Turn the automated purging function ON and OFF (see Section 4.5.7.4).
- <Lo Vnt> Operate Q-RPT module Gxxx and BGxxx TEST (-) Vent valve directly (see Section 4.5.7.5).

4.5.7.1 <Config>

○ PURPOSE

To run an automated routine that readjusts internal pressure control coefficients. This function is considered part of PPC4 maintenance and is therefore covered in the maintenance section of this manual (see Section 7.5).

○ OPERATION

This function is considered part of PPC4 maintenance and is therefore covered in the maintenance section of this manual (see Section 7.5.1).

4.5.7.2 <Control Ref>

○ PURPOSE

To specify whether PPC4 should automatically determine whether a vacuum source or atmospheric pressure is connected to its **EXHAUST** port or to manually set the **EXHAUST** port condition (see Section 3.2.27.1).

○ OPERATION

To access the CONTROL REFERENCE function use **<Spec>**, **<Internal>**, **<Control Ref>**. The display is:

Control Ref: ♦Auto ♦Vac ♦Atm ♦View

Select:

- <Auto>** To set the PPC4 to determine the **EXHAUST** port condition automatically using its internal exhaust sensor. This is the normal Control Ref setting.
- <Vac>** To set the PPC4 to assume that a vacuum supply is connected to the **EXHAUST** port.
- <Atm>** To set the PPC4 to assume that the **EXHAUST** port is open to atmospheric pressure.
- <View>** To view the current **EXHAUST** port condition assumed by PPC4 and how it was determined.

4.5.7.3 <Baro>

○ PURPOSE

To view the value of atmospheric pressure as measured by the PPC4 on-board barometer (see Section 3.2.27.3).

○ OPERATION

Note

PPC4s that have Gxxx Q-RPTs (no Axxx, BGxxx or utility sensor) are NOT equipped with an on-board barometer.

To view the current reading of the on-board barometer use **<Spec>**, **<Internal>**, **<Baro>**. The display is in the active pressure unit of measure (see Section 3.2.10).

4.5.7.4 <Purge>

○ PURPOSE

To enable and disable the PURGE function which automates the use of the optional Self Purging Liquid Trap (SPLT) (see Section 3.2.17).

○ OPERATION

To access the purge enable/disable function use **<Spec>**, **<Internal>**, **<Purge>**. **<Yes>** to enable purge or **<No>** to disable purge.

⚠ Caution

When the purge function is enabled, PPC4 makes background use of valve driver channel #8 independently of user actions (see Sections 3.2.17, Section 3.2.23).

4.5.7.5 <Lo Vnt>

○ PURPOSE

To cause a PPC4 or external RPM4's Gxxx or BGxxx Q-RPT TEST (-) vent valve to stay open or closed rather than open and close automatically (see Section 3.2.27.5).

Note

This feature is active only when the active Q-RPT is a Gxxx (gauge) or BGxxx (bi-directional gauge) Q-RPT.

○ OPERATION

Note

The normal setting for the TEST (-) vent valve is <Auto> in which PPC4 automatically controls the valve based on current PPC4 operation. Settings other than <Auto> should only be selected by advanced users.

To access the LO VNT function use <Spec>, <Internal>, <lo vent>. If a Gxxx (gauge) or BGxxx (bi-directional gauge) Q-RPT is not active, the display is: <Available with Gxxx or BGxxx Q-RPT only>.

If a Gxxx or BGxxx Q-RPT is active, the display is:

TEST (-) Vent: ♦Auto ♦Open ♦Close ♦View
--

<Auto> for the TEST (-) vent valve operation to be controlled automatically by PPC4 based on current operation. This is the default and recommended setting.

<Open> to cause the TEST (-) valve to open and remain open regardless of PPC4 operation until the setting is changed.

⚠ Caution

If the PPC4 detects a condition in which it determines there could be a risk of overpressure to the RPT by opening the TEST (-) Vent valve when a Manual Open is requested, a message indicating a DP overpressure risk is displayed. If this message is displayed, return to normal operation, vent the PPC4 and try again.

<Close> to cause the TEST (-) valve to close and remain closed regardless of PPC4 operation until the <Lo Vnt > setting is changed.

<View> to view the current condition of the TEST (-) valve. The display indicates whether current valve operation is controlled by the PPC4 (<Auto TEST (-) vent>) or has been set manually (<Manual TEST (-) vent>) followed by the current valve status (<Open> or <Close>).

4.5.8 <Spec>, <Cal>

○ PURPOSE

To calibrate the PPC4 utility sensor, Hi and/or Lo Q-RPTs and adjust the on-board barometer. This function is considered part of PPC4 maintenance and is therefore covered in the maintenance section of this manual (see Sections 7.2, 7.3, 7.4).

○ OPERATION

See Sections 7.2, 7.3 and 7.4.



4.5.9 <Spec>, <Log>



○ PURPOSE

To view and/or clear the PPC4 event log (see Section 3.2.27.5).

○ OPERATION

To view the event log press <Spec>, <Log>.

 and  to move back and forth between older and newer log entries.

Each log entry has two screens, one with the event description and one with the even time and date.  and  to toggle between the two screens. The oldest logged event appears.

After the last log has been viewed, the option to clear the log, <No>, <Yes> is presented. <Yes> to remove all entries from the log. <No> to continue without altering the log.

 to leave the log.

4.5.10 <ARange>

○ PURPOSE

To automatically set up PPC4 to optimize its measurement and control characteristics and features to cover a specific pressure range (see Section 3.2.8).

○ OPERATION

To use the AutoRange function, press <ARange> from the Main Menu and respond to the PPC4's prompts.

- ❶ **Select AutoRange measurement mode:** The screen is identical in appearance and function to the <Mode> screen (see Section 4.5.15). The choice of measurement modes offered reflects all the Q-RPT types available (Axxx, Gxxx, BGxxx) in the PPC4 system, not just the active Q-RPT.
- ❷ **Select pressure unit of measure:** The screen is identical in appearance and function to the <Unit> screen (see Section 4.5.13).
- ❸ **Enter the AutoRange full scale pressure:** Enter the full scale pressure value in the <-----> entry field and . If the full scale pressure entered cannot be covered by any of the Q-RPTs available, an error message is displayed. If the full scale pressure can be covered by an available Q-RPT, AutoRange proceeds to the range display.

Caution

RPM4 with Q-RPT full scale spans below 14 MPa have SDS self defense system to isolate and protect the Q-RPTs. If an external RPM4 SDS pressure rating is less than the PPC4 maximum pressure then AutoRanged ranges greater than the SDS rating are not allowed (see Sections 3.2.5, 6.5.4, 3.2.8). In order to create AutoRanged ranges or generate pressures above the SDS pressure rating the RPM4 must be disconnected or the RPM4 SDS must be upgraded to a higher pressure rating. Upgrades may be done at the DH Instruments service center (see Table 36).

④ **View proposed AutoRange range:** The proposed AutoRange range screen is:

1. Indication that this is a screen of the proposed AutoRange range.
2. Designator and position of the Q-RPT that AutoRange has selected to cover the AutoRange full scale and measurement mode.
3. Pressure unit of measure specified in AutoRange.
4. AutoRange full scale pressure in gauge mode and absolute mode if available. Shows absolute mode only if AutoRange measurement mode is absolute and full scale is less than 100 kPa (14.5 psi). Gauge mode only if the Q-RPT is a Gxxx, BGxxx or Axxx with absolute OFF.

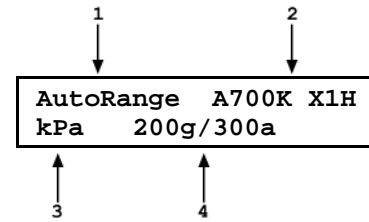

⑤ **Accept proposed AutoRange:** **ENTER** to accept the proposed AutoRange and go the Main Run Screen with the AutoRange range active. To modify the AutoRange full scale, measurement mode or pressure unit of measure, **ESC** to back up through the AutoRange screens and make changes.

If you would like to use a Q-RPT other than the one selected by AutoRange, use **<RPT>** in the Main Menu.. Only Q-RPTs that can cover the specified full scale and measurement mode are shown. **ENTER** when the desired Q-RPT is displayed.

⚠ Caution

Before operating PPC4 with external Q-RPTs, check carefully that the Q-RPT TEST(+) port is connected to the PPC4 TEST(+) port. If the external Q-RPT is NOT connected to the PPC4 TEST(+) port, it will not measure the pressure generated by PPC4 and PPC4 may reach a pressure higher than the target pressure before its watchdog function recognizes that the external RPT is not connected.

4.5.11 <Leak>

○ PURPOSE

To run an automated leak check routine that determines the leak rate of the system connected to the PPC4 **TEST(+)** port (see Section 3.2.18).

○ OPERATION

To run a leak check, first set the pressure to the desired leak check pressure using the direct pressure control keys (see Section 3.2.1) or automated pressure control (see Section 4.2.1).

To access the LEAK CHECK function, use **<Leak>** from the Main Menu screen. Select **<Run>** to run a leak test. The display is:

1. Edit field for the time over which the leak check pressure change will be measured, in seconds.

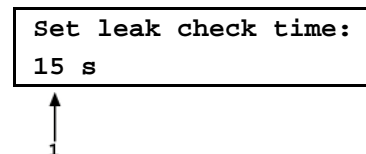

Edit the leak check time if desired (minimum 1, maximum 999) then **ENTER**. **ENTER** again when ready to start the leak test. The leak test display is:

1. Standard Main Run Screen first line showing measured pressure.
2. Active RPT position indicator
3. Indication that leak test is running and countdown of time remaining.

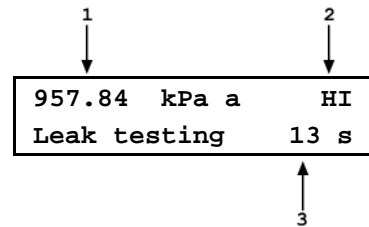

ESC can be used to abort the running leak test. **ENTER** while the leak test is running restarts the leak check timer. When the leak check timer countdown has completed, the leak check results screen is displayed:

1. Total pressure change from start to finish of leak check time.
2. Indicator of RPT used to run leak check.
3. Average rate of change of pressure over the leak check time period.

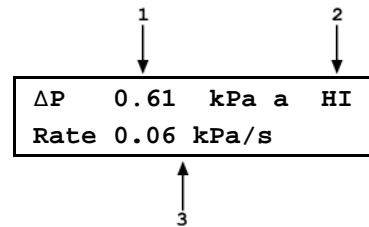

From the leak check results screen, **ENTER** to repeat the leak test.

ESC to return to leak check Main Menu and exit to the Main Run Screen.

To view the results of the most recently completed leak check, press **<View>**. If NO leak check data is stored (i.e., if the PPC4 has never run a leak test or a reset has cleared previous leak test results), the results screen displays **<Data not available>** briefly and returns to Main Run Screen. **ENTER** or **ESC** to return to the Main Run Screen.

4.5.12 <RPT>

○ PURPOSE

Search for, initialize and display internal and external Q-RPTs available to the PPC4 system (see Section 3.2.5).

⚠ Caution

- Before operating PPC4 with external Q-RPTs, check carefully that the Q-RPT TEST(+) port is connected to the PPC4 TEST(+) port. If the external Q-RPT is NOT connected to the PPC4 TEST(+) port, it will not measure the pressure generated by PPC4 and PPC4 may reach a pressure higher than the target pressure before its watchdog function recognizes that the external RPT is not connected.
- RPM4 with Q-RPT full scale spans below 14 MPa have SDS self defense system to isolate and protect the Q-RPTs. If an external RPM4 SDS pressure rating is less than the PPC4 maximum pressure then a warning will be displayed on the PPC4 front panel when the RPM4 is detected. In addition, AutoRanged ranges greater than the SDS rating are not allowed (see Sections 3.2.5, 6.5.4, 3.2.8). In order to create AutoRanged ranges or generate pressures above the SDS pressure rating the RPM4 must be disconnected or the RPM4 SDS must be upgraded to a higher pressure rating. Upgrades may be done at the DH Instruments service center (see Table 36).

○ OPERATION

To run the Q-RPT and utility sensor search and initialize function, select **<RPT>** from the Main Menu. PPC4 displays **<Searching for RPTs...>** while it runs the search function. When the RPT search is complete, the Q-RPTs identification screen is displayed.

1. IH, and L: Identification of RPTs in Internal (PPC4), Hi and Lo positions.
2. X1H and L: Identification of RPTs in External (RPM4), Hi and Lo positions.

IH:A7Mu	L:none
X1H:A7M	L:A700K

The cursor is on the position designator of the active Q-RPT or utility sensor. Use the cursor control keys to move the cursor to other positions and to view the third line if present. **ENTER** to make the selected Q-RPT or utility sensor active in its default range (see Section 3.2.6). **<RPT>** again to cause the Q-RPT search to run again. **ESC** to return to the Main Run Screen without making any changes.

4.5.13 <Unit>

○ PURPOSE

To select the unit of pressure in which PPC4 displays pressure values (see Section 3.2.10).

○ OPERATION

To change the pressure unit of measure for the active range, use **<Unit>** from the Main Menu screen while the range is active. The display is:

◆kPa	◆Pa	◆MPa
◆hPa	◆bar	◆mbar

The cursor is on the number corresponding to the pressure unit of measure active for the current range.

To change the pressure unit of measure, select the desired unit. Making the selection returns to the Main Run Screen with the selected unit active.

4.5.14 <Range>

○ PURPOSE

To view and/or change the active pressure measurement range and associated settings (see Section 3.2.9).

○ OPERATION

<Range> from the Main Menu activates the range viewing and selecting function. When **<Range>** is first selected, the range identification screen for the active range is displayed. For example:

1. Q-RPT or utility sensor designator.
2. Type of range. DF for the Q-RPT's default range; AR for a range created by AutoRange.
3. Q-RPT or utility sensor position designator.
4. Current pressure unit of measure.
5. Full scale pressure in current unit of measure in gauge and/or absolute measurement mode depending on type of Q-RPT and range.

	1	2	3
	↓	↓	↓
	Active	A700K	DF IH
	psi	100g/100a	
↑	↑	↑	
3	4	5	

To select a range to become the active range, **ENTER** while the desired range is displayed. PPC4 must be vented for the range change to occur. **VENT** if necessary to complete the range change.

When selecting a range, if the range's Q-RPT is an external Q-RPT and the PPC4 cannot communicate with it, PPC4 displays **<Cannot find range's external Q-RPT (Xn)>**. **ENTER** or **ESC** to return to the range selection screen. For information on setting up and communicating with external Q-RPTs see Section Section 2.3.6.

ESC while in the RANGE function returns to the Main Run Screen with no range change having been made.

4.5.15 <Mode>

○ PURPOSE

To set the measurement mode (absolute, gauge or negative gauge) for the active range (see Section 3.2.11).

○ OPERATION

To change the active measurement mode for a range, use **<Mode>** from the Main Menu screen while the range is active. The display depends upon the Q-RPT or utility sensor that is active.

```
Measurement Mode:
◆Abs ◆Gage ◆Neg Gage
```

If an Axxx Q-RPT or a utility sensor is active, all three measurement modes are supported: absolute, gauge and negative gauge. Only gauge is available if absolute and negative gauge modes are OFF (see Section 7.2.5).

If a Gxxx Q-RPT is active, only gauge measurement mode is supported. When **<Mode>** is selected, **<Gauge RPT, gauge mode only>** is displayed.

4.5.16 <Head>

○ PURPOSE

To edit the pressure fluid head correction added or subtracted to the pressure measured by the PPC4 reference pressure transducer in order to predict the pressure at a height other than the PPC4 reference level (see Section 3.2.16).

○ OPERATION

To access the HEAD function, use **<Head>**. The display is:

1. Entry field for head height.
2. Test gas currently specified for the head correction.

```
Edit Head Height:
+ 25 cm N2
```

↑ ↑
1 2

Edit the head height to the desired value. **ENTER** to return to the Main Run Screen with the new head correction active. **ESC** to return with no changes.

Note

The reference height of the PPC4 pressure measurement is the middle of the PPC4 TEST port. The head height should be entered as a positive value if the device or system under test is higher than the PPC4 and negative if it is lower.



4.5.17 <Purge>

○ PURPOSE

To execute the PPC4 test system PURGE function using the optional Self Purging Liquid Trap (SPLT). PURGE is used to collect and exhaust liquid contaminants from the device or system under test before they reach the PPC4 (see Section 3.2.17).

○ OPERATION

Note

For the Purge function to execute, the function must have been enabled using <Spec>, <Internal>, <Purge> (see Section 4.5.7.4) and an optional Self Purging Liquid Trap (SPLT) must be installed in the test line (see Section 2.3.7.1).

To purge the UUT and/or system under test using the PURGE function, proceed as follows:

- ❶ **Connect the system or device under test (UUT) to the PPC4 TEST(+) port:** Make sure the optional SPLT is properly installed between the UUT and the PPC4, TEST(+) port including the electrical connection for the PPC4 DRIVER connector to the SPLT valve. Always clean as much liquid and contamination as possible out of the UUT before connecting it.
- ❷ **Set the purge pressure:** Use the PPC4 direct pressure control keys (see Section 3.2.1) or automated pressure control (see Section 4.2.1) to set the purge pressure. The purge pressure should be roughly the UUT full scale or 1 MPa (150 psi), whichever is lower. Avoid activating the purge function at pressure > 1 MPa (150 psi).
- ❸ **Select <Purge> from the Main Menu:**

Note

ESC at any time during execution of the purge routine causes the purge function to abort and returns to the Main Run Screen.

Confirm your intention to run the PURGE routine with **ENTER**.

If the current pressure is over 700 kPa (100 psi) gauge, the display is:

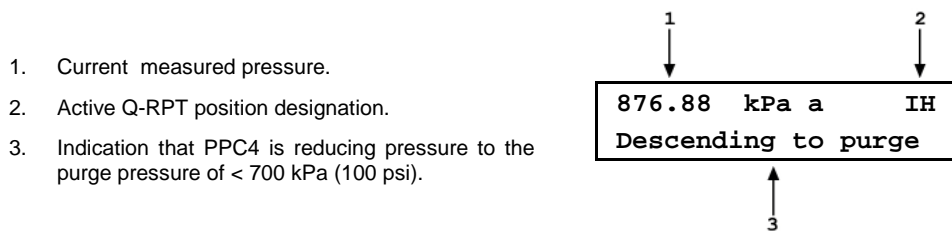

1. Current measured pressure.
2. Active Q-RPT position designation.
3. Indication that PPC4 is reducing pressure to the purge pressure of < 700 kPa (100 psi).

PPC4 controls pressure down to less than 700 kPa (100 psi), stops control and displays **<Preparing to purge>** for five seconds. After the five second delay, PPC4 opens the SPLT exhaust valve and displays **<PURGING>**.

Once the pressure reaches less than 20 kPa (3 psi) gauge or 110 kPa (16 psi) absolute, PPC4 opens its internal vent valve and returns to the Main Run Screen in its normal vented condition.

- ❹ Repeat steps ❷ and ❸ until no liquids or other contaminants are expelled when the SPLT exhaust valve opens.

5. Advanced User Interface

5.1 Main Run Screen

The PPC4-ui Main Run Screen is the home display for the advanced user interface. It is displayed on power-up and is the screen from which all other functions and menus are accessed. It is the top level of the menu structure.

The Main Run Screen is where the operator works with PPC4 to set and read pressures. It provides complete information on the system's current configuration and operating status.

Figure 11 shows the PPC4 Main Run Screen display fields and selectable fields. Table 15 lists the contents and purpose of these fields as well as references to manual sections for more detailed information and explanation.

Note

PPC4 has a screen saver function that is enabled after a period of inactivity. Pressing any key or rotating the knob restores the display. The screen saver display can be selected, the time delay can be changed or screen saving can be suppressed (see Section 5.7.7.1).

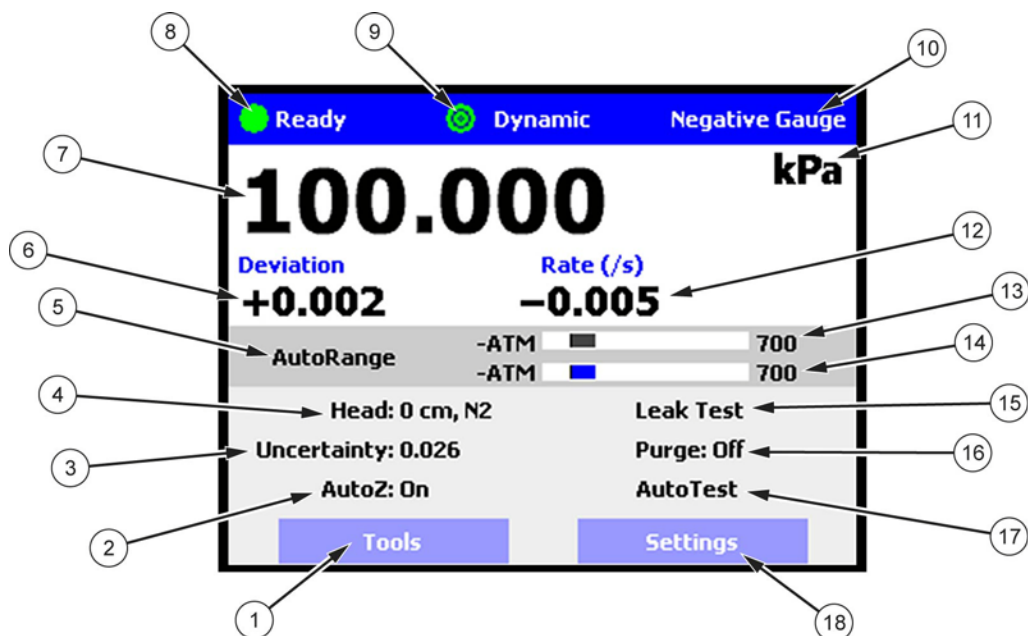

Figure 11. Main Run Screen Display and Selectable Fields (see Table 15)

Table 15. Main Run Screen Fields and Buttons

FIELD	DESCRIPTION	PURPOSE	CONTENTS	SECTION
①	[Tools] button	Access PPC4 Tools functions		none
②	AutoZero	Shortcut to run AutoZero screen (absolute measurement mode only)		5.7.5.1
③	Uncertainty	Shortcut to the Uncertainty settings screen	Measured pressure uncertainty value	7.2.7.3
④	Head	Shortcut to the Head settings screen	Current pressure head value, fluid	5.7.6.3
⑤	[AutoRange] button	<i>Enter</i> the AutoRange screen		5.7.1
⑥	Target Pressure Pressure Information	<i>Enter</i> to set target pressure. Display pressure information depending on PPC4 function. Label above defines contents.	Numeric value and sign Label: Target (control target pressure) or Deviation (deviation from target value)	5.5.1
⑦	Measured Pressure	Display pressure measured by active Q-RPT Shortcut to Resolution Screen	Numerical pressure value and sign	5.7.6.4
⑧	<i>Ready/Not Ready</i> indicator	Indicate pressure <i>Ready/Not Ready</i>	<Green> : <i>Ready</i> <Yellow> : <i>Near Ready</i> <Red> : <i>Not Ready</i>	3.2.3
⑨	Control Mode Control Status Indicator	Indicate current control mode and control status Shortcut to control settings screen	Control mode: Static or Dynamic Indicator solid : not controlling Indicator animated : controlling	5.7.8.2
⑩	Measurement Mode	Identifies measurement mode of displayed pressure Shortcut to measurement mode screen	Absolute Gauge Negative Gauge	5.7.6.2
⑪	Unit of Measure	Identifies pressure unit of measure in which measured pressure and pressure information values are displayed Shortcut to unit of measure screen	Pressure unit of measure abbreviation	5.7.6.1
⑫	Pressure Rate of Change	Display rate of change of pressure in current units per second	Numerical value and sign in current pressure units/s	none
⑬	AutoRange Range Indicator	Display AutoRange limits	Lower and upper limits of AutoRanged range with bar graph of measured pressure	3.2.6 5.7.1
⑭	Active Q-RPT Span Indicator	Display active Q-RPT limits	Lower and upper limits of Q-RPT span with bar graph of measured pressure	3.2.6
⑮	Leak Test	Shortcut to leak test screen		5.7.3.2
⑯	Purge	Shortcut to purge screen		5.7.3.1
⑰	AutoTest	Shortcut to Advanced AutoTest		5.7.2
⑱	[Settings] button	<i>Enter</i> the PPC4 Settings menu		none

* Noted fields have pressure values expressed in current pressure units.

5.2 Other Screens

All lower level screens (screens other than the Main Run Screen) have similar formats. The screen in Figure 12 shows one possible lower level screen shown by selecting **[Settings], <Pressure>**. Numbered displays and selectable fields are described in Table 16.

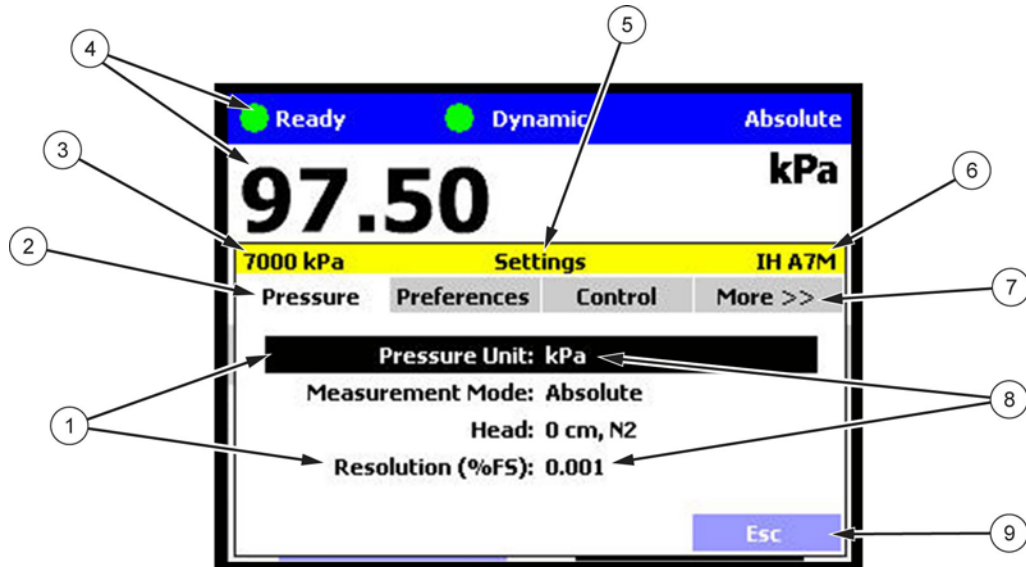

Figure 12. Advanced Interface Lower Level Screen Example (see Table 16)

Table 16. Lower Level Screen Displays and Selectable Fields

FIELD	DESCRIPTION	CONTENTS
①	Selectable fields	Display list of fields available for selection and editing in currently active tab <Pressure>
②	Tabs <Pressure> , <Preferences> , <Control> and <More >>>	Available tabs for selection. Each tab contains selectable or editable fields.
③	Current AutoRange Range	Value of range in currently active unit of measure
④	Current Pressure, <i>Ready</i> Status and Control Indicator	Ready Indicator, Control Indicator, Measurement Mode, Pressure and Unit of Measure
⑤	Screen Heading	Heading of currently active screen
⑥	Active RPT and Location	IH Internal Hi IL Internal Lo X1H External RPM4 Hi X1L External RPM4 Lo
⑦	<More >>> tab	Show more tabs available for selection
⑧	Current values	Some editable fields display current values on the selection screen for convenience so the user can see them without having to select the field and change screens to do so.
⑨	[Esc] button	Returns to Main Run Screen

5.3 Keypad Layout and Protocol

The PPC4 has a keypad and navigation knob for local operator access to on screen menus and for data entry in addition to direct pressure control keys.

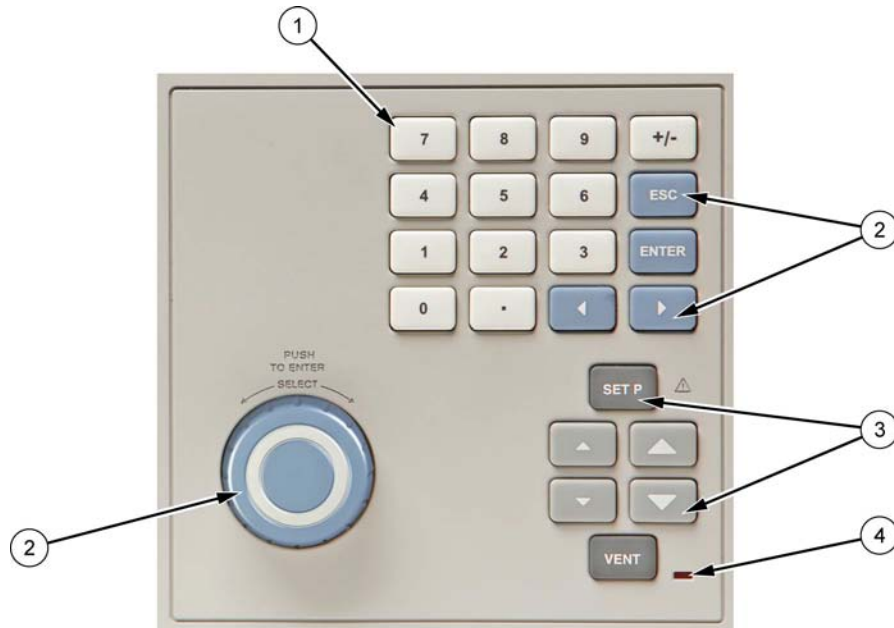

- ① Numeric keypad (black characters on white keys)
- ② Navigation controls – navigation keys and knob for selecting and entering menus and fields in the graphic display (white characters on blue keys)
- ③ Direct pressure control keys to manually control pressure, enter a target pressure or toggle the vent sequence. (white characters on grey and black keys)
- ④ Vent indicator LED

Figure 13. Keypad layout

5.4 Conventions for the Advanced Interface

5.4.1 Navigation Controls and Keypad

Menu navigation and selection with the graphical display is described in the text as follows:

- **[xxx]** indicates buttons, (i.e. **[Tools]**)
- **<xxx>** indicates tabs (i.e. **<Control>**)
- **xxx** indicates other fields (i.e. **Unit**)

Buttons, tabs and fields used in sequence are shown on one line, separated by commas, for example:

[Settings], <Pressure>, Unit

Front panel keys are shown as individual keys, (i.e. **ENTER**)

Note

For dedicated front panel keys, such as **ESC**, **VENT**, **SET P**, and **ENTER**, any time a key is shown in the manual, it should be interpreted to mean “press this key”. For example: **ESC** to return to the Main Run Screen means “Press the **ESC** button to return to the Main Run Screen”.

The numeric keypad is used for data entry and editing. Pressing **+/-** changes the numerical sign when editing.

5.4.2 Navigating Advanced Interface Menus

Note

Throughout the Advanced Interface section of the manual the following terms are used, when presented with initial capitals and in italics, these words have the following meanings:

Select Move the cursor or screen focus between fields by rotating the knob. Can also use the cursor control keys (◀ and ▶) to move the cursor.

Enter Push the knob on a Selected field. Can also use **ENTER**.

The advanced interface is a “point and click” style interface, much like navigating on a computer screen. Simply *Select* a button, tab or field on the screen and then *Enter* to move forward in the menu selection. To edit a field either *Select* the field and *Enter* or start editing the value with the keypad. *Enter* to accept an entry.

ESC typically returns to the Main Run Screen from other screens or causes execution to cease or suspend if an automated process or sequence is in operation. **ESC** from the Main Run Screen allows momentary viewing of the PPC4 model information screen.

Examples of typical screens and descriptions of how to navigate in them are shown in the following examples.

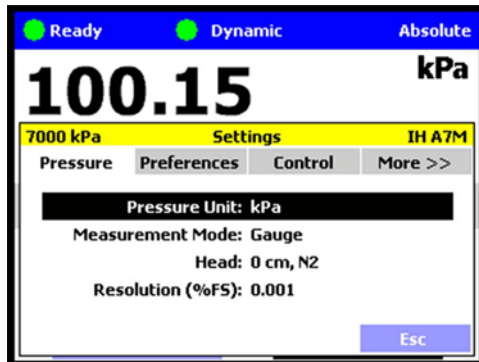

Example 1: Selecting an Individual Field from a Tabbed Form.

[Settings], <Pressure>, Pressure Unit

Enter [Settings] to open the Settings tab screen. From here scroll between tabs <Pressure>, <Preferences>, <Control> and <More >>.

Entering the <Pressure> tab from the Settings screen enters the Pressure settings screen, shown. From here select and Enter a field in the <Pressure> tab.

[Esc] or **ESC** to return to the Main Run Screen.

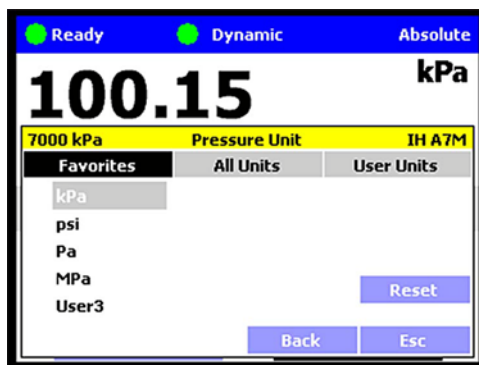

Example 2: Continuing from Example 1 to select a unit of “psi” from a List.

[Settings], <Pressure>, Pressure Unit, <Favorites> psi

Enter the Pressure Unit field from the <Pressure> tab to display the Pressure Unit screen. Scroll between tabs <Favorites>, <All units> or <User units>.

Enter <Favorites> to allow selecting one of the five most recently used units and entering a new unit, for example “psi”. The currently active selection is shown in gray.

[Back] to go back one menu level to the Settings screen.

[Esc] or **ESC** to return to the Main Run Screen without making a new selection.

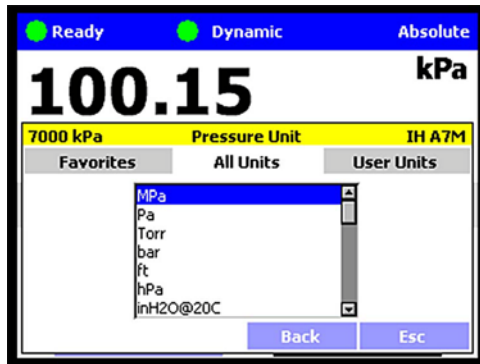

Example 3: Selecting from a Scrolling List.

[Settings], <Pressure>, Pressure Unit, <All units>, MPa

Continuing from Example 1, Enter **Pressure Unit** and then **<All Units>** presents a list of units with a scroll bar at the right. Rotating the knob clockwise or pressing **▶** scrolls down in the list. Rotating the knob counterclockwise or pressing **◀** scrolls up. Click the knob or **ENTER** to select.

From inside a scrolling list press **ESC** to exit back to the tab screen. From the tab screen, either select another tab, enter the scrolling list again or use **[Back]** or **[Esc]**.

[Back] to go back one menu level to the Settings screen.

[Esc] or **ESC** to exit the menu and make no change.

Example 4: Editing a Numeric Value.

[Settings], <Pressure>, Pressure Unit, <User units>, User Defined #1

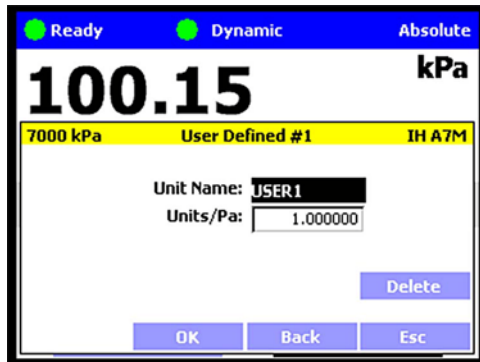

To create or edit a User defined unit, Enter **<User units>** in the Unit screen. Enter **Units/Pa** and input a value using the numeric key pad.

[OK] to accept.

[Back] to go back one menu level to the Settings screen.

[Esc] or **ESC** to return to the Main Run Screen and make no change.

Note

- Whenever the **[OK]** button is present it is necessary to press **[OK]** to accept any changes or they will be discarded.
- When highlighted, numeric fields have white text on black backgrounds. When editing, numeric fields change to black text on white background.

Example 5: Selecting from a Drop Down List.

[Settings], <Remote>, COM1

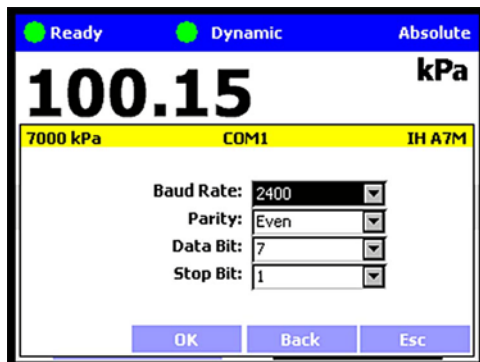

A field, such as **Baud Rate**, **Parity**, **Data Bit** or **Stop Bit** in the COM1 screen is in drop down menu format. Enter one of these fields to display a list of the selections available.

Note

When the **[OK]** button is present it is necessary to press **[OK]** to accept any changes or they will be discarded.

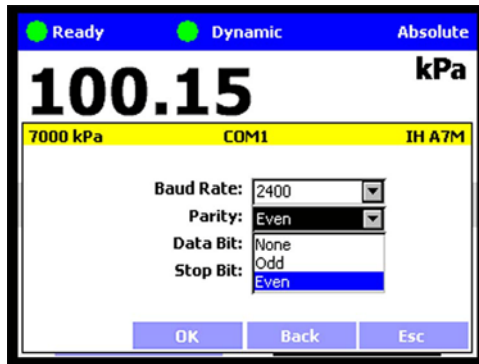

Continuing Example 5, entering **Parity** displays a list. *Select* and *Enter* to accept the new parity value.

[Settings], <Remote>, COM1, Parity

[OK] to accept the changes.

[Esc] or **ESC** to make no change.

Note

When the [OK] button is present it is necessary to press [OK] to accept any changes or they will be discarded.

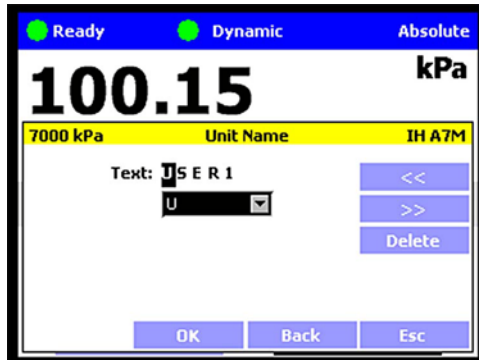

Example 6, editing a text field.

[Settings], <Pressure>, Pressure Unit, <User Units>, User Defined #1, Unit Name

[<<] and [>>] position the cursor over a character. *Enter* or **ENTER** to open the drop down selection of letters, numbers and symbols. Scroll through the list to select. *Enter* or **ENTER** the desired character and advance to the next letter.

[Delete] to remove the character.

When the [OK] button is present it is necessary to press [OK] to accept any changes or they will be discarded.

5.5 Pressure Control

5.5.1 Set Pressure Automatically

○ PURPOSE

To use the automated pressure control functions of PPC4 to set and maintain target pressure values (see Section 3.2.12).

○ OPERATION

To set a pressure, **SET P** from the Main Run Screen or click on the **Target Pressure** field of the Main Run Screen. The Set Pressure screen will display with the Target Pressure field highlighted. Using the numeric keypad, enter the target pressure value as desired (see Section 5.5.1.2 for information on zero pressure commands).

Press **ENTER** or click the knob to accept the target value and start the pressure control sequence, returning to the Main Run Screen. The Main Run Screen during active pressure control depends on whether or not the pressure control is *Ready* or *Not Ready* (see Section 3.2.3).

When the pressure is approaching the target (*Not Ready*) the window displays the Measured Pressure and, below, the Target Pressure (labeled Target). The Ready indicator is either Red while pressure is slewing to the target (*Not Ready*) or Yellow (*Near Ready*) when the fine pressure control is approaching the target.

In dynamic control mode (see Section 3.2.2.1), when the pressure has reached the target pressure within the defined Ready criteria, the Target pressure is shown in place of the measured pressure and, below, the difference in actual pressure from target is shown (labeled Deviation). In static control mode (see Section 3.2.2.2), the measured pressure is shown continuously along with Target and Rate.

Observe the *Ready/Not Ready* indicator (see Section 3.2.3) for indication of when the controlled pressure has reached the target and stabilized. PPC4 continues controlling

following static or dynamic control operation protocol (see Section 3.2.2) until automated pressure control is interrupted.

5.5.1.1 Interrupting Automated Pressure Control

Automated pressure control is interrupted by:

- **ESC**: Suspends control and remains in Main Run Screen. Does not vent pressure. PPC4 passively measures the pressure applied to its **TEST(+)** port.
- **Selecting any field or shortcut key with the knob or the cursor control keys** **◀**, **▶** and **ENTER**: Suspends control and goes to the selected function. Does not vent pressure. PPC4 passively measures the pressure.
- **Selecting and entering the target pressure screen with the knob or pressing** **SET P**: Suspends control and goes to Set Pressure screen. Does not vent pressure. PPC4 passively measures the pressure applied to its **TEST(+)** port.

To resume automated pressure control, press select and enter the target pressure screen or press **SET P** then **ENTER** a target pressure value.

5.5.1.2 Automated Pressure Commands for Zero Pressure

Zero in gauge mode:

A command for automated pressure control to a target value of zero when in **gauge or negative gauge** measurement mode is interpreted in the same manner as if **VENT** had been pressed (see Section 3.2.14). A *Ready* condition occurs when the vent sequence has completed, including running AutoZ if applicable (see Section 3.2.22).

Zero in absolute mode:

In response to a command for automatic pressure control to a target value of zero when in **absolute** measurement mode, PPC4 opens its down control valves fully to the **EXHAUST** port allowing the vacuum source connected to the **EXHAUST** port to pull down the pressure as far as possible (see Figure 31). The down valves stay open until another pressure command is given or control is aborted. How low the pressure in the PPC4 and the system connected to the PPC4 **TEST(+)** will go is a function of the quality of the vacuum pump used, the characteristics of the volume and tubing connected to the **TEST(+)** port and PPC4's internal restrictions.

A *Ready* condition occurs when the pressure control stability limit is reached (see Section 3.2.3). Measured pressure will continue to display even when *Ready*.

5.5.2 Manual Pressure Control

○ PURPOSE

The manual pressure control keys provide direct manual control to increase, decrease, and jog the PPC4 pressure.

○ OPERATION

▲ or **▼** when automatic control is not active causes pressure to increase or decrease at the fast slew rate.

▲ or **▼** when automatic control is active produces no response.

▲ or **▼** when automatic control is not active causes pressure to increase or decrease at the slow slew rate.

▲ or **▼** during dynamic control causes the pressure to jog or step by a fixed amount. During active dynamic pressure control, they cause the target pressure to be changed by the fixed amount. One press causes one step. The approximate value of the step is set

automatically depending on the current active PPC4 range. The value can be adjusted by navigating to **[Settings]**, **<Control>**, **Jog Step** (see Section 5.7.8.3).

5.5.3 Vent

○ PURPOSE

VENT activates a sequence to bring the test pressure to atmosphere (see Section 3.2.14).

○ OPERATION

VENT causes PPC4 to control pressure to near atmospheric pressure and then open the system vent valve (see Figure 31 and Figure 32). On-going execution of the vent function is indicated by lighting a RED LED to the left of the **VENT** key. Completion of the vent process is indicated by the *Ready/Not Ready* indicator light becoming GREEN with the vent RED LED still lighted. The vent valve remains open until **VENT** is pressed again, another direct pressure control key is pressed, or an automated pressure control command is given.

5.6 Advanced Interface Menus

5.6.1 Shortcuts

All PPC4 Advanced Interface functions are available through the Main Run Screen buttons (**[Tools]**, **[Settings]** and **[AutoRange]**) and the direct pressure control keys such as **SET P** and **VENT**. Shortcuts give quick access to the most common functions. The shortcut fields are identified in Figure 11 and Table 17. *Enter* a shortcut to navigate directly to the menu associated with that function.

For example, clicking on the **Unit of Measure** (see item 11 in Figure 11 and Table 15) is the same as navigating the menu sequence: **[Settings]**, **<Pressure>**, **Pressure Unit**. Table 17 lists each shortcut and the associated menu for each.

5.6.2 Menu Structure

Table xx shows the top level menu structure for the Advanced Interface. Most day to day operations are accessible through the shortcuts (see Section 5.6.1). All functions are available through menus that are grouped by functionality.

Note

[Settings] contains numeric entries that determine how the PPC4 will operate, what calculations will be made and environment and setup commands. Typically Settings functions are entered only to set up the PPC4 prior to performing some action or starting a series of tests.

[Tools] is for action-oriented functions. **[Tools]** functions include AutoTest, Leak Test and other sequences that involve pressure control and measurement. Items in the Tools menu involve some kind of action.

[AutoRange] creates, edits and deletes AutoRanges, optimizing measurement and control of the PPC4 over specified ranges. (See Section 3.2.8)

Table 17. Advanced Interface Menu Structure

MENU SELECTION	SHORTCUT (SEE FIGURE)	SEE SECTION
Target Pressure or 		5.5.1
[AutoRange]		5.7.1
[Tools], <AutoTest>, Exercise		5.7.2.1
[Tools], <AutoTest>, Quick Test		5.7.2.2
[Tools], <Auto Test>, Advanced Test	AutoTest	5.7.2.3
[Tools], <Pressure>, Purge	Purge	5.7.3.1
[Tools], <Pressure>, Leak Test	Leak Test	5.7.3.2
[Tools], <Drivers>		5.7.4
[Tools], <System>, Run AutoZ	AutoZero	5.7.5.1
[Tools], <System>, Control Configuration		5.7.5.2
[Tools], <System>, Resets		5.7.5.3
[Settings], <Pressure>, Pressure Unit	Unit of Measure	5.7.6.1
[Settings], <Pressure>, Measurement Mode	Measurement Mode	5.7.6.2
[Settings], <Pressure>, Head	Head	5.7.6.3
[Settings], <Pressure>, Resolution	Measured Pressure	5.7.6.4
[Settings], <Preferences>,Screen saver		5.7.7.1
[Settings], <Preferences>, Sounds		5.7.7.2
[Settings], <Preferences>, Time		5.7.7.3
[Settings], <Preferences>, Language		5.7.7.4
[Settings], <Preferences>, Security		5.7.7.5
[Settings], <Control>	Control Mode	5.7.8
[Settings], <Remote>		5.7.9
[Settings], <Calibration> , Hi RPT, <Calibration>		7.2, 7.4
[Settings], <Calibration>, Hi RPT, <AutoZ>		7.2, 7.4
[Settings], <Calibration>, Hi RPT, <Uncertainty1>	Uncertainty (Hi RPT active)	7.2.7.3
[Settings], <Calibration>, Hi RPT, <Uncertainty2>		7.2.7.3
[Settings], <Calibration>, Lo RPT, <Calibration>		7.2, 7.4
[Settings], <Calibration>, Lo RPT, <AutoZ>		7.2, 7.4
[Settings], <Calibration>, Lo RPT, <Uncertainty1>	Uncertainty (Lo RPT active)	7.2.7.3
[Settings], <Calibration>, Lo RPT, <Uncertainty2>		7.2.7.3
[Settings], <Calibration>, Barometer		7.3
[Settings], <Internal>		5.7.12

5.7 Menu operation

5.7.1 AutoRange

○ PURPOSE

To automatically set up PPC4 to optimize its measurement and control characteristics and features to cover a specific pressure range (see Section 3.2.8).

○ OPERATION

To use the AutoRange function, use **[AutoRange]** from the Main Run Screen. The AutoRange screen shows the current settings on the left hand side and a series of buttons on the right for AutoRange actions. **[OK]** to accept and activate the AutoRange, **[Back]** or **[Esc]** to return to the Main Run Screen.

To choose an existing saved AutoRange, select from the contents of the **Range**: drop down menu and enter an existing range.

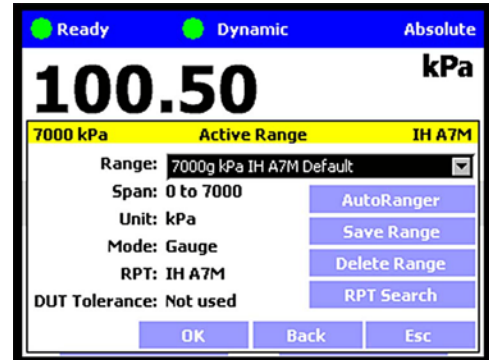

Note

The Default ranges of each of the available Q-RPTs are included in this list, representing the full scale ranges of the Q-RPTs. Default ranges cannot be deleted (see Section 3.2.6).

[AutoRanger]: creates a new AutoRange. The AutoRanger screen has the following fields to select:

Unit: The unit of measure associated with the AutoRange (see Section 3.2.10).

Note

Altitude units of measure (m, ft) are not supported for AutoRange.

Mode: The measurement mode associated with the AutoRange (see Section Section 3.2.11). The choice of measurement modes offered reflects all the Q-RPT types available (Axxx, Gxxx, BGxxx) in the PPC4 system, not just the active Q-RPT.

Full Scale: Edit the full scale pressure value in the unit of measure specified in the Unit field. **[OK]** to accept. If the full scale pressure entered cannot be covered by any of the Q-RPTs available, an error window is displayed (“No suitable RPTs found”). If the full scale pressure can be covered by an available Q-RPT, the entry is accepted.

Use UUT Tolerance: If this field is “Yes” the UUT Tolerance is used to determine the PPC4 resolution and hold limit settings for the resulting AutoRange. If this field is “No” the resolution and hold limit settings for the resulting AutoRange are determined based on the AutoRange full scale and the active selected Q-RPT.

UUT Tolerance: If enabled, the tolerance of the device under test, in % of AutoRanged span, associated with the resulting AutoRange.

[OK] from the AutoRanger screen continues to the AutoRange Confirmation screen, where the specified Full Scale, Unit, Mode and UUT Tolerance are listed in addition to the selected RPT. Selecting the **RPT** drop down list shows all available RPTs that can cover the specified AutoRange. If an RPT other than the one selected is desired, it may be chosen from this list.

Note

If an external Q-RPT that should be available is not being selected by AutoRange then choose **[AutoRange], **[RPT Search]** from the Main Run Screen and determine whether external Q-RPTs have been properly connected and initialized (see Section 2.3.6).**

[OK] from the AutoRange Confirmation screen creates the range, [Back] returns to the AutoRanger screen and [Esc] or **ESC** exits to the Main Run Screen and does not create the AutoRange.

[Save Range]: Click to save an AutoRange to the **Range** drop down list.

[Delete Range]: Click to delete the currently selected AutoRange from the **Range** drop down list.

[RPT Search]: To search for, initialize and display internal and external Q-RPTs available to the PPC4 system. Selecting an available Q-RPT changes Range to the default range of that Q-RPT.

Note

- **[Esc]** from the RPT Search screen the PPC4 will return to the Main Run Screen and no AutoRange changes that were made after the last **[Save]** will be stored.
- **[OK]** creates the newly defined AutoRange and to uses it in operation. If a range is selected from the list, **[OK]** changes the active range to the selected Range. **[Esc]** returns to the Main Run Screen without changing the currently active AutoRange.
- To verify or confirm the range from the Main Run Screen, use **[AutoRange]** from the Main Run Screen and view the **Range** field to view the active range (see Section 3.2.8) or view the AutoRange and active Q-RPT spans and indicators from the AutoRanger bar on the main run screen (see Figure 14).

The AutoRange Bar in the middle of the PPC4 Main Run Screen displays the range and a graphical indicator of the measured pressure within the range for both the active AutoRanged Range and the active Q-RPT (see Figure 14, showing a 200 kPa AutoRanged Span on a 700 kPa Q-RPT).

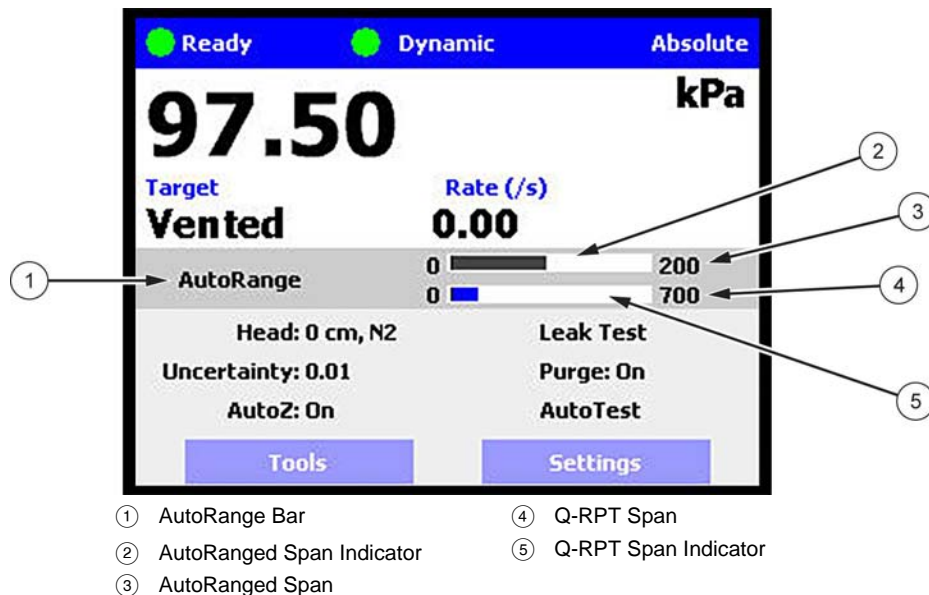

Figure 14. AutoRange Bar

⚠ Caution

- Before operating PPC4 with external Q-RPTs, check carefully that the Q-RPT TEST(+) port is connected to the PPC4 TEST(+) port. If the external Q-RPT is NOT connected to the PPC4 TEST(+) port, it will not measure the pressure generated by PPC4 and PPC4 may reach a pressure higher than the target pressure before its watchdog function recognizes that the external RPT is not connected.

- RPM4 with Q-RPT full scale spans below 14 MPa have SDS self defense system to isolate and protect the Q-RPTs. If an external RPM4 SDS pressure rating is less than the PPC4 maximum pressure then a warning will be displayed on the PPC4 front panel when the RPM4 is detected. In addition, AutoRanged ranges greater than the SDS rating are not allowed (see Sections 3.2.5, 6.5.4, 3.2.8). In order to create AutoRanged ranges or generate pressures above the SDS pressure rating the RPM4 must be disconnected or the RPM4 SDS must be upgraded to a higher pressure rating. Upgrades may be done at the DH Instruments service center (see Table 36).

5.7.2 AutoTest

○ PURPOSE

To execute a programmed sequence of automated pressure control target values and/or to AutoRange the PPC4 based on the full scale and tolerance of the device under test (see Section 3.2.15). **[Tools], <AutoTest>** accesses the main AutoTest menu.

5.7.2.1 Exercise

Exercise cycles pressure with the PPC4 between a minimum value (atmosphere or 0) and a maximum target. The PPC4 can start the descending portion of the cycle immediately or can control at the maximum target for a specified period of time before decreasing pressure.

○ OPERATION

To run an Exercise sequence, **[Tools], <AutoTest>, Exercise** from the Main Run Screen.

In the Exercise screen enter the following:

Cycles: The number complete (up and down) cycles for the exercise sequence (0 – 50).

Max Target: The maximum pressure of the target sequence. The PPC4 will control up to this pressure and either release or control at target, based on user selection. Value must be within the Upper and Lower limits of the current AutoRange span (see Section 3.2.8).

Min Target: The minimum pressure of the target sequence, selected from a drop down list. The available selections depend on measurement mode and active Q-RPT type.

Gauge mode: Min=0

Absolute mode: Min=0 or ATM

Negative Gauge mode, Axxx Q-RPT: Min=0

Negative Gauge mode, BGxxx Q-RPT : Min=0 or -Max

Control at Target: From the drop down list, **Yes** to maintain pressure control at Max Target during the Delay time before decreasing pressure. **No** uses a fast ramp and aborts near the target without controlling at the target.

Delay at Target: Enter the time at Max Target and Min Target before continuing with the next step in the sequence. If Control at Target is set to **Yes** then pressure control will be maintained during this delay. If Control at Target is set to No then pressure control will abort and the PPC4 will be idle during this delay.

[Back] returns to the AutoTest screen. **[Esc]** or **ESC** exits the Exercise menu and returns to the Main Run Screen. **[OK]** accepts the settings and proceeds to the Exercise Run Screen.

The Exercise Run Screen displays the Cycle count (cycle in progress / total number of cycles) and the Time at Ready which counts down from the Delay at Target value to 0.

In the Exercise Run Screen, **[Start]** to begin the Exercise sequence. At any time, **[Stop]** to abort the sequence and reset the counter. **[Back]** aborts the sequence and returns to the Exercise entry screen. **[Esc]** or **ESC** aborts the sequence and returns to the Main Run Screen.

When the exercise sequence is complete the PPC4 sounds three two second beeps and returns to the main menu.

5.7.2.2 Quick Test

○ OPERATION

To run a Quick Test sequence, **[Tools], <AutoTest>, Quick Test** from the Main Run Screen.

From the Quick Test screen enter the following:

Max: The maximum test pressure for the sequence. The value must be within the current AutoRange limits (see Section 3.2.8). To change the current AutoRange see Section 5.7.1.

Note

The maximum pressure of the currently available AutoRange is shown in the upper left hand corner of the Quick Test window. See Section 5.7.1.

Min: The minimum test pressure for the sequence.

Step: The step size in % of test sequence span (Max-Min). Test will run with pressure steps of (Max-Min)*Step% with the uneven increment at the Max pressure if applicable.

Direction: Direction of test execution.

Up – starts at Min and ends at Max

Down – starts at Max and ends at Min

Up/Down – sequence runs from Min to Max and back to Min

Down/Up – sequence runs from Max to Min and back to Max

[OK] to accept test settings and continue. [Back] to return to <AutoTest>. [Esc] or **ESC** to exit to the Main Run Screen.

In the next screen enter the following:

Continue Mode: From the drop down list choose User or Timer. If User is chosen the test sequence will proceed to the next target value only after **ENTER** or the knob is pressed. If the Timer is selected then the next test sequence will proceed after the timer value has elapsed.

Timer: The time, in seconds, the pressure will hold at each step if the Timer mode is selected. Timer can be between 1 and 9999 seconds.

[OK] to accept settings and continue to the Quick Test run screen, [Back] to return to the Quick Test setup screen or [Esc] or **ESC** to exit to the Main Run Screen.

In the Quick Test Run Screen, [Start] begins the Quick Test sequence. Once the sequence begins, the Point counter displays current sequence increment / total increments. If the control mode is dynamic (see Section 3.2.2.1), once a *Ready* condition has been achieved (see Section 3.2.3) **▲** and **▼** can be used to adjust the pressure set by the PPC4 until the UUT reaches the cardinal value of the pressure increment using the Jog function (see Section 3.2.20). In User Continue Mode, once the UUT has reached the cardinal value of the pressure increment then use [Next Point]. In Timer Continue Mode, once the pressure is *Ready*, the sequence will proceed automatically after the delay has elapsed.

Note

While the Quick Test is running, the upper half of the display is exactly the same as the Main Run Screen, displaying the Ready indicator, control indicator, measured pressure, target pressure and pressure rate of change. See Section 5.1.

At any time during the sequence, [Previous Point] causes the PPC4 to go back and retake the previous test point. [Next Point] stops the current point and moves to the next test point in the sequence. On the last test point [Stop] is shown instead of [Next Point]. Completing the last point or [Stop] moves to the Quick Test summary screen.

[Back] aborts the sequence and returns to the previous screen. [Esc] or **ESC** aborts the sequence and returns to the Main Run Screen.

Once the test is complete the results are shown on the Quick Test summary screen. The pressure values from the PPC4 are shown with the respective sequence numbers. If there are more than eight points in the test then a scroll bar is shown.

[Back] returns to the Quick Test Run Screen to start the same test sequence again. [Esc] or **ESC** returns to the Main Run Screen.

5.7.2.3 Advanced Test

The Advanced Test provides the opportunity to create, save and run up to 20 test sequences with greater flexibility than with Quick Test.

○ OPERATION

To run, edit or delete an Advanced Test sequence, [Tools], <AutoTest>, **Advanced Test** from the Main Run Screen.

At the top of the Advanced Test screen is the **Test** field, with a drop down list of previously saved Advanced Test sequences. To run a test from this list, select the test.

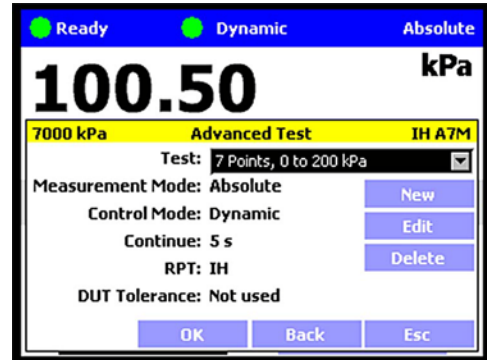

Note

The summary information of the test is then shown in the **Test:** field as well as in the information fields on the left side of the screen. Checking this information helps to ensure that the correct sequence is being run and that it will not exceed the maximum pressure of the UUT.

From the Advanced Test main screen, selections include:

- [New] Create a new Advanced Test.
- [Edit] Edit and existing Advanced Test.
- [Delete] Deletes the active Advanced Test
- [OK] Runs the active Advanced Test
- [Back] Returns to the [Tools], <AutoTest> tab
- [Esc] or **ESC** exits to the Main Run Screen

5.7.2.3.1 New Test

[Tools], <AutoTest>, **Advanced Test**, [New] initiates creation of an Advanced Test. The first step in creating an Advanced Test is to create an AutoRange for the test span (See Section 5.7.1).

In the AutoRanger screen there are fields to select or enter values.

- Unit:** The unit of measure associated with the AutoRange.
- Mode:** The measurement mode associated with the AutoRange. The choice of measurement modes offered reflects all the Q-RPT types available (Axxx, Gxxx, BGxxx) in the PPC4 system, not just the active Q-RPT.
- Full Scale:** Enter the full scale pressure value in the unit of measure specified in the Unit field and [OK] to accept. If the full scale pressure entered cannot be covered by any of the Q-RPTs available, an error window is displayed (“No suitable RPTs found”). If the full scale pressure can be covered by an available Q-RPT, the entry is accepted.

Use UUT Tolerance: If this field is “Yes” the UUT Tolerance is used to determine the PPC4 resolution and hold limit settings for the resulting AutoRange. If this field is “No” the resolution and hold limit settings for the resulting AutoRange are determined based on the AutoRange full scale and the active selected Q-RPT.

UUT Tolerance: If enabled, the tolerance of the device under test, in % of AutoRanged span, associated with the resulting AutoRange. Used to determine control limits and to determine pass/fail for test results.

[OK] from the AutoRanger screen enters the AutoRange Confirmation screen, where the specified Full Scale, Unit, Mode and UUT Tolerance are listed in addition to the selected RPT. Selecting the **RPT** drop down list shows all available RPTs that can cover the specified AutoRange. If an RPT other than the one selected is desired, it may be chosen from this list. **Back** to return to the AutoRanger screen. [Esc] or **ESC** exits to the Main Run Screen.

Note

If an external Q-RPT that should be available is not being selected by AutoRange, use [RPT] to search for Q-RPTs and determine whether external Q-RPTs have been properly connected and initialized (see Section 2.3.6).

[OK] from the AutoRange Confirmation screen creates the range and continues, [Back] returns to the previous screen. [Esc] or **ESC** exits to the Main Run Screen.

Continuing enters the Advanced Test editing screen where test values are listed on the left and test sequence editing buttons are given on the right.

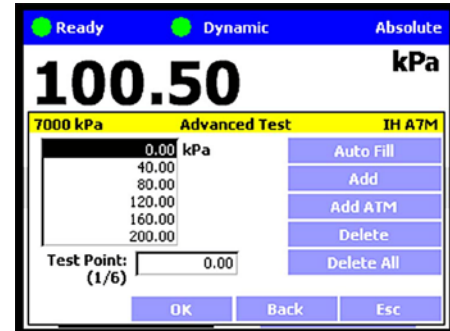

Note

The pressure unit for the test points is shown to the right of the test value list and may be different from the current, active unit of measure (see Section 3.2.10).

To edit the numerical value of a test point:

Select the entry in the test value list and *Enter* or **ENTER** to access the list.

Select the test point to edit.

Enter or **ENTER** again to choose the point and exit to the Test Point field.

The counter shows which test point is active (test point number / total number of points).

Edit the value of the test point with the numeric keypad.

Enter or **ENTER** to accept the edited value.

[Auto Fill]: This function creates a test sequence of uniform steps. From the next screen enter the following:

Max: The maximum test pressure for the sequence. The value must be within the newly created AutoRange limits. **[Back]**, **[Back]** to edit this AutoRange.

Min: The minimum test pressure for the sequence.

Step: The step size in % of test sequence span (Max-Min). Test will run with pressure steps of (Max-Min)*Step% with the uneven increment at the Max pressure if applicable.

Direction: Direction of test execution.

Up – starts at Min and ends at Max

Down – starts at Max and ends at Min

Up/Down – sequence runs from Min to Max and back to Min

Down/Up – sequence runs from Max to Min and back to Max

[OK] to accept and activate the Auto Fill settings and return to the Advance Test edit screen. **[Back]** to return to the previous screen without making changes. **[Esc]** or **ESC** to exit and return to the Main Run Screen without saving the test.

[Add]: Adds a Test Point below the currently active (highlighted) point in the test list. The new point is created with the same numerical value as the point above it. The value of the new test point can be edited immediately using the numeric keypad.

To add another point below the first, **[Add]** again.

To add another point at a different location, *Select* the entry in the test value list, *Enter* and *Select* the point that will be above the new point. *Enter* then **[Add]** as before.

[Add ATM]: Adds an atmospheric (vent) point below the currently active point in the test list. The new point value is shown as “ATM”.

[Delete]: Deletes the currently active point in the test list. After deleting the point below the deleted point becomes the active point.

[Delete All]: Deletes all of the points in the test list.

[OK] to continue to the next screen. **[Back]** to return to the AutoRanger. **[Esc]** or **ESC** to exit and return to the Main Run Screen.

Continuing from the Advanced Test setup screen to the next screen. Enter the following:

Continue Mode: From the drop down list choose User or Timer. If User is chosen the test sequence will proceed to the next target value only after **ENTER** or the knob is pressed. If the Timer is selected then the next test sequence will proceed after the timer value has elapsed.

Timer: The time, in seconds, the pressure will hold at each step if the Timer mode is selected. Timer can be between 1 and 9999 seconds.

Control Mode: Choose Static or Dynamic control mode (see Section 3.2.2).

[OK] to accept the new Advanced Test and return to the Advanced Test main screen, [Back] to return to the previous screen or [Esc] or  to exit to the Main Run Screen.

5.7.2.3.2 Edit Test

[Tools], <AutoTest>, Advanced Test, [Edit] opens the currently selected Advanced Test sequence for editing.

Note

- Editing an Advanced Test sequence follows the same steps as creation of a New Test (See Section 5.7.2.3.1), starting with the AutoRange.
- Editing any field in the AutoRanger screen will cause the test points to be regenerated automatically as default values. Any changes to the AutoTest sequence need to be made from the Advanced Test editing screen.

After all changes have been made, from the Advanced Test “Continue mode” screen, [OK] to accept and save the edited Advanced Test. [Back] to return to the previous screen. [Esc] or  to exit and return to the Main Run Screen without making a change to the selected Advanced Test.

5.7.2.3.3 Delete Test

[Tools], <AutoTest>, Advanced Test, [Delete] deletes the currently active Advanced Test.

Caution



Be sure to select the test that is to be deleted before using [Delete]. Verify that the test sequence listed in **Test:** represents the test that is to be deleted. Once a test is deleted it cannot be retrieved and must be recreated.

5.7.2.3.4 Run Advanced Test

[Tools], <AutoTest>, Advanced Test, [OK] runs the selected AutoTest.

Note

Before running an advanced test, first select from the [Test] drop down menu the Advanced Test that is to be executed. If the desired test is not present then a new test will need to be created (See Section 5.7.2.3.1).

In the Advanced Test Run Screen, [Start] begins the Advanced Test sequence. Once the sequence begins, the Point counter displays current sequence increment / total increments. If the control mode is dynamic (see Section 3.2.2.1), once a *Ready* condition has been achieved (see Section 3.2.3)  and  can be used to adjust the pressure set by the PPC4 until the UUT reaches the cardinal value of the pressure increment using the Jog function (see Section 3.2.20). In User Continue Mode, once the UUT has reached the cardinal value of the pressure increment then use [Next Point]. In Timer Continue Mode, once the pressure is Ready, the control will sequence will proceed automatically after the delay has elapsed.

Note

While the Advanced Test is running, the upper half of the display is exactly the same as the Main Run Screen, displaying the Ready indicator, control indicator, measured pressure, target pressure and pressure rate of change. See Section 5.1.

At any time during the sequence, **[Previous Point]** causes the PPC4 to go back and retake the previous test point. **[Next Point]** stops the current point and moves to the next test point in the sequence. On the last test point **[Stop]** is shown instead of **[Next Point]**. Completing the last point or **[Stop]** moves to the Advanced Test summary screen.

[Back] aborts the sequence and returns to the previous screen. **[Esc]** or **ESC** aborts the sequence and returns to the Main Run Screen.

Once the test is complete the results are shown on the Advanced Test summary screen. The pressure values from the PPC4 are shown with the respective sequence numbers. If there are more than eight points in the test then a scroll bar is shown.

Note

Select and Enter the highlighted number in the list to scroll.

If UUT Tolerance is used (specified in the AutoRanger screen, see Section 5.7.2.3.1) then the summary screen will also include “pass”, “fail” or “ATM” for each point in the sequence. The criteria for pass/fail assumes that the UUT is adjusted to the cardinal values of each test point and calculates an error based on the difference between the test point and the PPC4 reading.

Pass: The difference between the PPC4 pressure and the UUT is less than or equal to the UUT Tolerance, expressed as a percent of AutoRange span.

Fail: The difference between the PPC4 pressure and the UUT is greater than the UUT Tolerance.

N/A: Targets of 0 and Vent do not have pressure adjustment for UUT cardinal point. Pass/Fail determination is not applicable.

[Back] returns to the Advanced Test Run Screen to start the same test sequence again. **[Esc]** or **ESC** returns to the Main Run Screen.

5.7.3 Pressure

The **[Tools], <Pressure>** tab contains the utility pressure functions Purge and Leak Test. The **[Tools], <Pressure>** screen displays the Purge enable status and the results of the last successful Leak test. If the Purge function is enabled (see Section 5.7.12.3) then the display shows **<Purge: On>**. If the Purge function is disabled then the display shows **<Purge: Off>**. The Leak Test results show the results of the last successful Leak Test in rate (Units/s) and pressure change in the Units active at the time of the test.

5.7.3.1 Purge

○ PURPOSE

To execute the PPC4 test system Purge function using the optional Self Purging Liquid Trap (SPLT). Purge is used to collect and exhaust liquid contaminants from the device or system under test before they reach the PPC4 (see Section 3.2.17).

○ OPERATION

Note

For the Purge function to execute, the function must have been enabled using [Settings], <Internal>, Purge, On (see Section 5.7.12.3) and an optional Self Purging Liquid Trap (SPLT) must be installed in the test line (see Section 2.3.7.1). When the purge function is enabled the Main Run Screen will show **Purge: On** for the Purge shortcut field.

To purge the UUT and/or system under test using the PURGE function, proceed as follows:

- ❶ **Connect the system or device under test (UUT) to the PPC4 TEST(+) port:**
Make sure the optional SPLT is properly installed between the UUT and the PPC4, TEST(+) port including the electrical connection for the PPC4 DRIVER connector to the SPLT valve.
- ❷ **Set the purge pressure:** Use the PPC4 direct pressure control keys (see Section 3.2.1) or automated pressure control (See Section 5.5.1) to the set purge pressure. The purge pressure should be roughly the UUT full scale or 1 MPa (150 psi), whichever is lower. Avoid activating the purge function at pressure > 1 MPa (150 psi).
- ❸ **Purge, [Start] or [Tools], <Pressure>, Purge, On from the Main Run Screen:**

Note

ESC or [Stop] at any time during execution of the purge routine causes the purge function to abort and returns to the Main Run Screen.

PPC4 controls pressure down to less than 700 kPa (100 psi), stops control and displays <Preparing to purge> for five seconds. After the five second delay, PPC4 opens the SPLT exhaust valve and displays <Purging...>.

Once the pressure reaches less than 20 kPa (3 psi) gauge or 110 kPa (16 psi) absolute, PPC4 opens its internal vent valve and returns to the Main Run Screen in its normal vented condition.

The PPC4 will beep three times to signal the completion of the Purge routine.

- ❹ Repeat steps ❷ and ❸ until no liquids or other contaminants are expelled when the SPLT exhaust valve opens.

5.7.3.2 Leak Test

○ PURPOSE

To run an automated leak check routine that determines the leak rate of the system connected to the PPC4 TEST(+) port (see Section 3.2.18).

○ OPERATION

To run a leak check, first set the pressure to the desired leak check pressure using the direct pressure control keys (see Section 3.2.1) or automated pressure control (See Section 5.5.1)

To access the Leak Test function, use [Tools], <Pressure>, Leak Test from the Main Run Screen. The shortcut for Leak Test is **Leak Test** on the Main Run Screen.

Edit the leak test time, in seconds (minimum 2, maximum 999). **ENTER** or Enter to accept the value. [Start] to begin the test.

[Stop] aborts the running leak test. [Start] once more restarts the leak check timer. At any time during leak test [Esc] or  aborts and returns to the Main Run Screen.

While the leak test is in process the Average Rate and the total change in pressure (dP) are displayed using the currently active unit of measure, with values updated throughout the test. When the leak check timer countdown has finished, the result is shown in the displayed values for Average Rate and dP.

[Start] to run another leak test. [Back] to return to [Tools], <Pressure>. [Esc] or  to exit to the Main Run Screen.

[Tools], <Pressure> displays the results of the most recently completed leak check as well as the Purge enable status. The Leak Test results show the results of the last successful Leak Test in rate (Units/s) , pressure change in the Units and the Q-RPT active at the time of the test. If NO leak check data is stored (i.e., if the PPC4 has never run a leak test or a reset has cleared previous leak test results), <Pressure> displays <Leak Test: None>.

5.7.4 Drivers

○ PURPOSE

To control the output signals of PPC4's 8 channel, 12 V external drivers (see Section 3.2.23).

Note

See Section 9.1 for driver specifications and pin-outs.

○ OPERATION

[Tools], <Drivers> opens the driver control screen. Select the driver to change. Enter or  to change state (On/Off).

When a driver is On, voltage is applied. ●

When a driver is Off, voltage is not applied. ○

Caution

The PPC4 Purge function makes use of the valve driver option. Valve driver number 8 is used to actuate the SPLT exhaust valve. The SPLT exhaust valve is actuated when performing the Purge function and in the background every time the PPC4 Vent function is used. When making use of valve drivers, note that when the Purge function is enabled, valve driver number 8 will be actuated independently of user initiated valve driver commands (see Section 3.2.17).

[Esc] or  exit to the Main Run Screen.

5.7.5 System

Use [Tools], <System> to access [Run AutoZ](#), [Control Configuration](#) and [Resets](#).

5.7.5.1 Run AutoZ

○ PURPOSE

Run AutoZ with an absolute mode Q-RPT in order to compensate for possible changes in Q-RPT zero between full recalibrations (see Section 3.2.22).

○ OPERATION

Note

- Run AutoZ applies only to Axxx Q-RPTs in absolute measurement mode. In gauge and negative gauge measurement modes, AutoZ is run automatically whenever the PPC4 is in the Vent condition (see Section 3.2.14).
- In order to Run AutoZ, AutoZ must be On. To turn AutoZ On or Off use [Settings], <More >>, <Calibration>, xx RPT, <AutoZ>, Absolute AutoZ (where xx RPT could be Hi RPT or Lo RPT). See Section 7.2.7.2.

To open the Run AutoZ menu from the Main RunScreen use [Tools], <System>, Run AutoZ. The shortcut to Run AutoZ is AutoZ on the Main Run Screen. If the current measurement mode is gauge or negative gauge, a message indicating that AutoZ cannot be run manually in gauge mode is displayed. If AutoZ is OFF for the active Q-RPT then an error message will indicate that AutoZ is not available.

Note

Allow the PPC4 to stabilize at atmospheric pressure and ambient temperature for 10 to 15 minutes before running AutoZ.

The Run AutoZ screen shows a numeric entry field for $P_{std,0}$, the reference pressure. This is the pressure reading of the reference device used for comparison. Note that the reference pressure must be entered in the same unit of measure as the PPC4 pressure. The current PPC4 pressure is shown for reference on the second line.

Note

- While the value of Reference ($P_{std,0}$) is entered in the current pressure unit of measure, the value of P_{offset} is always in Pascal (Pa).
- If running AutoZ results in a value of P_{offset} that is greater than ± 0.005 % FS of the span of the Q-RPT that is being AutoZeroed, the Q-RPT and/or the reference used as the source of $P_{std,0}$ may be out of tolerance or the AutoZ process may have been faulty. Before activating a new P_{offset} greater than ± 0.005 % FS of the active Q-RPT, check to be sure that both the Q-RPT and the reference were in good working order, properly vented to stable atmospheric pressure, at the same height, and reading in the same pressure units when AutoZ was run.
- When running AutoZ, if a Head correction is currently active (see Section 3.2.16), it is momentarily disabled to avoid “zeroing out” the head value.

5.7.5.2 Control Configuration

○ PURPOSE

This function is considered part of PPC4 maintenance and is therefore covered in the maintenance section of this manual. See Section 7.5.

○ OPERATION

This function is considered part of PPC4 maintenance and is therefore covered in the maintenance section of this manual. See Section 7.5.2.

5.7.5.3 Reset

○ PURPOSE

To reset various PPC4 settings to default or factory values. Use [\[Tools\]](#), [<System>](#), [Resets](#) to access the Reset functions (see Section 3.2.25).

Caution

PPC4 reset functions will change current settings to factory defaults. These may include settings vital to PPC4 operation and affecting the calibration of the quartz reference pressure transducers (Q-RPTs). Reset functions should only be used by qualified personnel with knowledge of reset consequences. Reset functions should not be used experimentally.

5.7.5.3.1 Settings

○ PURPOSE

Sets most general operating parameters back to default values. Does not affect calibration coefficients, remote interfaces or AutoRange ranges (see Section 3.2.25.1).

○ OPERATION

From the Main Run Screen use [\[Tools\]](#), [<System>](#), [Reset](#), [Settings](#).

[\[Yes\]](#) to activate changes (perform the reset). The PPC4 will cycle power to complete and return to the Main Run Screen. [\[No\]](#) to make no changes and return to the Reset screen.

5.7.5.3.2 Units

○ PURPOSE

Resets Unit selections to factory defaults (see Section 3.2.25.2).

○ OPERATION

From the Main Run Screen use [\[Tools\]](#), [<System>](#), [Reset](#), [Units](#).

[\[Yes\]](#) to activate changes (perform the reset). The PPC4 will cycle power to complete and return to the Main Run Screen. [\[No\]](#) to make no changes and return to the Reset screen.

5.7.5.3.3 AutoTest

○ PURPOSE

Resets Exercise, Quick Test and Advanced Test to default characteristics (see Section 3.2.25.3).

○ OPERATION

From the Main Run Screen use [\[Tools\]](#), [<System>](#), [Reset](#), [AutoTest](#).

[\[Yes\]](#) to activate changes (perform the reset). The PPC4 will cycle power to complete and return to the Main Run Screen. [\[No\]](#) to make no changes and return to the Reset screen.

5.7.5.3.4 Calibration

Caution

The Reset Calibration function will reset Q-RPT, utility sensor and barometer calibration coefficients and settings and reset AutoZ values to zero. This will change the PPC4 calibration and could cause it to make out of tolerance measurements.

Clears all user values affecting the calibration of Q-RPTs, utility sensor and the on-board barometer. Does not clear factory coefficients (see Section 3.2.25.4).

○ OPERATION

From the Main Run Screen use [\[Tools\]](#), [<System>](#), [Reset, Calibration](#)

[\[Yes\]](#) to activate changes (perform the reset). The PPC4 will cycle power to complete and return to the Main Run Screen. [\[No\]](#) to make no changes and return to the Reset screen.

5.7.5.3.5 Reset All

Caution

The Reset All function clears and deletes large amounts of user defined information including critical calibration data.

Combines all resets in one global reset command that clears the entire user section of non-volatile memory returning PPC4 to the “as delivered” condition except the ID function and the security level password. (See Section 3.2.25.5).

○ OPERATION

From the Main Run Screen use [\[Tools\]](#), [<System>](#), [Reset, Reset All](#)

[\[Yes\]](#) to activate changes (perform the reset). The PPC4 will cycle power to complete and return to the Main Run Screen. [\[No\]](#) to make no changes and return to the Reset screen.

5.7.6 Pressure

Use [\[Settings\]](#), [<Pressure>](#) to access [Pressure Unit](#), [Measurement Mode](#), [Head](#) and [Resolution](#). The [\[Settings\]](#), [<Pressure>](#) tab displays the current values of each of these four settings. *Select* and *Enter* to edit settings.

5.7.6.1 Pressure Unit

○ PURPOSE

To select the unit of pressure in which PPC4 displays pressure values.

Note

For information on selecting the measurement mode (absolute, gauge, negative gauge), see Section 5.7.6.2.

○ OPERATION

[\[Settings\]](#), [<Units>](#), [Pressure Unit](#) opens the Pressure Unit screen. The shortcut for Pressure Unit is the Unit field on the Main Run Screen. The Pressure Unit screen has three tabs.

<Favorites> Lists the most recently selected units.

<All Units> Lists all available units.

<User Units> Lists units defined by the user.

[Back] to return to the Main Run Screen, **[Esc]** or **ESC** to exit to the Main Run Screen.

Note

The pressure measurement unit selected is range specific. When in a given range, all functions and settings are represented in the current measurement unit for that range. However, certain internal and/or metrological functions (e.g., Q-RPT calibration coefficients) are always represented in Pa regardless of the active range unit of measure. In addition, when the active unit is an altitude unit, the range and upper limit indications are in kPa if the unit is meters (m) and psi if the unit is feet (ft).

5.7.6.1.1 Favorites

The Favorites tab in the Pressure Unit menu lists up to ten of the most recently used units for quick and easy selection. *Select* and *Enter* the unit selection. After the unit has been chosen the PPC4 returns to the Main Run Screen with the new unit active.

Note

Every time a new unit is selected from the All Units list (see Section 5.7.6.1.2) the new unit is added to Favorites.

[Reset] to erase the list of Favorites, **[Back]** to return to **<Pressure>**, **[Esc]** or **ESC** exit to the Main Run Screen without making a change.

5.7.6.1.2 All Units

If the desired unit has not been used recently and is not in the Favorites list, then **<All Units>** can be selected. The All Units tab provides a scrolling list of all selectable units. These include the five user defined units (see Section 5.7.6.1.3).

First *Enter* the scrolling list then scroll through and *Select* the desired unit of measure. **ENTER** or *Enter* to select, **ESC** to exit the menu.

Note

Units representing a water column (inches/meters/millimeters of Water) are all represented with a selection of temperatures from which to calculate density. The temperature is part of the unit definition. Choose from 4 °C, 20 °C or 60 °F. For example, the unit for inches of water at 20 ° is inH2O@20C.

[Back] to return to the **<Pressure>** tab, **[Esc]** or **ESC** exit to the Main Run Screen without making a change.

5.7.6.1.3 User Units

If a unit of measure is needed that is not among the predefined units then up to five user defined units may be created. To create a user defined unit first the conversion from the new unit to Pascal (Pa) must be specified. In order to edit a

user defined unit, select **[Settings]**, **<Pressure>**, **Pressure Unit**, **<User Units>**. Then *Select* which of the five User Defined units to edit.

To edit the name using the text editing screen, *Select* and *Enter* the Unit Name field. *Selecting* and *Entering* a letter allows brings up the character drop down list. *Enter* to accept a replacement character, **ESC** to exit the drop down list. Scroll left and right by using **[<<]** and **[>>]**. **[Delete]** to erase the current character.

[OK] to accept and return to the Unit edit screen, **[Back]** to reject changes and return to the Unit edit screen, **[Esc]** or **ESC** to reject changes and exit to the Main Run Screen.

Enter the appropriate value for the number of Units/Pa in the second field of the User Defined unit screen. For example, the unit kiloPascal (kPa) would have Units/Pa equal to 0.001.

[OK] to accept and return to the Main Run Screen, **[Back]** to reject changes and return to the **<User Units>** tab, **[Esc]** or **ESC** exit to the Main Run Screen without making a change.

5.7.6.2 Measurement Mode

○ PURPOSE

To set the measurement mode (absolute, gauge or negative gauge) for the active range (see Section 3.2.11).

○ OPERATION

[Settings], **<Pressure>**, **Measurement Mode** brings up the Measurement Mode screen with the available mode selections. The shortcut to Measurement Mode is the measurement mode field from the Main Run Screen (see Figure 11). *Select* and *Enter* to change the selected mode and return to the Main Run Screen with the new mode active.

If an Axxx Q-RPT or a utility sensor is active, all three measurement modes are supported: absolute, gauge and negative gauge. If absolute and negative gauge modes are OFF then only gauge mode is available. (see Section 7.2.5).

If a Gxxx Q-RPT is active, only gauge measurement mode is available. **[Settings]**, **<Pressure>**, **Measurement Mode** results in a message: **<Only current measurement mode is available>**.

[Back] to return to **<Settings>**. **[Esc]** or **ESC** to return to the Main Run Screen without making a change.

Note

- **Certain PPC4 settings, including AutoZ ON/OFF (see Section 3.2.22) are range AND measurement mode specific. See Table 4 for a listing of settings and what they are specific to.**
- **Absolute and negative gauge modes on an Axxx Q-RPT can be turned OFF in the calibration function (see Section 7.2.5). When absolute and negative gauge modes are turned OFF for an Axxx Q-RPT, only gauge mode can be activated.**

5.7.6.3 Head

○ PURPOSE

To cause a pressure fluid head correction to be added or subtracted to the pressure measured by the PPC4 reference pressure transducer in order to

predict the pressure at a height other than the PPC4's reference level (see Section 3.2.16).

Note

Use of the Head function to ensure in tolerance measurements is most important in low absolute pressure ranges. Specifying the head height within ± 3 in. (7.5 cm) is adequate to ensure that, even in the worst case, the uncertainty on the head correction will be insignificant relative to the tolerance on the measurement.

○ OPERATION

[Settings], <Pressure>, Head opens the Head screen. The shortcut to Head is **Head**: on the Main Run Screen (see Figure 11). In this screen edit:

Height: The height of the UUT or measured pressure above the reference level of the PPC4.

The reference height of the PPC4 pressure measurement is the middle of the PPC4 TEST port. The head height should be entered as a positive value if the device or system under test is higher than the PPC4 and negative if it is lower.



Unit: The unit of measure of the height measurement (centimeters or inches)

Medium: The fluid medium in the test connection between the TEST(+) port and the UUT or measured pressure.

After editing values, **[OK]** to accept changes and return to the Main Run Screen. **[Back]** to return to **<Pressure>**. **[Esc]** or **ESC** exit to the Main Run Screen without making a change.

Note

- The currently active head values can be seen on the **Head** shortcut on the Main Run Screen (see Figure 11). The height, unit and medium are shown. For example: **Head: 0 cm, N2** represents no head correction because the height is equal to 0.
- The Head function is NOT range specific. The Head ON or OFF status remains the same as ranges are changed. Edits made to the head settings are independent of active range or Q-RPT.
- When using external Q-RPTs in RPM4, it is recommended that the RPM4 head height be adjusted to the reference level of the PPC4 before connecting the RPM4. Then, the normal PPC4 reference level to UUT head corrections can be made for all the Q-RPTs, whether internal or external to PPC4.

5.7.6.4 Resolution

○ PURPOSE

To set the resolution with which measured pressures and other pressure indications and settings are displayed.

○ OPERATION

[Settings], <Pressure>, Resolution opens the Resolution screen. The shortcut to Resolution is the measured pressure field from the Main Run Screen (see Figure 11). In the resolution window choose from the available choices between 1.0% of full scale and 0.0001% of full scale. The currently active resolution value is shown in gray.

[Back] to return to <Pressure>. [Esc] or **ESC** to exit to the Main Run Screen without making a change.

Note

- The resolution setting is range specific. A resolution setting made in one range does NOT affect other ranges.
- The measured pressure resolution is fixed for altitude units at 1 m in meters and 1 ft in feet.
- The maximum resolution setting is limited in AutoRange ranges that are less than 10% of the Q-RPT default full scale.
- The maximum resolution setting when using a utility sensor is 0.001% of utility sensor span.

5.7.7 Preferences

Use [Settings], <Preferences> to access **Screen Saver, Sounds, Time, Language** and **Security**. The [Settings], <Preferences> tab displays the current values of each of these settings. *Select* and *Enter* to edit settings.

5.7.7.1 Screen Saver

○ PURPOSE

To adjust the PPC4's Screen Saver settings (see Section 3.2.26.1).

○ OPERATION

[Settings], <Preferences>, Screen Saver opens the Screen Saver screen. Edit **Time**, from 10 minutes to 8 hours. If Time is set to Off then the screen saver function will be disabled and the screen will remain on as long as the PPC4 power is on. Editing **Style** chooses the display when the screen saver is activated. The choices include "Moving Pressure" which displays the current measured pressure, moving on the screen, and "DHI" (the DHI logo).

[OK] to accept and return to the Main Run Screen. [Back] to return to <Preferences>. [Esc] or **ESC** to return to the Main Run Screen without making a change.

5.7.7.2 Sounds

○ PURPOSE

To adjust or suppress the PPC4 key press sound (see 3.2.26.2).

○ OPERATION

[Settings], <Preferences>, Sounds opens the Sounds screen. From here choose **None, Low, Medium** or **High** for the valid key press frequency. The currently active frequency is shown in gray.

Choose **None** to suppress the key press tone.

Select and *Enter* to choose the desired sound and return to the Main Run Screen.

[Back] to return to <Preferences>. [Esc] or **ESC** return to the Main Run Screen without making a change.

5.7.7.3 Time

○ PURPOSE

To view and edit the PPC4 internal time and date settings (see Section 3.2.26.3).

○ OPERATION

Note

The PPC4 date and time are set to United States Mountain Standard Time in the final test and inspection process at the factory. If desired, use the Time and Date functions to set your local time and date.

The PPC4 has an internal real time clock that is used for date and time stamping calibrations and internal logs.

[Settings], <Preferences>, Time accesses the PPC4 date and time settings. Select and edit these fields to set the time as desired. The year is in year/month/day format (yyyymmdd). Time may be displayed in either a 12 hour (AM/PM) or 24 hour format, set by editing Time Style. If Time Style is 24 hour then AM/PM is blank.

5.7.7.4 Language

○ PURPOSE

To specify the language for PPC4 Advanced Interface display, headings, menus and screens (see 3.2.26.4).

○ OPERATION

[Settings], <Preferences>, Language opens the Language screen. Select the preferred language for on screen display and *Enter*. The currently active language is shown in gray.

Select a language and *Enter* or **ENTER** to change languages and return to the Main Run Screen. [Back] to make no change and return to <Preferences>. [Esc] or **ESC** to make no change and exit to the Main Run Screen.

Note

- The language selection affects to headings, buttons, tabs, field names and on-screen messages. Numeric displays, including pressure units and DHI trademarked terms, such as AutoRange, are always in English.
- Remote commands and their responses are always in English, regardless of language setting.

5.7.7.5 Security

○ PURPOSE

To set user protection levels to restrict access to certain functions and to edit the password required for changing user levels (see Section 3.2.26.5).

○ OPERATION

[Settings], <Preferences>, Security accesses the PPC4 Security screen. PPC4 is delivered with no active password and access to the Security screen is open. The security level is set to Low. Security levels can be changed freely until a password has been created.

To change the Security level, access the security screen, [Settings], <Preferences>, Security. If there is a password in place, the Password screen will be displayed. Enter the password at the prompt "Enter Password:". If no password has been entered the Security screen will be displayed immediately, bypassing the Password screen.

Note

At the bottom left of the Password entry screen is a code (SN: sss-nnnn). The first part (sss) is the PPC4 serial number. The second part (nnnn) is a number that is changed each time the secondary password is used (see 3.2.26.5).

Select and Enter a Security from the choices, Off, Low or High (see Table 11 for function access affected by the security level).

Entering a choice makes the change and returns to the Main Run Screen. [Back] returns to <Preferences> without making a change. [Esc] or  exit to the Main Run Screen without making a change.

5.7.7.6 Edit Security Password

[Edit Password] from Security opens the password editing screen. Passwords can be up to six numbers in length and cannot start with a zero. If <0> is entered, the password is made inactive and the user will not be required to enter a password to access the user level menu. This condition, with a security level of Low, is the factory default.

Caution

Once a password has been entered, the user level cannot be changed without reentering the password or the secondary password.

Note

The factory secondary password is available in case the user's password has been misplaced or forgotten. It can be obtained by contacting a DHI Authorized Service Center (see Table 36). The factory secondary password is different for all PPC4's and changes each time it is used.

[OK] to accept the change and return to Security. [Back], [Esc] or  exit to Security without making a change.

5.7.8 Control

5.7.8.1 Pressure Limits

○ PURPOSE

To set the upper and lower limit pressure value for a pressure range and measurement mode (see Section 3.2.21).

○ OPERATION

[Settings], <Control>, **Pressure Limits** opens the screen to edit or reset the Upper and Lower Limits.

To modify the upper limit, edit the value, noting the pressure units associated with this value. [OK] to accept changes and return to the Main Run Screen. [Back] to return to <Control> and make no changes. [Esc] or **ESC** to exit to the Main Run Screen and make no changes.

Note

- If the current measurement mode is absolute or gauge, there is an upper limit only. The maximum upper limit is 105 % of AutoRange range or 102 % of default Q-RPT range, whichever is smaller.
- RPM4 with Q-RPT full scale spans below 14 MPa have SDS self defense system to isolate and protect the Q-RPTs. If an external RPM4 SDS pressure rating is less than the PPC4 maximum pressure then a warning will be displayed on the PPC4 front panel when the RPM4 is detected. In addition, AutoRanged ranges greater than the SDS rating are not allowed (see Sections 3.2.5, 6.5.4, 3.2.8). In order to create AutoRanged ranges or generate pressures above the SDS pressure rating the RPM4 must be disconnected or the RPM4 SDS must be upgraded to a higher pressure rating. Upgrades may be done at the DH Instruments service center (see Table 36).

If the current measurement mode is negative gauge or the Q-RPT is a BA100K, there is also a lower limit that may be edited. For an Axxx Q-RPT operating in negative gauge mode, the lower limit is –ATM by default. The value may be edited but must be negative. To restore the value of –ATM use [Default Limits].

Note

- The lower limit must be a negative value.
- The default lower limit for a BGxxx Q-RPT in negative gauge mode is the negative equivalent of the upper limit
- The default lower limit for a BA100K Q-RPT in negative gauge mode is 66 kPa (9.6 psi).

[Default Limits] resets the Upper and Lower Limits to the default values for the active Q-RPT and range.

[OK] to accept the changes and return to the Main Run Screen. [Back] to return to <Control> without making changes. [Esc] or **ESC** to exit to the Main Run Screen without making changes.

⚠ Caution

Upper limit values are specific to each range and measurement mode. Be careful not to assume that the upper limit set in one measurement mode will apply to the other. For example, if you set 150 kPa as the upper limit in gauge mode, the upper limit will not be 150 kPa in negative gauge mode of the same range.

Note

Upper limits are always specified and displayed in the current pressure unit except for altitude units. When in altitude units, upper limits are expressed in kPa if the altitude unit is meters (m) and psi if the altitude unit is feet (ft).

5.7.8.1.1 Over Pressure Function

In addition to the UL function, PPC4 has an over pressure function (see Section 3.2.21.1).

To recover from an overpressure condition, correct the overpressure condition and cycle PPC4 power. Be sure to correct the condition that caused the overpressure before cycling power.

5.7.8.2 Pressure Control**○ PURPOSE**

To set the automated pressure control mode for the active range, customize control parameters, activate default control parameters (see Section 3.2.2).

○ OPERATION

[Settings], <Control>, **Pressure Control** opens the screen to select the control mode and to set the control limits.

Select **Static** or **Dynamic** to change to that control mode and exit to the Main Run Screen. The shortcut to **Pressure Control** is the **control mode** indicator on the Main Run Screen (see Figure 11).

Select [**Limits**] from the Pressure Control screen to adjust or view the Control Parameters.

Note

Control mode setting is range specific. A change in control mode made while in one PPC3 range does NOT affect the control mode setting in other ranges.

5.7.8.2.1 Custom Control Parameters (Limits)**○ PURPOSE**

To view active pressure control parameters and/or set custom control parameters (see 3.2.2).

○ OPERATION

To view active control parameters and/or set custom control parameters, use [Settings], <Control>, **Control Limits** from the Main Run Screen. Alternatively

[Limits] from the [Settings], <Control>, Pressure Control screen or from the control mode shortcut open this screen as well.

Three fields are available to edit: Hold Limit, Stability Limit (see Section 3.2.13) and Jog Step (see Section 3.2.20).

Edit the values of the desired parameters, noting the units of measure. [OK] to accept and return to the Main Run Screen. [Back] to return to <Control> with no changes. [Esc] or **ESC** to exit to the Main Run Screen with no changes.

To restore the default values of the three parameters use [Default Limits].

Note

Custom control parameters are range specific. Changes made in one range are stored for that range and are recalled when that range is returned to. Changes made in one range do not affect any other range.

5.7.8.3 Jog Step

○ PURPOSE

Adjust the nominal change in pressure caused by using the jog direct pressure control keys (**▲** and **▼**) (see Section 3.2.20).

○ OPERATION

[Settings], <Control>, Jog Step accesses the Jog Control Limits screen, with the Jog Step field active. Enter a new value in the currently active pressure units.

[OK] to accept the change and return to the Main Run Screen. [Back] to return to <Control> without making changes. [Esc] or **ESC** to exit to the Main Run Screen without making changes.

5.7.9 Remote

○ PURPOSE

To configure the PPC4 COM1, COM2, IEEE-488 (GPIB), or LAN communication ports. To test COM1 and COM2 communications. To select remote programming communications format (see Section 3.2.24).

○ OPERATION

[Settings], <More >>>, <Remote> opens the Remote settings screen.

The remote setting screen varies, depending on the communications hardware installed. The following choices are always available:

COM1: To view and edit COM1 settings (see Section 5.7.9.1).

COM2: To view and edit COM2 settings (see Section 5.7.9.1).

Command Format: To select remote programming command format (see Section 5.7.9.2)

If no optional interface hardware is installed, the following is also displayed.

USB: Indicates front USB port only, not selectable

If the optional IEEE-488 hardware is installed, the following two options are displayed.

IEEE-488: To view and edit IEEE-488 settings (see Section 5.7.9.3)

USB: Indicates front USB port only, not selectable

If the optional Ethernet interface is installed, the following two options are displayed.

USB: Indicates both front and back USB ports, not selectable

Ethernet: To view and edit LAN settings (see Section 5.7.9.4).

5.7.9.1 COM1 and COM2

The COMx ports can be set for specific communications settings. The settings are baud rate, parity, data bits and stop bits. The available options are:

Baud Rate: 1 200, 2 400, 4 800, 9 600, 19 200

Parity: None, Odd or Even

Data Bit: 7 or 8

Stop Bit: 1 or 2

The default is <2400, E, 7,1> for both COM1 and COM2.

Note

The PPC4 looks for an ASCII(13) (carriage return) to terminate a received command but responds with both an ASCII(13) (carriage return) and an ASCII(10) (line feed). There are no options.

See also Sections 6.3.1.1, 6.3.1.2 and 6.3.1.3.

5.7.9.2 Command Format

[Settings], <More >>>, <Remote>, **Command Format** opens the Command Format screen. The highlighted format is the currently active format.

[Settings], <More >>>, <Remote>, **Command Format, Classic** selects the Classic format for commands (see Section 6.4.1)

[Settings], <More >>>, <Remote>, **Command Format, Enhanced** selects the Enhanced format (see Section 6.4.2).

Selecting a format resets the IEEE-488 interface and puts it into an idle state.

See also Section 6.4.

5.7.9.3 IEEE-488

The IEEE-488 port's primary address can be set from 1 to 31 in this screen. The factory default value is 10. Secondary addressing is not used or supported. This address must not conflict with the address of any other device on the same IEEE-488 bus.

Note

The receiving terminating character must be a line feed and EOI. Carriage returns are ignored if received. The PPC4 sends a line feed and asserts the EOI line to terminate a reply. These settings are fixed to agree with IEEE Std. 488.2. If the address is changed, the IEEE interface resets (PON) and becomes idle.

5.7.9.4 Ethernet

[Settings], <More >>>, <Ethernet>, **Setting** allows selection of **DHCP** (for dynamic selection of IP address by the LAN (Local Area Network) or **Manual** for user entered IP address.

[Settings], <More >>>, <Ethernet>, **IP** displays IP address. If **Setting** is “DHCP” then IP is selected by LAN and cannot be edited. If **Setting** is “Manual” then IP address may be entered or edited.

[Settings], <More >>>, <Ethernet>, **UDP** displays the UDP port. Cannot be edited.

[Settings], <More >>>, <Ethernet>, **MAC address** displays the MAC address unique to each PPC4 and contained in the Ethernet module if the Ethernet option is selected. Cannot be edited.

5.7.10 Calibration

○ PURPOSE

To calibrate the PPC4 utility sensor, Hi and/or Lo Q-RPTs and adjust the on-board barometer. This function is considered part of PPC4 maintenance and is therefore covered in the maintenance section of this manual (see Sections 7.2, 7.3, 7.4).

○ OPERATION

See Sections 7.2, 7.3 and 7.4.

5.7.11 Uncertainty

○ PURPOSE

This function is considered part of PPC4 maintenance and is therefore covered in the maintenance section of this manual. See Section 7.2.7.3.

○ OPERATION

This function is considered part of PPC4 maintenance and is therefore covered in the maintenance section of this manual. See Section 7.2.7.3.

5.7.12 Internal

○ PURPOSE

To view, set, adjust, and maintain various aspects of PPC4's internal operation (see Section 3.2.27).

○ OPERATION

[Settings], <More >>>, <Internal> opens the Internal settings screen.

5.7.12.1 ID

○ PURPOSE

To enter an alphanumeric identification (ID) for the PPC4 (see Section 3.2.27.1).

○ OPERATION

[Settings], <More >>>, <Internal>, **ID** opens the ID edit screen.

[OK] to accept and return to the Main Run Screen, [Back] to return to the ID screen without making changes, [Esc] or **ESC** to exit to the Main Run Screen without making changes.

5.7.12.2 Control Reference

○ PURPOSE

To specify whether the PPC4 should automatically determine whether a vacuum source or atmospheric pressure is connected to the **EXHAUST** port and to manually set the **EXHAUST** port condition (see Section 3.2.27.2).

○ OPERATION

[Settings], <More >>>, <Internal>, **Control Reference** opens the Control Reference edit screen.

Setting: Auto or Manual.

Control Reference: Vacuum or Atmosphere

Note

Control Reference is only editable if Setting is set to Manual.

[OK] to accept and return to the Main Run Screen, [Back] to return to the ID screen without making changes, [Esc] or **ESC** to exit to the Main Run Screen without making changes.

5.7.12.3 Purge

○ PURPOSE

To enable or disable the PPC4 Purge function (see Section 3.2.27.4).

○ OPERATION

[Settings], <More >>>, <Internal>, **Purge** opens the Purge screen. The current state of the Purge function is shown in gray. **On** to enable the Purge function. *Select Off* to disable.

[Back] to return to <Internal>, [Esc] to return to the Main Run Screen.

5.7.12.4 Event log

○ PURPOSE

To view and/or clear the PPC4 event log (see Section 3.2.27.5).

○ OPERATION

[Settings], <More >>>, <Internal>, **Event Log** opens the Event log screen if there are any entries in the log. If the word "None" is showing beside Event Log then there are no events (Pmax or Memory faults) in the log. If there are any log entries then the date and time of the last entry are shown.

In the Event Log screen the log entries may be scrolled through. When a given date and time are selected the specific entry is shown above the selection box. If the entry is a Pmax event then the specific RPT is indicated as well as the maximum recorded pressure in units of Pa.

[Clear Log] deletes and resets the entire log. [Back] returns to the <Internal> screen and [Esc] or **ESC** exits to the Main Run Screen.

5.7.12.5 TEST (-) Vent

○ PURPOSE

To cause a PPC4 or external RPM4's Gxxx or BGxxx Q-RPT TEST (-) Vent valve to stay open or closed rather than open and close automatically (see Section 3.2.27.6).

Note

This menu selection is available only when the active Q-RPT is a Gxxx (gauge) or BGxxx (bi-directional gauge) Q-RPT.

○ OPERATION

[Settings], <More >>>, <Internal>, TEST (-) Vent accesses the TEST (-) Vent screen. Selections are Operation and Status.

Operation: Auto or Manual

Status: Open or Closed

Automatic Operation is the default. Manual Operation allows the selection of always Open or always Closed. Status entry is only available if Manual operation is selected.

[Settings], <More >>>, <Internal> to view the settings of the TEST (-) Vent Valve

[OK] to accept and return to the Main Run Screen, [Back] to return to <Internal> without making changes, [Esc] or **ESC** to exit to the Main Run Screen without making changes.

Note

The TEST (-) VENT function setting always applies to the active Q-RPT module, whether the module is internal to PPC4 or in an external RPM4 (see the RPM4 Operation and Maintenance Manual).

Caution

If the PPC4 detects a condition in which it determines there could be a risk of overpressure to the RPT by opening the TEST (-) Vent valve when a Manual Open is requested, a message indicating a DP overpressure risk is displayed. If this message is displayed, return to normal operation, vent the PPC4 and try again.



6. Remote Operation

6.1 Overview

Most of the PPC4 front panel functions can also be executed by commands from a remote computer. The host computer can communicate to the PPC4 using the PPC4 RS232 (COM1), IEEE-488 or Ethernet ports. Remote communications via USB are through the PPC4 API only. See PPC4 API documentation.

Note

The front and optional rear panel USB ports are not directly supported by the remote command set. The PPC4 USB interface is supported by the PPC4 Cockpit (see Section 6.2) as well as the PPC4 API (see PPC4 API documentation for details).

Before writing test code which makes use of PPC4 remote commands, familiarize yourself with its operating principles by reading Section 3 of this manual. Also refer to Sections 6.3.1.3 and Section 6.3.2.1 for testing RS232 and IEEE-488 commands.

6.2 PPC4 Cockpit

6.2.1 Overview

The PPC4 Cockpit is a PC based application that emulates the PPC4 Advanced User Interface (see Section 5), connecting via any of the available I/O options. The PPC4 Cockpit allows a PC, monitor, mouse and keyboard to perform all PPC4 display and data entry functions. All PPC4 Advanced Interface functions are available in the Cockpit. The Cockpit can be used with either the Basic Interface or the Advance Interface versions of the PPC4. Multiple PPC4s can be supported at the same time by opening multiple instances of the Cockpit.

The PPC4 USB port does not support host software in the same manner as the IEEE-488, RS232 or Ethernet ports (see Sections 6.3.1, 6.3.2 and 6.3.4). However communications through the PPC4 USB ports may be accomplished through the PPC4 API. See the API documentation for specifics.

6.2.2 Installation

The PPC4 Cockpit is included in the Software section of the General Accessories CD distributed with the PPC4. The installation is also available in the PC based Software section of www.dhstruments.com under "*pc based free utilities*". The PPC4 USB driver and the PPC4 Cockpit application are installed by the installation program.

6.2.2.1 USB Driver Installation

After a typical installation the front (or optional rear) USB port of the PPC4 can be connected to a PC and used to interface with the PPC4 Cockpit. Some PC configurations will not support the automatic installation of the driver. In this case the driver must be setup manually. Begin the manual driver setup by connecting the PPC4 to the PC using a standard USB cable. The Windows Hardware Wizard will display. Follow the steps below to complete the driver setup process.

- 1 Select the “Advanced” option to select the driver by location. [Next >] to continue.

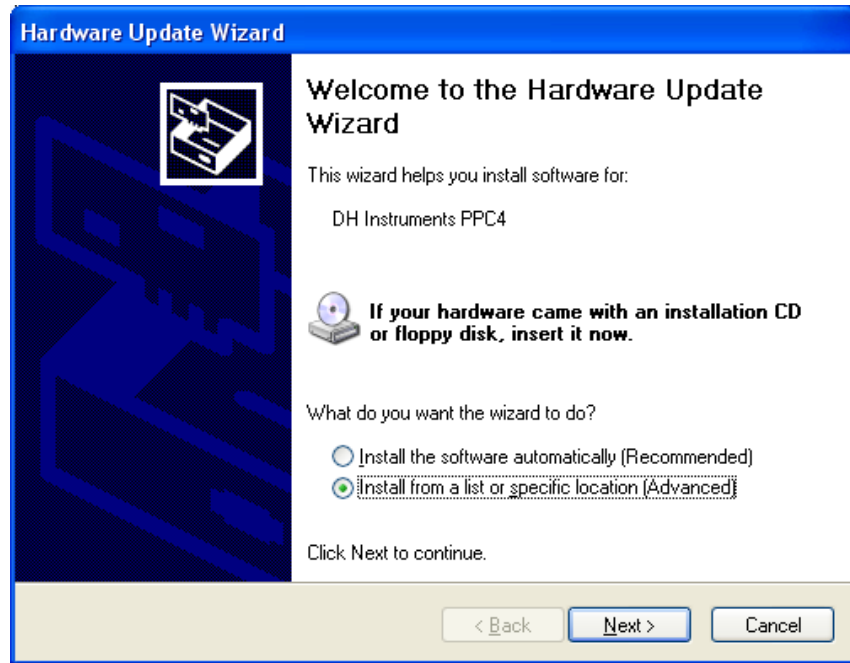

Figure 15. Windows Hardware Wizard

- 2 The driver is located in the \Driver sub directory of the PPC4 Cockpit application. By Default this directory is C:\Program Files\DH Instruments\PPC4 Cockpit\Driver. Alternatively the driver can be updated from the General Accessories CD distributed with the PPC4. The proper directory will include the file “cyusb.inf”. [Browse] to locate the directory that contains the driver. Locate the appropriate directory. [Next >] to continue.

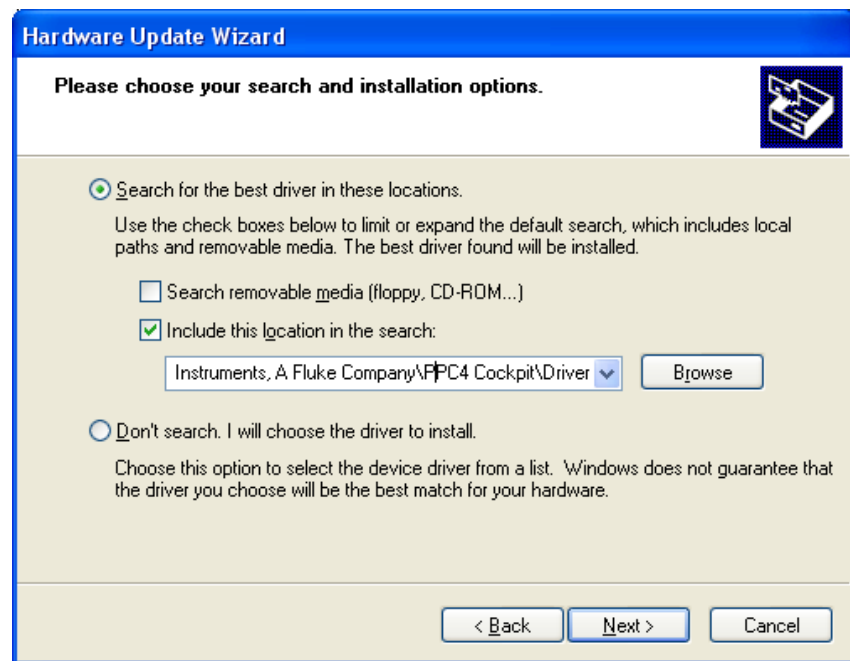

Figure 16. Driver Location

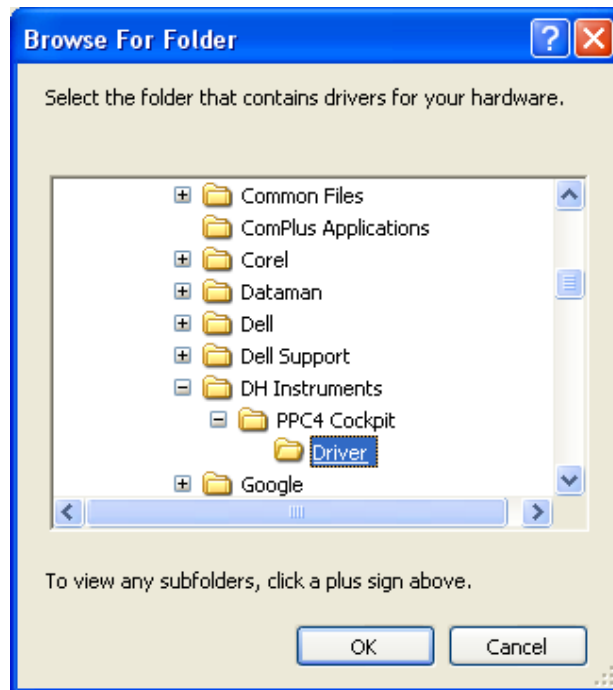

Figure 17. Browse for Driver Location

- 3 A driver warning message will display. The PPC4 USB driver has not been digitally signed for Windows Compatibility. **[Continue Anyway]** to proceed.



Figure 18. Driver Warning Message

- ④ The necessary files will be copied and the setup complete dialog will display. The PPC4 USB port can now be used with the PPC4 Cockpit. **[Finish]** to close the dialog.

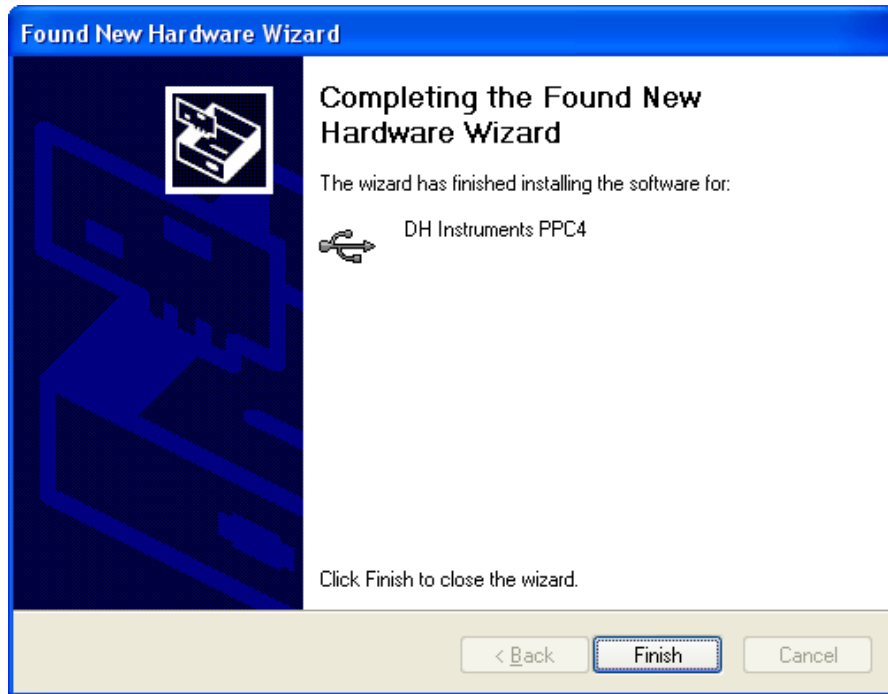

Figure 19. Driver Setup Complete

6.2.3 Running the Cockpit

The PPC4 Cockpit must be launched like any other application. It does not auto launch when the USB or RS232 ports are connected to the host PC. Use the desktop short-cut or the Windows Start menu to launch the PPC4 Cockpit. The opening program dialog provides the choice of interface to use for communication between the PPC4 and the PPC4 Cockpit. Select the appropriate interface to launch the Cockpit. The program loads the active PPC4 settings then displays the PPC4 Advanced display.

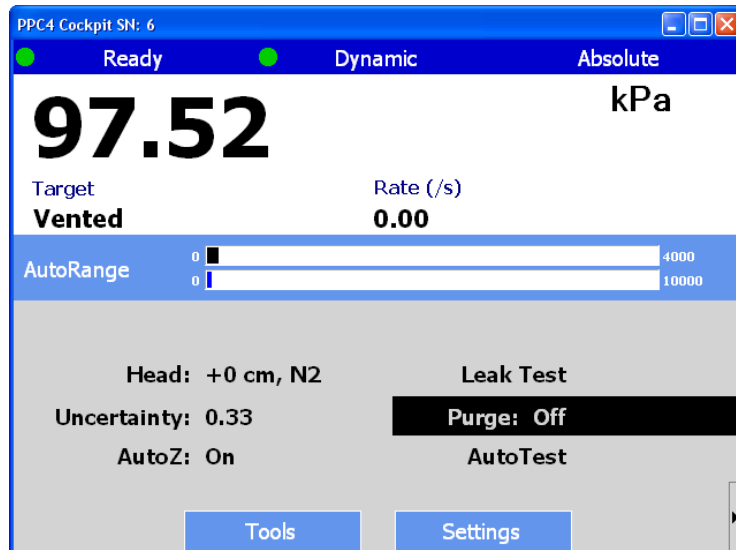

Figure 20. PPC4 Cockpit Main Display



Figure 21. PPC4 Cockpit Communication Selection

6.2.3.1 USB Interface

If USB is selected, a secondary dialog displays to facilitate the selection of the specific PPC4. Only PPC4s actively connected to the host PC via USB are listed. Choose the specific PPC4. **[OK]** to continue. The Cockpit will load the PPC4 information and run. There are no specific PPC4 menu options required to use the PPC4 via USB.

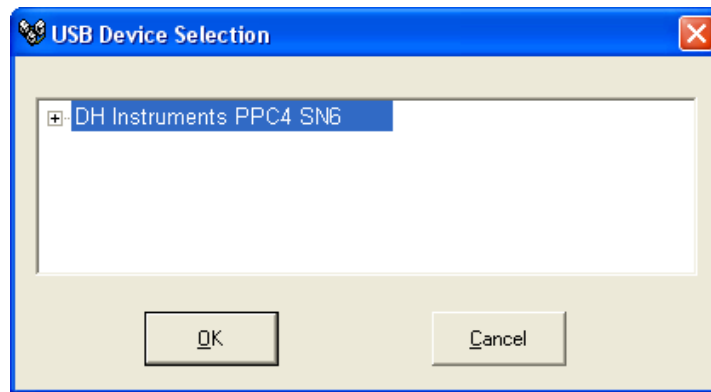

Figure 22. PPC4 Cockpit Communication Selection

6.2.3.2 RS232 Interface

Select **[RS232]** on the opening Cockpit dialog to communicate to the PPC4 via RS232. It is necessary to verify the PPC4 front panel RS232 settings prior to completing the RS232 setup in the PPC4 Cockpit. The selections on the RS232 Settings dialog represent the RS232 port that connects the host PC to the COM1 port of the PPC4. The RS232 settings must represent the RS232 settings obtained from the front panel of the PPC4 (see Sections 4.5.2.1 and 5.7.9.1).

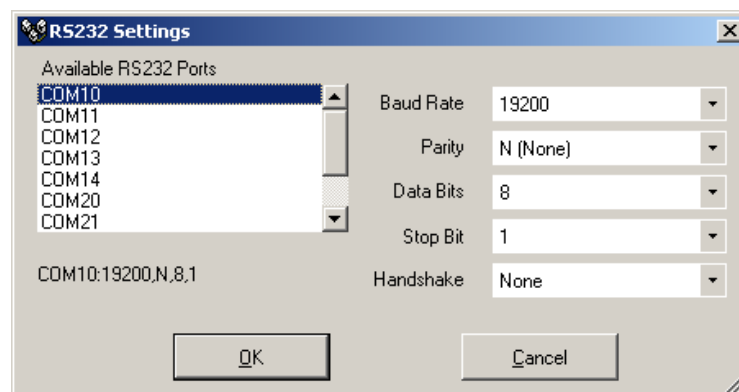

Figure 23. PPC4 Cockpit RS232 Settings

6.2.3.3 Keyboard Shortcuts

Several keyboard shortcuts are provided to emulate the pressure control buttons on the PPC4 front panel. See Table 18 for a list of all pressure control keyboard shortcuts. There is also a pressure control panel accessed by pressing the arrow on the bottom right of the PPC4 Cockpit display. The pressure control panel has the same function as the pressure control keys on the PPC4 front panel (see Section 3.2.1).

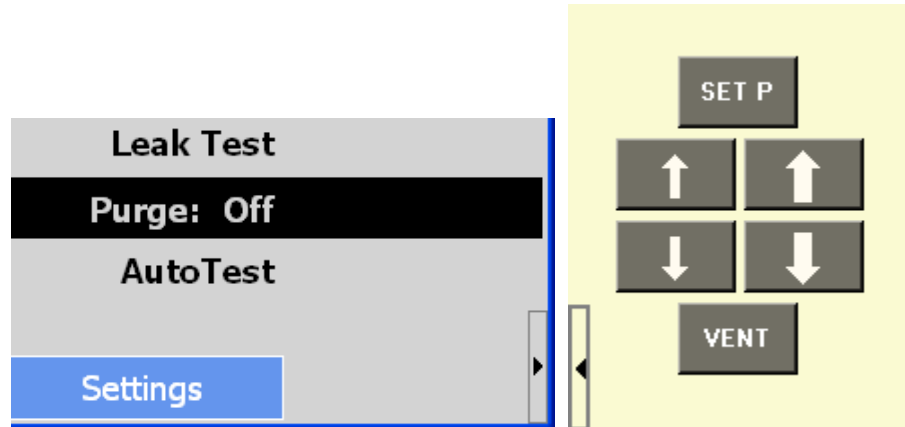

Figure 24. PPC4 Cockpit Pressure Control Buttons

Table 18. PPC4 Cockpit Keyboard Shortcuts

PC KEYBOARD SHORTCUT	PPC4 KEY	OPERATION
		Increase pressure at the fast slew rate. See Section 3.2.1.
		Decrease pressure using the fast slew rate. See Section 3.2.1.
		Increase pressure using the slow slew rate. When a dynamic control pressure target is active, the function changes to increase the target pressure by the jog step. See Section 3.2.1.
		Decrease pressure using the down slow valve. When a dynamic control pressure target is active, the function changes to decrease the target pressure by the jog step. See Section 3.2.1.
		Set a new target pressure. See Section 3.2.12.
		Toggle the state of the PPC4 vent valve. See Section 3.2.14.

6.3 Remote Interfacing

Sending a program message to the PPC4 places it into **Remote** mode. The remote indicator below the the display window lights when the PPC4 is in **Remote** mode. It will also flicker when a program message is received. The menus usually accessed from the front panel are locked out while in remote. **[ESC]** returns the PPC4 to local operation unless the **<REMOTE>** command, which locks out all keypad operation, was sent to the unit.

6.3.1 RS232 Interface

6.3.1.1 COM1

The PPC4 COM1 RS232 interface is located on the back of the unit. It is a 9-pin male DB-9F connector configured as a DCE device. Data is transmitted out of the unit using pin 2, and is received on pin 3. This allows a normal pin-to-pin DB-9M to DB-9F RS232 cable to be used to connect to a DTE host.

Caution

Handshaking is not required or supported. The COM1 receive buffer is 255 bytes deep. If the buffer overflows from sending too much data, the data will be lost. Because of this, it is essential to send a single program message at a time and it is essential to wait for the PPC4 to reply to a command before sending any other command.

Table 19. COM1 Pin Designations and Connections

PPC4 COM1 DB-9F PIN DESIGNATIONS			
PIN #	FUNCTION	DESCRIPTION	
2	TxD	This pin transmits serial data from the PPC4 to the host.	
3	RxD	This pin accepts serial data from the host computer.	
5	Grn	This pin is the common return for the TxD and RxD signals.	

IBM PC/XT DB-9F CONNECTIONS		IBM PC/XT DB-9M TO PPC4 DB9F CONNECTION	
DB-25M	DB-9F	DB-9M	DB-9F
2	3	3	3
3	2	2	2
7	5	5	5

6.3.1.2 COM2

The PPC4 COM2 RS232 interface is located on the back of the unit. Its most common use is to connect to **DHI** RPM4 reference pressure monitors to PPC4 to add external measurement devices to the PPC4 system (see Section 2.3.6)

COM2 can be used to allow the host computer to communicate with another device through the PPC4. This allows the user to use one host COM port to communicate with the PPC4 and an additional RS232 device. Refer to the **"#"** and **"PASSTHRU"** remote program commands for details.

COM2 is a 9-pin female DB-9F connector configured as a DTE device. Data is transmitted out of the unit using pin 3, and is received on pin 2. This allows a normal pin-to-pin DB-9M to DB-9F RS232 cable to be used to connect to a DCE device.

Handshaking is not required or supported.

Table 20. COM2 DB-9F Pin Designations

PIN #	FUNCTION	DESCRIPTION
2	RxD	This pin transmits serial data from the PPC4 to a device.
3	TxD	This pin accepts serial data from the external device.
4	DTR	This pin is Data Terminal Ready (DTR) (held at + 5 V).
5	Grn	This pin is the common return for the TxD and RxD signals.

6.3.1.3 RS232 Command Testing

An easy way to test RS232 communications independent of custom software is to use the Windows Hyperterminal found in the accessories group under All Programs (See Figure 25)

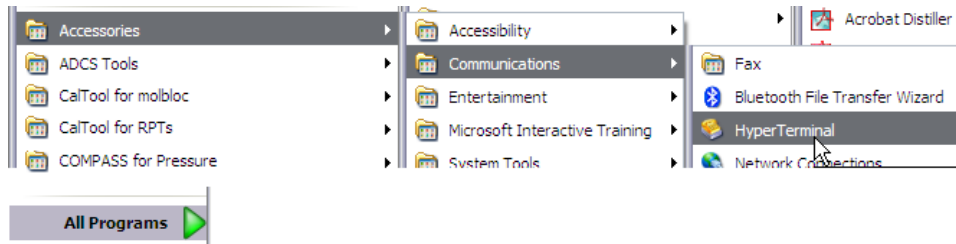

Figure 25. Windows selection of Hyperterminal

Hyperterminal must be configured to communicate with the PPC4 using the RS232 COM1 communication settings accessed through the PPC4 front panel (see Section 5.7.9.1 for the Advanced Interface and Section 4.5.2.1 for the Basic Interface). Refer to the following series of steps to configure Hyperterminal assuming that the PPC4 is connected to COM4 of a host PC using a baud rate of 2400, 7 data bits, event parity and 1 stop bit.

- 1 Figure 26 is displayed when Hyperterminal is run for the first time. Enter an easily identifiable name to reference the communications session. Future Hyperterminal sessions are initiated by selecting the named session.

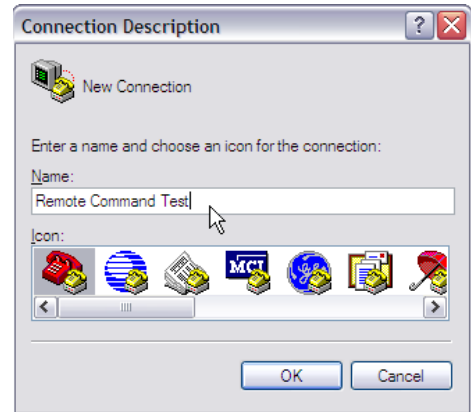
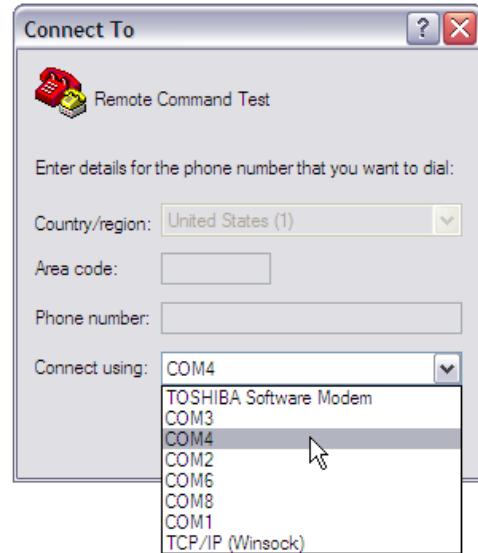
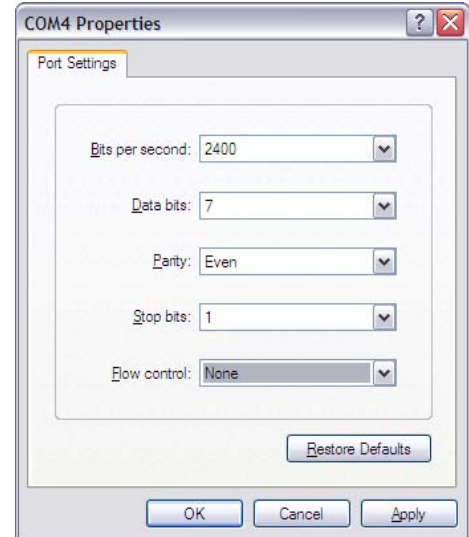

Figure 26. Hyperterminal Initial Display

- ② The next dialog defines the RS232 port to use for communication. Select the host PC's COM port that will be connected to the PPC4. Do not confuse this selection with the COM1 and COM2 ports on the back of the PPC4.



- ③ After the COM port selection, the RS232 settings of the PPC4 must be defined. The specific PPC4 settings are accessed through the PPC4 front panel. RS232 handshaking is not supported by the PPC4, therefore None is the appropriate selection for Flow Control.



- ④ The focus will return to the main Hyperterminal program after the COM port properties are defined. At this point, the last steps are to define command and response terminators. Access the [File] menu and select [Properties]

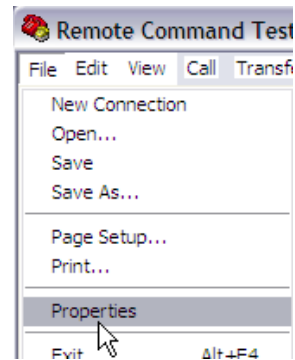

- 5 Within the Properties dialog, press the ASCII setup button.

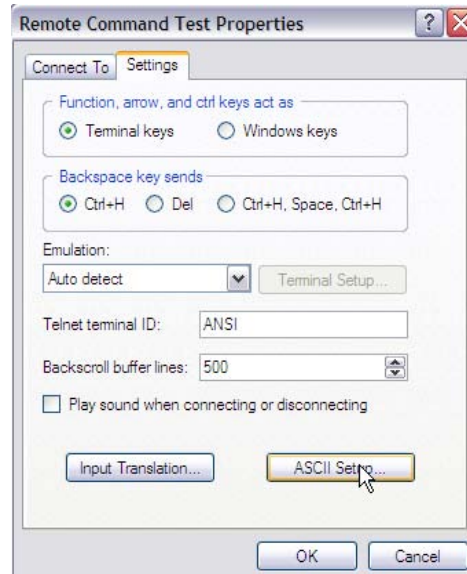

- 6 Make the selections listed in the figure below. These selections enable a carriage return (ASCII 13) and line feed (ASCII 10) to be appended to the end of the commands to the PPC4 and the corresponding responses. Press [OK] after the edits are complete.

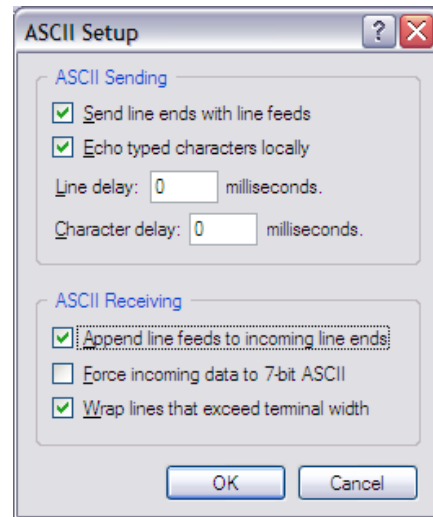
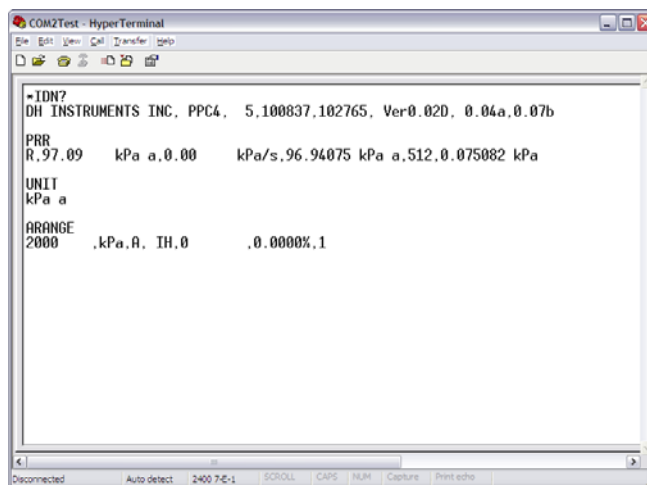

Figure 27. Hyperterminal ASCII Setup

- 7 At this point it is best to save and close the current Hyperterminal session. Open Hyperterminal a second time, choose [Cancel] on the opening dialog, then use the [File][Open] menu to select the file just created "Remote Command testing".



6.3.2 IEEE-488

The PPC4 IEEE-488 interface is located on the back of the unit. The physical and electrical interface conforms to IEEE Std 488.1-1987 Subset E2 and IEEE Std. 488.2-1992. Do not attempt to communicate with the IEEE-488 interface while using the COM1, Ethernet or USB interfaces. The IEEE-488 receive buffer is 250 bytes deep. If the buffer overflows, the PPC4 will hold off release of the NRFD handshake line until it can service and empty the receive buffer. This keeps the buffer from overflowing. It is recommended that you use the query form for all remote commands and wait for a reply to each command to ensure proper operation and order of command execution. Not reading a command response will cause the PPC4 to respond improperly to future remote commands.

6.3.2.1 IEEE-488 Remote Command testing

Verify IEEE-488 communication with the PPC4 by using a communication tool provided by the PC's IEEE-488 interface manufacturer. The following sequence describes the steps to setup and communicate with the PPC4 by using a NI (National Instruments) IEEE-488 adapter. Different versions of the NI adapter and cards from other manufacturers will have slightly different steps and labeling.

- ❶ Install the IEEE-488 interface into the host PC and verify that the adapter is properly setup.
- ❷ Connect the PPC4 to the host PC by using an IEEE-488 communications cable.
- ❸ Launch the NI Measurement and Automation Explorer. Locate the option to scan for instruments. The PPC4 should be detected at the addressed defined in [Settings],<Interface>,IEEE-488.

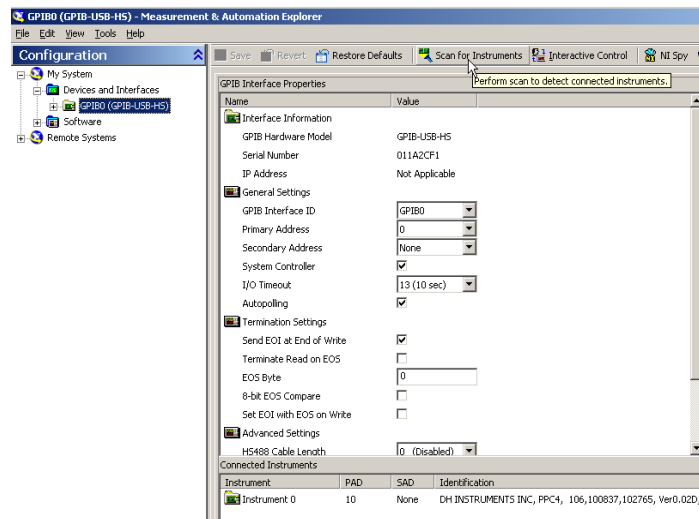

- ❹ Select the Communicate with Instrument option to invoke a dialog to enter discrete commands to the PPC4. No other specific PPC4 IEEE-488 setup is required.

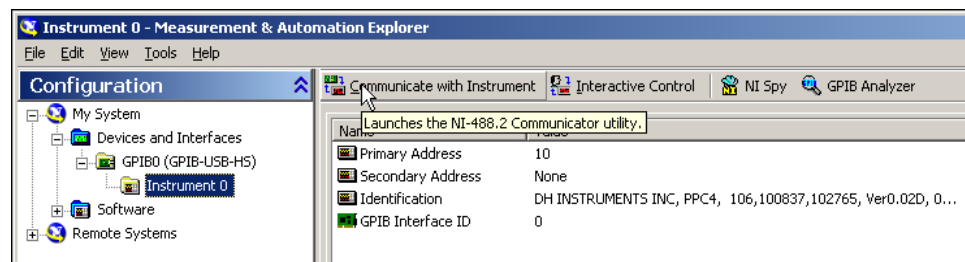

- 5 Enter a PPC4 command into the Send String field and choose [Query] or [Write] based on the command entered and the PPC4 command format. While communicating in Enhanced mode with IEEE-488, no response is provided by the PPC4 unless a “?” is included with the command. Attempting to read a response when a “?” is not included will yield an interface error. If a “?” is included and a response is not read, future commands will not respond properly. For this reason, make sure to use the [Read] button if [Write] was used to send a query form command

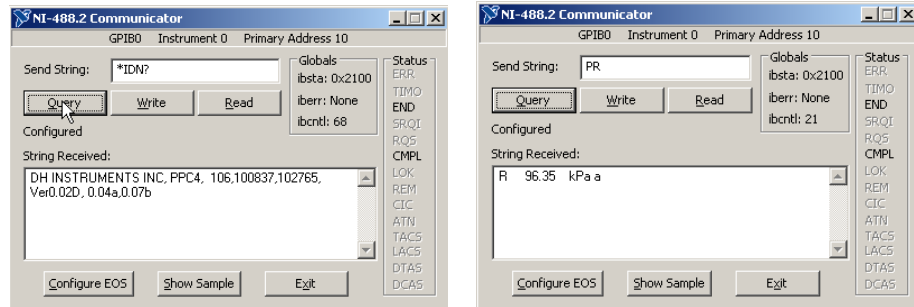

6.3.3 USB

The PPC4 can be connected to a PC via USB (Universal Serial Bus) through the port on the front of the instrument. If the PPC4 is equipped with the optional Ethernet module (see 6.3.4), the connection can be established via the secondary USB port on the back of the unit. Do not connect to both USB ports simultaneously. To connect the PPC4 to the PC use a standard USB device cable (included with the hardware). Connect the USB-B plug into the PPC4 USB socket and the USB-A plug to an available PC USB jack. It is not recommended to operate a PPC4 via legacy USB 1.x ports. Expansion cards are available to upgrade older PCs to USB 2.0. It is also not recommended to utilize USB extension cords. USB communication is supported only through PPC4 Cockpit and the PPC4 API (Application Programming Interface). Refer to the PPC4 API documentation on how to access the PPC4 programatically. To test USB communications run PPC4 Cockpit or use commercially available 3rd party tools.

Note

PPC4 API documentation is available at www.dhstruments.com in the software section as well as on the local PC as part of the PPC Cockpit installation at c:\DH\help\ppc4api.chm.

6.3.4 Ethernet (Optional)

The optional PPC4 Ethernet interface (8P8C modular connector socket) is located on the rear panel, paired with a secondary USB connector. Connect the PPC4 to a network switch via a standard CAT5 or CAT6 network (patch) cable. The PPC4 communicates with the PC via the Ethernet module using UDP/IP (User Datagram Protocol/Internet Protocol) on port 2362 (fixed). The IP address of the PPC4 can be assigned statically (typed in) or dynamically via DHCP (Dynamic Host Configuration Protocol) on your LAN (Local Area Network). It might be necessary to acquire special permission from your IT department in order to use static IP addresses on a corporate network. It is possible to directly connect the PPC4 to a PC using a network (patch) cable, bypassing a network. For direct connect enter static IP addresses on both the PPC4 LAN setup screen and the PC network adapter (refer to Windows documentation). To test communications via UDP use commercially available 3rd party tools.

6.4 Programming Formats

PPC4 supports two program message formats, “Classic” and “Enhanced”. The user must select which format to use. Selection can be accomplished from the front panel (see Section 5.7.9.2 for Advanced Interface and Section 4.5.2.3 for Basic Interface) or remotely using the “**MSGFMT**” program message (see Section 6.5.4).

The main difference between the two formats is that when using the IEEE-488 interface, a “?” must be included in an enhanced command for there to be a response from the PPC4. In all other cases (classic or enhanced), every command has a response. In addition, the enhanced message format supports IEEE Std. 488.2 syntax, format and status reporting.

The default is the classic format to allow downward compatibility with existing host software.

In either format, it is recommended that you start out a command sequence with the “***CLS**” command, which clears all of the communication and error queues. The basic commands are similar for both the classic and enhanced formats, but the usage, syntax, format and status reporting are different.

Note

The PPC4 program message set is downward compatible with the previous PPC3 program message set. In some cases additional arguments are available at the end of PPC4 commands that are not available in PPC3 commands. However the command function is not altered.

6.4.1 Classic Program Message Format

Each program message sent is also a query. Only one program message can be sent to the PPC4 at time. After sending any program message, the PPC4 must reply before another program message can be sent. The reply will contain data, or a numeric error message if the program message was invalid. The reply must be received before issuing another program message to the PPC4. This insures that the PPC4 has completed the program message. Most remote program messages will return a reply within 500 ms except:

“**PR**”, “**PRR**”, “**SR**”, “**ATM**”, “**RATE**”: Up to 2.0 seconds to allow a new measurement.

“**RPT**”, “**ARANGE**”: Up to 10 seconds

The syntax and format used for each program message in the classic mode is listed next to the keyword ‘Classic:’ in each program message summary in Section 6.5.4.

6.4.2 Enhanced Program Message Format

The enhanced program message format uses the IEEE Std. 488.2 format, syntax and status reporting. Errors are reported using the IEEE Std. 488.2 status reporting model. If an error is reported, the error is put into an Error Queue and the “**ERR?**” query program message can be used to get a text description of the most recent error. If you are using the IEEE-488 port, the service request line can be setup to be asserted if this occurs (see Section 6.6.2). In the enhanced format, there are two possible program message types for every program message. Each of these two types starts with the same basic text referred to as the program message header. The two types are COMMAND type and QUERY type commands.

6.4.2.1 Using Command Type Commands

Note

Enhanced format commands **DO NOT** reply when using the IEEE-488 interface unless a “?” is included in the command. There will be no response from PPC4 to non-query (no “?”) commands. Remote software can time-out waiting for a response from PPC4. However, in RS232 communications, there is always a response and the response **MUST** be read prior to issuing another command.

The COMMAND type of program message executes a process and can additionally send data to the PPC4 in the form of comma delimited arguments. This data is usually a setting of some sort that is stored in the PPC4. If data is specified, it must be preceded by at least one white space from the program message header and be within the range and format described in the program message description. The keyword “**Command:**” appears to the left of the required syntax in each program message description in Section 6.5.4 .

If you are using the IEEE-488 port, the Command type does not generate a reply unless you place a query operator “?” immediately after the command. You also may send multiple program messages at once by separating each program message with a semicolon. The commands are queued and executed in as received order after the entire message stream has been received, so care in determining order of execution is needed.

If you are using the RS232 port COM1, the Command type will always generate a reply so you **must** wait for a reply before issuing another program message. Because of this, you can only send one Command program message at a time while using the COM1 port.

Examples:

- **IEEE-488 enhanced mode command series using query operator:**

- “*CLS?” (Clear the error queue. Wait for reply.)
- “UNIT? KPA” (Generates a reply. User must wait for reply before continuing.)
- “MMODE? A” (Generates a reply. User must wait for reply before continuing.)
- “PS? 100” (Generates a reply. User must wait for reply before continuing.)

- **IEEE-488 enhanced mode commands without query operator:**

- “*CLS” (Clear the error queue. No reply.)
- “UNIT KPA” (No reply)
- “MMODE A” (No reply)
- “PS 100” (No reply)
- “ERR?” (Wait for reply. User should use “ERR?” query following a series of non query commands to check for errors that may have occurred.)

- **IEEE-488 enhanced mode multiple commands without query operator:**

- “*CLS” (Clear the error queue. No reply)
- “UNIT KPA;MMODE A;PS 100” (Three commands at once. No reply)
- “ERR?” (Wait for reply. User should use “ERR?” query following a series of non query commands to check for errors that may have occurred)

- **COM1 enhanced mode command:**

“*CLS” or “*CLS?”	(Clear the error queue. Wait for reply.)
“UNIT KPA” or “UNIT? KPA”	(Generates a reply. User must wait for reply before continuing.)
“MMODE A” or “MMODE? A”	(Generates a reply. User must wait for reply before continuing.)
“PS 100” or “PS? 100”	(Generates a reply. User must wait for reply before continuing.)

6.4.2.2 Using Query Type Commands

The QUERY type of program message just requests data from the PPC4. Placing the query operator “?” immediately after the command creates a query. Software **must** wait for a reply with a query. If any type of program message is sent to the PPC4 after a query before receiving a reply, the program message will be discarded and an error will be generated. Errors are reporting using the IEEE Std. 488.2 status reporting model. A Query program message always ends with a question mark. Most queries will return a reply within 200 ms except:

“PR?”, “PRR?”, “SR?”, “ATM?”, “RATE?”: Up to 2.0 seconds.

“RPT”, “ARANGE”: Up to 10 seconds

The syntax for using a QUERY program message is listed next to the keyword “Query:” in each program message summary in Section 6.5.4 .

6.5 Commands

6.5.1 Programming Messages

Table 21. Program Message List

#	Send a command string out of the PPC4 COM2 port.
ABORT	Stop pressure generation.
ARANGE	Read or set a new AutoRange to use.
ATM	Read the current atmospheric pressure (on-board barometer).
AUTOPURGE	Read or set the status of the automatic purge function.
AUTOVAC	Read or set the status of the control reference (EXHAUST port).
AUTOZERO	Read or set the status of the AutoZ automatic zeroing function.
CALAMB	Read or set the on-board barometer calibration
CMDTERP	Gets or sets the command interpretation header.
COM1	Read or set the configuration of the COM1 port.
COM2	Read or set the configuration of the COM2 port.
DATE	Read or set the current date.
DF	Decrease the pressure quickly (fast).
DISPUNC	Enable or disable display of uncertainty and select the display mode
DP	Decrease the pressure a given amount.
DRV	Read or set the status of the external valve drivers.
DS	Decrease pressure slowly.
ERR	Read the last error message.
GPIB	Read or set the GPIB interface address.
HEAD	Read or set the fluid head settings.
HS	Read or set the current control hold limit in pressure.
HS%	Read or set the current control hold limit in percent span of the active range.
ID	Read or set the PPC4 alphanumeric asset ID tag.

IF	Increase the pressure quickly (fast).
IP	Slowly increase the pressure a given amount.
IS	Increase the pressure slowly.
Ln	Gets or sets the command interpreter mode.
LAN	Read or set the optional network interface settings.
LL	Read or set the lower limit for the current range (negative gauge mode only).
LOCAL	Return control to the PPC4 front panel.
MEM	Read the power-up memory test status.
MMODE	Read or change the active measurement mode.
MODE	Read or set the current pressure control mode.
MSGFMT	Read or set the type of program message format to use.
NVENT	Read or set the status of the lo vent valve (Gxxx or BGxxx Q-RPT only).
PASSTHRU	Send a command string out of the PPC4 COM2 port.
PCAL:IH	Read or set the user Hi RPT calibration information.
PCAL:IL	Read or set the user Lo RPT calibration information.
PCALUNC:IH PCALUNC:IL	Read or set the Q-RPT uncertainty settings used to determine the RPT's measurement uncertainty during operation.
PR	Read the next PPC4 pressure.
PRR	Read the next available pressure, rate, on-board barometer reading, control status, and the QRPT uncertainty.
PS	Set a new target pressure and start automated pressure control.
PSF	Set a new target pressure and use only the fast speed to reach the target.
PSS	Set a new target pressure and use only the slow speed to reach the target.
QPRR	Quickly read the last known pressure, rate, on-board barometer reading, control status and QRPT uncertainty.
RANGE	Read or set and Q-RPT or utility sensor default range (PPC4 command).
RATE	Read the next available rate of change of pressure.
READYCK	Read or set a flag that is cleared by a <i>Not Ready</i> condition.
REMOTE	Enable remote local lockout operation.
RES	Read or set the pressure display resolution for the current transducer and range.
RESET	Reset the PPC4 to the default user parameters.
RETURN	Start a new automated pressure control set using the current target value.
RPT	Read the available Q-RPT data or initiate the RPT search process.
SCRSAV	Read or set the front panel display screen saver activation time & type.
SN	Read the serial number of the PPC4.
SR	Read the next available pressure status (<i>Ready/Not Ready</i>).
SS	Read or set the stability required for a <i>Ready</i> condition.
SS%	Read or set the stability required for a <i>Ready</i> condition (% span/ s).
STAT	Read the pressure control status.
TIME	Read or set the current time of day.
TIMEFMT	Read or set the clock time format.
TP	Read the current target pressure.
UCOEF	Convert a pressure in Pascal to pressure in the current units.
UDU	Read or set the user defined pressure unit.
UL	Read or set the upper limit for the current range.
UNIT	Read or set the pressure unit of measure for the current range.
VAC	Read or set the exhaust reference status flag.
VENT	Read, execute or abort a vent process.
VER	Read the PPC4 software version.
ZOFFSETn	Read or set the AutoZero P_{offset} for the specified Q-RPT.
ZOFFSET:IH	Read or set the AutoZ offset for Hi RPT.
ZOFFSET:IL	Read or set the AutoZ offset for Lo RPT.

6.5.2 Error Messages

Table 22. Error #s and Descriptions

REPLY	DESCRIPTION
ERR# 0	"OK"
ERR# 2	"Text argument is too long"
ERR# 3	"Arguments cannot be 0"
ERR# 4	"External device not detected"
ERR# 5	"External device improperly configured"
ERR# 6	"Numeric argument missing or out of range"
ERR# 7	"Missing or improper command argument(s)"
ERR# 8	"External device time-out error"
ERR# 9	"Unknown command"
ERR# 10	"Missing or invalid command suffix"
ERR# 11	"Command missing argument"
ERR# 12	"System overpressured" or "overpressure may result"
ERR# 13	"Text queue overflow"
ERR# 14	"User unit not defined"
ERR# 16	"Generation failure"
ERR# 18	"Command not yet available"
ERR# 19	"Not available with absolute units"
ERR# 20	"Not available with gauge device"
ERR# 21	"User device not defined"
ERR# 22	"Pressure is not stable"
ERR# 23	"Option not available or installed"
ERR# 24	"Unit must be vented"
ERR# 25	"Transducer out of calibration"
ERR# 26	"COM port failed to initialize"
ERR# 27	"Internal device failure"
ERR# 28	"Device failure"
ERR# 29	"Device not available"
ERR# 30	"Must be on range IH"
ERR# 31	"Exceeds upper or lower limit"
ERR# 32	"Not stable enough"
ERR# 37	"Data table is full"
ERR# 38	"Selected range is not available"
ERR# 39	"Data verify error"
ERR# 45	"Argument not allowed"
ERR #46	"Argument cannot be negative"
ERR #52	"Command obsolete"
ERR# 53	"Not Available"

6.5.3 Program Message Description Overview

Each program message description is separated into the following sections:

Purpose	A brief description of the programs message's function.
Command	This is the Enhanced program message syntax to send data to the PPC4 or to execute a PPC4 function. The PPC4 must be set to use the enhanced format (see Section 3.5.2.3) to use the syntax and style shown. It may be sent alone, or followed by at least one white space and additional argument(s) to show that arguments can be passed. If there are multiple arguments, then commas must separate them. If you are using the IEEE-488 port, multiple command type program messages can be sent in one message if you separate them with a semicolon. There will be no reply from the PPC4 using the IEEE-488 port unless the command is immediately followed by the query operator "?". If you are using the COM1 port, the PPC1 will reply and you must wait for this reply. If this field is not listed in the program message description, then the Command type is not supported when using the Enhanced format.
Query	This is the Enhanced program message syntax to request data from the PPC4. The PPC4 must be set to use the enhanced format (see Section 3.5.2.3). The PPC4 will always reply to a query. You must wait for this reply before issuing another program message. If this field (Query) is not listed in the program message description, then the Query type for the program message is not supported when using the Enhanced format.
Classic	This is the Classic program message syntax to send data to the PPC4, to execute a PPC4 function, or to query for data. The PPC4 must be set to use the classic format (see Section 3.5.2.3). The command may be followed by a '(=)' and additional argument characters to show that argument(s) can be passed. If there are multiple arguments, then commas must separate them. The PPC4 will always reply to a Classic program message. You must wait for this reply before issuing another program message. If this field is not listed in the program message description, then it is not supported when using the classic format.
Arguments	If the program message can be used to set data inside the PPC4, then this section describes the arguments and their limits.
Default	If the program message can be used to set data inside the PPC4, then this line shows (using the enhanced format) the default setting from the factory.
Remarks	This field has the details and remarks about the command.
Example	Examples are given for the enhanced and classic methods. Enhanced: An example of the use of an enhanced format program message to be sent to the PPC4 is shown. The message sent to the PPC4 appears after the "Cmd sent:" label. If only a Query type exists, the "Query sent:" label is shown instead. Directly under this label, "Query reply" shows a typical reply to a query type. "Reply:" shows that a query format does not exist. It may have a short description next to it. Classic: An example of the use of a classic program message to be sent to the PPC4 is shown. The command sent to the PPC4 appears after the "Cmd sent:" label. The "Reply" label shows a typical reply to the "Sent" example. It may have a short description next to it.
Errors	If the program message can report an argument error, the types of errors are listed. If using the classic format or the COM1 port, the error message is replied after receiving the program message. If using the enhanced format via the IEEE-488 port, the error condition is handled by the status reporting model which stores the errors in an Error Queue and can be programmed to assert the IEEE-488 SRQ line to signal an error has occurred. In either case, the "ERR" or "ERR?" program message can be used to retrieve a text description of the error.
See Also	Indicates related command ("----") and refers to manual sections giving detail on PPC4 operation corresponding to the program message.

6.5.4 Program Message Descriptions

#	
Purpose	To allow the host PC to communicate with a device connected to the PPC4 COM2 port. The preferred method is to use the "PASSTHRU" program message.
Classic	"#xx"
Arguments	xx: The string to send out of the COM2 port. It must be less than 40 characters long.
Remarks	<p>The PPC4 COM2 port can be used to communicate to another RS232 device (such as another PPC4). This allows the user to use one COM port or IEEE-488 port on the host computer to communicate with the PPC4 and another device. A carriage return and a line feed (<CR><LF>) are added to the string.</p> <p>After this program message is issued, the PPC4 will reply back the first string received by the PPC4 COM2 port that is terminated with a carriage return. Line feeds are discarded.</p> <p>This will discontinue when the next program message is sent to the PPC4.</p> <p>There is no other reply from this program message. Prior to using this program message, you must ensure that the PPC4 COM2 port is correctly set up to communicate with the device on COM2. Refer to the "COM2=" program message.</p>
Example (classic)	<p>Sent: "#VER"</p> <p>Reply: "DH INSTRUMENTS, INC PPC4 us A1000/A0015 Ver2.00 "</p> <p>This example assumes that a second PPC4's COM1 port is connected to the PPC4 COM2 port. This example gets the version of the second PPC4.</p>
See Also	<p>"PASSTHRU", "COM2"</p> <p>3.2.24</p> <p style="text-align: center;">Note</p> <p>COM2 is generally used for connecting DHI RPM4s to supply external measurement devices in which case communications are handled automatically by the PPC4.</p>

ABORT

Purpose	Stops active pressure generation/control. All control valves are closed. The exhaust and transducer isolation valves are not affected.
Command Classic	"ABORT"
Remarks	This program message has no effect if the PPC4 is not using automated pressure control. When using automated pressure control, it aborts the control. This command is recommended to idle the PPC4 before setting a new target pressure.
Example (enhanced)	<p>Cmd sent: "ABORT"</p> <p>Reply: "ABORT" (no reply if IEEE-488)</p>
Example (enhanced)	<p>Cmd sent: "ABORT?"</p> <p>Reply: "ABORT"</p>
Example (classic)	<p>Sent: "ABORT"</p> <p>Reply: "ABORT"</p>
See Also	3.2.12, 3.2.2

ARANGE	
Purpose	Read existing AutoRange range or create a new AutoRange range.
Command Query	"ARANGE <i>Range, unit, mode</i> (<i>,RptLabel</i>)" "ARANGE?"
Classic	"ARANGE= <i> Range, units, mode</i> (<i>,RptLabel</i>)" "ARANGE"
Arguments	<p><i>Range</i> The AutoRange maximum pressure. Cannot be negative.</p> <p><i>Unit:</i> The unit of measure of the <i>Range</i> argument.</p> <p><i>Mode:</i> The measurement mode of the <i>Range</i> argument: "A" for absolute "G" for gauge "N" for negative gauge</p> <p style="text-align: center;">Note Measured pressure values are returned with "g" to identify measurement mode for both gauge and negative gauge measurement modes.</p> <p><i>RptLabel:</i> One of the Internal or External RPTs that is available. (optional) "IH": Internal, Hi Q-RPT "IL": Internal, Lo Q-RPT "X1H": External RPM4, Hi Q-RPT "X1L": External RPM4, Lo Q-RPT</p>
Remarks	<p>The ARANGE command is used to define a PPC4 range by specifying a desired unit of measure, measurement mode and maximum pressure, and have the PPC4 pick the best available Q-RPT and make operational adjustments to optimize that range. Available Q-RPTs may be determined by the use of the "RPT" command to search for external RPM4 devices or use of the [RPT] function key.</p> <p>The optional "<i>RptLabel</i>" argument can be used to specify which Q-RPT you wish to use for the AutoRange range instead of allowing the PPC4 to pick the best Q-RPT. By using this option you can override the internal logic that picks the most suitable Q-RPT. This Q-RPT must have been previously found using the "RPT" command, [RPT Search] or <RPT> and must be valid for the maximum pressure and measurement mode specified.</p> <p>The reply indicates the current range data, including the <i>RptLabel</i> used for the range.</p> <p>If a water column unit (inH2O, mH2O, mmH2O) is specified for the pressure unit of measure, the temperature reference can be given after the unit text. For example, "inH2O4", "inH2O20" or "inH2O60" corresponds to inH2O at 4 °C, 20 °C or 60 °F. If no temperature is specified, a default of 20 °C is assumed. There is no indication of the temperature reference in the reply.</p>
Example (enhanced)	<p>Cmd sent: "ARANGE?" (read the current range in the current units)</p> <p>Query reply: "100.00, psi, A, IH"</p>
Example (classic)	<p>Cmd sent: "ARANGE" (read the current range in the current units)</p> <p>Query reply: "100.00, psi, A, IH"</p>
Example (enhanced)	<p>Cmd sent: "ARANGE? 250, inWa4, G (range of 250 inWa @ 4 °C in gauge mode)</p> <p>Query reply: "250.000 inWa, G, X2H" (Hi RPT of 2nd external RPM4 used)</p>
Example (classic)	<p>Cmd sent: "ARANGE=250, kPa, G (set a range of 250 kPa in gauge mode)</p> <p>Query reply: "250.00 kPa, G, X1L" (Lo RPT of 1st external RPM4 used)</p>
Example (enhanced)	<p>Cmd sent: "ARANGE 50, psi, A, X1L (set a range of 50 psi in absolute mode on Lo RPT of 1st RPM4)</p> <p>Query reply: "50.000 psi, A, X1L" (No reply if IEEE-488)</p>
Errors	<p>ERR# 4: RPT previously found not detected. Usually occurs when the external RPM4(s) have been disconnected since the last RPT "search"</p> <p>ERR# 5: RPT previously found not the same as now found. Usually occurs when the external RPM4(s) connections to the PPC4 have been changed since the last RPT "search".</p> <p>ERR# 6: "<i>Range</i>" maximum pressure exceeds available RPTs or is negative.</p> <p>ERR# 19: Cannot Range to '0' with absolute units.</p> <p>ERR# 20: Cannot Range to '0' with gauge units.</p> <p>ERR# 29: Correct type of RPT for the selected "<i>Mode</i>" is not available.</p>
See Also	"RPT", "RANGE" 3.2.8. 3.2.5, 3.2.6, 3.2.11

ATM	
Purpose	Reads the next measured pressure from PPC4's on-board barometer (if present).
Query	"ATM?"
Classic	"ATM"
Remarks	The atmospheric pressure as measured by the PPC4 on-board barometer is returned in the current pressure units (always absolute). This measurement is followed by the units text. Not all PPC4s are equipped with an on-board barometer.
Example (enhanced)	Query sent: "ATM?" Query reply: "97.12348 kPaa"
Example (classic)	Sent: "ATM" Reply: "97.12384 kPaa"
Errors	ERR# 23: PPC4 is not equipped with a barometer.
See Also	3.2.27.3

AUTOPURGE	
Purpose	Read or set the status of the automatic purge function.
Command	"AUTOPURGE n"
Query	"AUTOPURGE?"
Classic	"AUTOPURGE=n" "AUTOPURGE"
Default	"AUTOPURGE 0"
Arguments	n: '0' To disable AUTO mode. '1' To enable AUTO mode.
Remarks	The PPC4 can automatically control the external SPLT functions to purge the test system before running a test, if desired.
Example (enhanced)	Cmd sent: "AUTOPURGE 1" Query reply: "1" (No reply if IEEE-488)
Example (enhanced)	Cmd sent: "AUTOPURGE 1" Query reply: "1"
Example (classic)	Sent: "AUTOPURGE=1" Query reply: "AUTOPURGE=0"
Errors	ERR# 6: The argument was other than a '0' or a '1'.
See	3.2.17, 3.2.27.4

AUTOVAC	
Purpose	Read or set the status of the automated Control Ref determination mode.
Command	"AUTOVAC n"
Query	"AUTOVAC?"
Classic	"AUTOVAC=n" "AUTOVAC"
Default	"AUTOVAC 1"
Arguments	n: '0' To disable AUTO mode. ("VAC" cmd determines status) '1' To enable AUTO mode. This will override the manual selection.
Remarks	At low pressures, PPC4 control is affected by whether the EXHAUST port is open to atmosphere or connected to vacuum. The PPC4 has an internal sensor that can be used to automatically determine if the EXHAUST port is open to atmosphere or to a vacuum. You can disable it to manually override it. It is recommended to use the "VAC" command to disable this feature instead of the "AUTOVAC=0" command, as you can also specify vacuum or atmospheric reference at the same time with the VAC command.
Example (enhanced)	Cmd sent: "AUTOVAC 1" Query reply: "1" (No reply if IEEE-488)
Example (enhanced)	Cmd sent: "AUTOVAC 1" Query reply: "1"
Example (classic)	Sent: "AUTOVAC=0" Query reply: "AUTOVAC=0"
Errors	ERR# 6: The argument was other than a '0' or a '1'.
See Also	"VAC" 3.2.27.2

AUTOZERO	
Purpose	Read or set the status of the AutoZ function.
Command	"AUTOZERO <i>n</i> "
Query	"AUTOZERO?"
Classic	"AUTOZERO= <i>n</i> " "AUTOZERO"
Default	"AUTOZERO 1"
Arguments	<i>n</i> : '0' Autozero OFF '1' Autozero ON
Remarks	The PPC4 AutoZ function can be turned ON and OFF. There is a separate AutoZ flag for the gauge and absolute modes for each RPT. This command sets the AutoZ status for the current mode of the active internal or external RPT only.
Example (enhanced)	Cmd sent: "AUTOZERO 0" Query reply: "0" (No reply if IEEE-488)
Example (enhanced)	Cmd sent: "AUTOZERO? 0" Query reply: "0"
Example (classic)	Sent: "AUTOZERO=1" Query reply: "AUTOZERO=0"
Errors	ERR# 6: The argument was other than a '0' or a '1'.
See Also	"ZOFFSET", "MMODE" 3.2.22

CALAMB	
Purpose	Read or set the on-board barometer calibration coefficients.
Command	"CALAMB <i>adder, mult, CalDate</i> "
Query	"CALAMB?"
Classic	"CALAMB= <i>adder, mult, CalDate</i> " "CALAMB"
Defaults	"CALAMB = 0.0, 1.0, 19800101"
Arguments	<i>Adder</i> : The Barometer calibration adder (PA).In Pascal. <i>Mult</i> : The Barometer calibration multiplier (PM) from 0.1 to 100. <i>CalDate</i> : The date of the calibration in the format "YYYYMMDD"
Remarks	The barometer calibration information can be accessed with this program message. Using this program message overwrites the current calibration coefficients, so caution must be used. Changes made take effect immediately.
Example (enhanced)	Cmd sent: "CALAMB? 2.1, 1.000021, 20011201" Query reply: " 2.10, 1.000021, 20011201" (No reply if IEEE-488)
Example (classic)	Sent: "CALAMB=2.1, 1.000021, 20011201" Reply: " 2.1, 1.000021, 20011201"
Errors	ERR# 6: One of the arguments is out of range.
See Also	3.2.27.3, 7.3

COM1	
Purpose	Read or set the RS232 settings for the COM1 port.
Command	"COM1 <i>baud, parity, data, stop</i> "
Query	"COM1?"
Classic	"COM1= <i>baud, parity, data, stop</i> " "COM1"
Arguments	<i>Baud:</i> The baud rate. This may be '2400', '4800', '9600' or '19200'. <i>Parity:</i> The data parity. This may be 'O' for odd, 'E' for even, or 'N' for none. <i>Data:</i> The number of data bits. This may be '7' or '8'. <i>Stop:</i> The number of stop bits. This may be '1' or '2'.
Defaults	"COM1 2400,E,7,1"
Remarks	The COM1 port is used to communicate to the PPC4. When the COM1 port configuration of the PPC4 is changed, the program message reply (COM1 use only) is sent at the old COM1 settings, but all subsequent communications are accomplished at the new COM1 settings. A 200ms or longer delay after receiving the reply to this command will ensure that the PPC4 has changed the COM port settings and is ready for communications at the new settings.
Example (enhanced)	Cmd sent: "COM1 9600,N,8,1" Query reply: "9600,N,8,1" (No reply if IEEE-488)
Example (enhanced)	Cmd sent: "COM1? 9600,N,8,1" Query reply: "9600,N,8,1"
Example (classic)	Sent: "COM1=9600,N,8,1" Reply: "9600,N,8,1"
Errors	ERR# 7: Missing or improper program message argument(s).
See Also	"PASSTHRU" 3.2.24

COM2	
Purpose	Read or set the RS232 settings for the COM2 port.
Command	"COM2 <i>baud,parity,data,stop</i> "
Query	"COM2?"
Classic	"COM2= <i>baud,parity,data,stop</i> " "COM2"
Arguments	<i>baud:</i> The baud rate. This may be '2400', '4800', '9600' or '19200'. <i>parity:</i> The data parity. This may be 'O' for odd, 'E' for even, or 'N' for none. <i>Data:</i> The number of data bits. This may be '7' or '8'. <i>stop:</i> The number of stop bits. This may be '1' or '2'.
Defaults	"COM2 2400,E,7,1"
Remarks	COM2 is generally used to connect DHI RPM4 external measurement devices. The COM2 port can also be used to allow the host computer to communicate through the PPC4 to an additional device connected to COM2. This can be useful if the host computer does not have 2 serial ports available.
Example (enhanced)	Cmd sent: "COM2 9600,N,8,1" Query reply: "9600,N,8,1" (No reply if IEEE-488)
Example (enhanced)	Cmd sent: "COM2? 9600,N,8,1" Query reply: "9600,N,8,1"
Example (classic)	Sent: "COM2=9600,N,8,1" Reply: "9600,N,8,1"
Errors	ERR# 7: Missing or improper program message argument(s).
See Also	"#", "PASSTHRU" 3.2.24

DATE	
Purpose	Read or set the PPC4 date.
Command	"DATE <i>date</i> "
Query	"DATE?"
Classic	"DATE= <i>date</i> " "DATE"
Arguments	<i>date</i> : The date in the numerical only format YYYYMMDD.
Remarks	The PPC4 has an internal real time calendar clock. It is used for date stamping calibrations. The reply is always in the YYYYMMDD format.
Example (enhanced)	Cmd sent: "DATE 20030115" Query reply: "20030105" (No reply if IEEE-488)
Example (enhanced)	Cmd sent: "DATE? 20030105" Query reply: "20020105"
Errors	ERR# 7: Missing or improper program message argument(s).
See Also	"TIME" 3.2.26.3

DF	
Purpose	Decrease the pressure quickly (fast).
Command	"DF <i>n</i> "
Classic	"DF= <i>n</i> "
Arguments	'0' Closes the fast down valve. '1' Opens the fast down valve.
Remarks	Opening the fast down valve causes the pressure to decrease quickly.
Example (enhanced)	Cmd sent: "DF 1" Reply: "1" (no reply if IEEE-488)
Example (enhanced)	Cmd sent: "DF? 1" Reply: "1"
Example (classic)	Sent: "DF=1" Reply: "DF=1"
Errors	ERR# 6: The <i>n</i> argument is a '0' or a '1'.
See Also	"IF", "DS", "IS", "IP", "DP", Figure 31

DISPUNCn	
Purpose	Read or set the Q-RPT uncertainty display mode.
Command	"DISPUNC <i>n</i> <i>Enable, Mode</i> "
Query	"DISPUNC <i>n</i> ?"
Classic	"DISPUNC <i>n</i> = <i>Enable, Mode</i> " "DISPUNC <i>n</i> "
Defaults	"DISPUNC <i>n</i> = 1, 1"
Suffix	<i>n</i> : '1' to access the IH RPT settings '2' to access the IL RPT settings
Arguments	<i>Enable</i> : '0' or '1' to disable or enable the uncertainty display. <i>Mode</i> : '0' or '1' to display measured or delivered pressure uncertainty (optional).
Remarks	The <i>Mode</i> argument is optional, so that the display can be enabled or disabled without changing the mode.
Example (enhanced)	Cmd sent: "DISPUNC 1, 1" Query reply: "1, 1" (No reply if IEEE-488)
Example (classic)	Sent: "DISPUNC=0" Reply: "0, 1"
Errors	ERR# 6: One of the arguments is out of range.
See Also	"PCALUNC" command 3.2.29

DP	
Purpose	Decrease the pressure slowly a given amount using the slow speed.
Command	"DP <i>n</i> "
Classic	"DP= <i>n</i> "
Arguments	<i>n</i> : The decrease in pressure desired (current pressure units). This can be from 0 to 2 % FS of the active range.
Remarks	The slow speed will be used for a calculated amount of time (up to 5 seconds) to create the desired change. The PPC4 will not attempt to control the pressure to a target, so the change in pressure will be approximate. This is the equivalent of using  .
Example (enhanced)	Cmd sent: "DP 2" Reply: "2.000 kPa" (no reply if IEEE-488)
Example (enhanced)	Cmd sent: "DP? 2" Reply: "2.000 kPa"
Example (classic)	Sent: "DP=2" Reply: "2.000 kPa"
Errors	ERR# 6: The <i>n</i> argument is not within given limits.
See Also	"IP", "DS", "IS", "DF", "IF" 3.2.1

DRV<i>n</i>	
Purpose	Read or set the status of external electrical drivers.
Command	"DRV <i>n x</i> "
Query	"DRV <i>n?</i> "
Classic	"DRV <i>n=x</i> " "DRV <i>n</i> "
Arguments	<i>n</i> : The driver to operate. This can be from 1 to 8. <i>x</i> : The state to change the driver to; '0' to de-activate it, '1' to activate it.
Remarks	The PPC4 control has eight optional external drivers. Driver is used by the optional Purge function.
Example (enhanced)	Cmd sent: "DRV1 1" Query reply: "1" (No reply if IEEE-488)
Example (enhanced)	Cmd sent: "DRV2? 1" Query reply: "1"
Example (classic)	Sent: "DRV1=1" Reply: "DRV1=1"
Errors	ERR# 6: The <i>n</i> or <i>x</i> arguments are not within given limits.
See Also	3.2.23

DS	
Purpose	Decrease the pressure slowly.
Command	"DS <i>n</i> "
Classic	"DS= <i>n</i> "
Arguments	<i>n</i> : '0' Closes the slow down valve. '1' Opens the slow down valve.
Remarks	Opening the slow down valve causes the pressure to decrease slowly.
Example (Enhanced)	Cmd sent: "DS 1" Reply: "1" (no reply if IEEE-488)
Example (Enhanced)	Cmd sent: "DS? 1" Reply: "1"
Example (Classic)	Sent: "DS=1" Reply: "DS=1"
Errors	ERR# 6: The <i>n</i> argument is a '0' or a '1'.
See Also	"IS", "DF", "IF", "DP", "IP" Figure 31

ERR	
Purpose	Read the new available error message from the Error Queue.
Query	"ERR?"
Classic	"ERR"
Remarks	This program message obtains additional details about an error that has occurred. If the user receives an "ERR# nn" reply, or the enhanced mode is enabled using the IEEE-488 interface and an error has been detected, the error is put into a FIFO Error Queue. The "ERR" program message pulls and replies the oldest error message available. "OK" is replied if there are no error messages left.
Example (enhanced):	Query sent: "ERR?" Query reply: "Numeric argument missing or out of range"
Example (classic)	Sent: "ERR" Reply: "Numeric argument missing or out of range"
See Also	6.5.2

GPIB	
Purpose	Read or set the GPIB interface address.
Command	"GPIB addr"
Query	"GPIB?"
Classic	"GPIB=addr" "GPIB"
Defaults	"GPIB 10"
Arguments	addr: The address of the GPIB488 interface (1 to 31)
Remarks	The GPIB address is changed following the reply of this command. Each device on a GPIB interface bus requires a unique address.
Example (enhanced)	Cmd sent: "GPIB 21" Query reply: "21" (No reply if IEEE-488)
Example (enhanced)	Cmd sent: "GPIB? 21" Query reply: "21"
Example (classic)	Sent: "GPIB=21" Reply: "21"
Errors	ERR# 6: The argument is not within given limits.
See Also:	3.2.24

HEAD	
Purpose	Read or set the fluid head settings.
Command	"HEAD <i>h,u,f</i> "
Query	"HEAD?"
Classic	"HEAD= <i>h,u,f</i> " "HEAD"
Defaults	"HEAD 0,cm,N2"
Arguments	<i>h</i> : The height of the test in relation to the PPC4. This is positive if the test is above the PPC4, or negative if below the PPC4. This value can be between - 9999 and 9999. Setting this value to '0' disables the head correction. <i>u</i> : The height units. This must be "in" or "cm". <i>f</i> : The fluid type. This must be "N2", "Air", "He" or "User".
Remarks	The PPC4 can make a fluid head correction to allow it to display the pressure at the level of the device under test instead of at the level of the PPC4.
Example (enhanced)	Cmd sent: "HEAD 10,in,N2" Query reply: "10, in, N2"
Example (classic)	Sent: "HEAD=10,in,N2" Reply: "10, in, N2"
Errors	ERR# 6: The arguments are not within given limits.
See Also:	3.2.16

HS	
Purpose	Read or set the automated pressure control hold limit as a pressure value.
Command	"HS <i>hold</i> "
Query	"HS?"
Classic	"HS= <i>hold</i> " "HS"
Arguments	<i>Hold</i> : The hold limit in the current pressure unit of measure.
Remarks	The hold limit can be read and set as a pressure.
Example (enhanced)	Cmd sent: "HS .1" Query reply: "0.1 kPa" (No reply if IEEE-488)
Example (enhanced)	Cmd sent: "HS? .1" Query reply: "0.1 kPa"
Example (classic)	Sent: "HS=0.1" Reply: "0.1 kPa"
Errors	ERR# 6 The ' <i>hold</i> ' argument was invalid.
See Also	"HS%" 3.2.2 , 3.2.13

HS%	
Purpose	Read or set the automated pressure control hold limit for as a percent of range span.
Command	"HS% <i>hold</i> "
Query	"HS%?"
Classic	"HS%= <i>hold</i> " "HS%"
Arguments	<i>hold</i> : The hold limit in % span of the active range.
Remarks	The hold limit can be read and set as a pressure or as a percent of the span.
Example (enhanced)	Cmd sent: "HS .01" Query reply: "0.0100 %" (No reply if IEEE-488)
Example (enhanced)	Cmd sent: "HS? .01" Query reply: "0.0100 %"
Example (classic)	Sent: "HS=.01" Reply: "0.0100 %"
Errors	ERR# 6 The ' <i>hold</i> ' argument was invalid.
See Also	"HS" 3.2.2 , 3.2.13

ID	
Purpose	Read or set the user defined instrument identification label.
Command	"ID string"
Query	"ID"
Classic	"ID=string" "ID"
Arguments	String: An alphanumeric string up to 12 characters long.
Remarks	The user defined ID label can be used to allow the user to "tag" the PPC4 with a unique identifier. This ID is stored in non-volatile memory and cannot be erased by a power failure, system fault or reset
Example (enhanced)	Cmd sent: "ID PPCK #A01" Query reply: "PPCK #A01" (No reply if IEEE-488)
Example (enhanced)	Cmd sent: "ID PPCK? #A01" Query reply: "PPCK #A01"
Example (classic)	Sent: "ID=PPCK #A01" Reply: "PPCK #A01"
Errors	ERR# 6 The ' <i>string</i> ' argument was longer than 12 char.
See Also	3.2.27.1

IF	
Purpose	Increase the pressure quickly (fast).
Command	"IF <i>n</i> "
Classic	"IF= <i>n</i> "
Arguments	<i>n</i> : '0' Closes the fast up valve. '1' Opens the fast up valve.
Remarks	Opening the fast up valve causes the pressure to increase quickly. Care must be used, as the pressure will not stop increasing until the valve is closed, or the upper limit is exceeded.
Example (enhanced)	Cmd sent: "IF 1" Reply: "1" (no reply if IEEE-488)
Example (enhanced)	Cmd sent: "IF? 1" Reply: "1"
Example (classic)	Sent: "IF=1" Reply: "IF=1"
Errors	ERR# 6: The <i>n</i> argument is a '0' or a '1'.
See Also	"DF", "IS", "DS", "IP", "DP", Figure 31

IP	
Purpose	Increase the pressure a given amount using the slow speed.
Command	"IP <i>n</i> "
Classic	"IP= <i>n</i> "
Arguments	<i>n</i> : The increase in pressure desired (current pressure units). This can be from 0 to 2 % FS of the active range.
Remarks	The slow speed will be used for a calculated amount of time (up to 5 seconds) to create the desired change. The PPC4 will not attempt to control the pressure to a target, so the change in pressure will be approximate. This is the equivalent of using  .
Example (enhanced)	Cmd sent: "IP 2" Reply: "2.000 kPa" (no reply if IEEE-488)
Example (enhanced)	Cmd sent: "IP? 2" Reply: "2.000 kPa"
Example (classic)	Sent: "IP=2" Reply: "2.000 kPa"
Errors	ERR# 6: The <i>n</i> argument is not within given limits.
See Also	"DP", "IF", "DF", "IS", "DS" 3.2.1

IS	
Purpose	Increase the pressure slowly.
Command	"IS <i>n</i> "
Classic	"IS= <i>n</i> "
Arguments	<i>n</i> : '0' Closes the slow up valve. '1' Opens the slow up valve.
Remarks	Opening the slow up valve causes the pressure to increase slowly. Care must be used, as the pressure will not stop increasing until the valve is closed, or the upper limit is exceeded.
Example (enhanced)	Cmd sent: "IS 1" Reply: "1" (no reply if IEEE-488)
Example (enhanced)	Cmd sent: "IS? 1" Reply: "1"
Example (classic)	Sent: "IS=1" Reply: "IS=1"
Errors	ERR# 6: The <i>n</i> argument is a '0' or a '1'.
See Also	"DS", "IF", "DF", "IP", "DP" Figure 31

L2 / L3	
Purpose	Read or set the type of program command format to use (classic or enhanced).
Command	"L2" enables "classic" mode "L3" enables "enhanced" mode
Defaults	"L2" (Classic mode)
Remarks	The user can select the type of remote command format using these simplified commands. There is no query format. This format must agree with the format sent to the RPM4. This command is a replacement for the "MSGFMT" command.
Example (enhanced)	Cmd sent: "L3" Query reply: "L3" (No reply if IEEE-488)
Example (classic)	Sent: "L2" Reply: "L2"
See Also	"MSGFMT" 6.4

LL(=)	
Purpose	Read or set the lower pressure limit for the active range and measurement mode (negative gauge measurement mode only).
Command	"LL <i>n</i> "
Classic	"LL= <i>n</i> "
Arguments	<i>n</i> : The lower pressure limit for the current pressure range in the current unit of measure. Value is always a negative value of gauge pressure.
Remarks	Negative gauge mode in PPC4 has a lower limit. New automated pressure control targets can not be less than this value. If the pressure exceeds the lower limit, the pressure display flashes, and pressure control is aborted. Manual decreases in pressure are not allowed as long as the pressure is below the lower limit. Increases in pressure are allowed. This feature should always be used to prevent accidental over (under) pressure of a device under test.
Example (enhanced)	Cmd sent: "LL -4" Reply: "-4 kPa g" (no reply if IEEE-488)
Example (enhanced)	Cmd sent: "LL? -4" Reply: "-4 kPa g"
Example (classic)	Sent: "LL=-4" Reply: "-4 kPa g"
Errors	ERR# 6: The <i>n</i> argument is invalid. ERR# 23: The mode must be negative gauge to specify a lower limit.
See Also	"UL" 3.2.21

LOCAL	
Purpose	Returns control to the PPC4 front panel.
Command	"LOCAL"
Classic	"LOCAL"
Remark	The REMOTE program message can lock the front panel out completely. The user can return to local operation by sending the LOCAL program message, sending the IEEE-488 'GTL' command (if in enhanced format), or by cycling PPC4 power.
Example (enhanced)	Cmd sent: "LOCAL" Reply: "LOCAL" (no reply if IEEE-488)
Example (enhanced)	Cmd sent: "LOCAL?" Reply: "LOCAL"
Example (classic)	Sent: "LOCAL" Reply: "LOCAL"
See Also	"REMOTE"

MEM	
Purpose	Read the status from the power-up memory test.
Query	"MEM?"
Classic	"MEM"
Remarks	The PPC4 system memory stores the user settings (units, resolution, generation settings) and retains them when the unit is OFF. On power-up, this memory is checked. If this memory is corrupted, all user settings are reset to default , and the MEM status will be set to reflect this.
Example (enhanced)	Query sent: "MEM?" Reply: "0" PPC4 data corrupted and was set to factory defaults. "1" The memory was found to be OK on power-up.
Example (classic)	Sent: "MEM" Reply: "MEM=0" PPC4 data corrupted and was set to factory defaults. "MEM=1" The memory was found to be OK on power-up.
See Also	3.2.27.5

MODE	
Purpose	Read or set the automated pressure control mode.
Command	"MODE <i>n</i> "
Query	"MODE?"
Classic	"MODE= <i>n</i> " "MODE"
Arguments	<i>n</i> : '0' for static pressure control. '1' for dynamic pressure control.
Remarks	The method which the PPC4 controls pressure is selected with the "MODE" program message. When the control mode is set, control parameters go to default parameters for that range. The control mode setting is range dependent.
Example (enhanced)	Cmd sent: "MODE 1" Query reply: "1" (No reply if IEEE-488)
Example (enhanced)	Cmd sent: "MODE? 1" Query reply: "1"
Example (classic)	Sent: "MODE=1" Reply: "MODE=1"
Errors	ERR# 6 The argument is invalid.
See Also	"HS", "SS" 3.2.13, 3.2.2

MMODE	
Purpose	Read or change the active measurement mode.
Command	"MMODE= <i>mode</i> "
Query	"MMODE"
Classic	"MMODE= <i>mode</i> " "MMODE "
Arguments	<p><i>Mode:</i></p> <p>"A" Absolute mode "G" Gauge mode "N" Negative gauge mode</p> <p style="text-align: center;">Note</p> <p style="text-align: center;">Measured pressure values are returned with "g" to identify measurement mode for both gauge and negative gauge measurement modes.</p>
Remarks	The active RPT or an AutoRange range should be selected before setting measurement mode since measurement mode is range specific. The measurement mode can also be set using the "UNIT" command but the "UNIT" command does not distinguish between gauge and negative gauge while the "MMODE" does.
Example (enhanced)	Cmd sent: "MMODE A" Query reply: "A" (No reply if IEEE-488)
Example (enhanced)	Cmd sent: "MMODE? A" Query reply: "A"
Example (enhanced)	Cmd sent: "MMODE=G" Query reply: "G"
Errors	<p>ERR# 6: Invalid argument text.</p> <p>ERR# 7: Abs mode only with altitude units or gauge mode only with gauge RPT. Absolute or negative gauge mode not available with gauge RPT or absolute RPT with an absolute and negative gauge OFF calibration. The current range cannot support gauge mode.</p> <p>ERR# 20:</p> <p>ERR# 53: Not available.</p>
See Also	"UNIT" 3.2.11

MSGFMT	
Purpose	Read or set the type of program command format to use (enhanced or classic).
Command	"MSGFMT <i>n</i> "
Query	"MSGFMT?"
Classic	"MSGFMT= <i>n</i> " "MSGFMT"
Arguments	<p><i>n:</i></p> <p>'1' to use the enhanced command format. '0' to use the classic command format.</p>
Defaults	"MSGFMT 0"
Remarks	<p>The user can select the type of remote command format to use. This format must agree with the format sent to the PPC4.</p> <p>The enhanced query form of this command ("MSGFMT? <i>n</i>") should always be used to set the desired format, as it will be accepted regardless of the current format (classic or enhanced).</p>
Example (enhanced)	Cmd sent: "MSGFMT 1" Query reply: "1" (No reply if IEEE-488)
Example (enhanced)	Cmd sent: "MSGFMT? 1" Query reply: "1"
Example (classic)	Sent: "MSGFMT=1" Reply: "MSGFMT=1"
Errors	ERR# 6: Missing or improper program message argument(s).
See Also	6.4

NVENT	
Purpose	Read or set the status of TEST (-) (negative) vent valve (Gxxx or BGxxx Q-RPT only)
Command	"NVENT <i>n</i> "
Query	"NVENT?"
Classic	"NVENT= <i>n</i> " "NVENT"
Default	"NVENT AUTO"
Arguments	<i>n</i> : '0' to close the low vent valve. '1' to open the low vent valve. 'AUTO' for the PPC4 to automatically open and close the low vent valve.
Remarks	A PPC4 with at least one Gxxx or BGxxx Q-RPT has a valve that is used to vent the TEST (-) port. This valve is normally controlled automatically depending on current PPC4 operation but it can be commanded to open or close using the "NVENT" command. The PPC4 may not immediately open the negative vent valve when commanded to do so, as it checks to make sure that such an action will not cause harm to the low pressure Q-RPT. The reply includes two fields. The first indicates the low vent status. The second indicates whether the low vent function is AUTO or MANUAL
Example (enhanced)	Cmd sent: "NVENT 0" Query reply: "0, MANUAL"
Example (enhanced)	Cmd sent: "NVENT? AUTO" Query reply: "1, AUTO"
Example (classic)	Sent: "NVENT=1" Query reply: "0, MANUAL"
See Also	"VENT" 3.2.27.6

PASSTHRU	
Purpose	To allow the host PC to communicate with a device connected to the PPC4 COM2 port.
Command	"PASSTHRU <i>n</i> "
Query	"PASSTHRU?"
Classic	"PASSTHRU= <i>n</i> " "PASSTHRU"
Arguments	<i>n</i> : The string to send out of the COM2 port. It must be less than 40 characters long.
Remarks	Generally, the PPC4 COM2 port is used for communication with DHI RPM4s used as PPC4 external measurement devices. The COM2 port can alternatively be used to communicate to another RS232 device (such as another PPC4). This allows the user to use one COM port or IEEE-488 port on the host computer to communicate with the PPC4 and another device. The Command format specifies and sends the argument. A carriage return and a line feed (<CR><LF>) are added to the string that is sent. The Query format is used to check the PPC4 COM2 receive buffer to see if a message has been received on COM2 from the device. The message received by the COM2 port must be terminated with a carriage return or a carriage return and a line feed. Only one message is retained by the COM2 port. The label "COM2:" precedes the message text. If the COM2 receive buffer is empty, then the reply is just be "COM2:"
Example (enhanced)	Cmd sent: "PASSTHRU VER" Query reply: "COM2:DH INSTRUMENTS, INC PPC4 VER1.01a" Query reply: "COM2:" (If the COM2 buffer is empty)
Example (classic)	Sent: "PASSTHRU=VER" Reply: "COM2:DH INSTRUMENTS, INC PPC4 VER1.01a" Reply: "COM2:" (If the COM2 buffer is empty)
See Also	"#", "COM2" 6.3.1.1, 6.3.1.2

PCAL:IH and PCAL:IL	
Purpose	Read or set the Q-RPT or utility sensor calibration information for the "IH" (internal high) and "IL" (internal low) RPTs. "IH" is equivalent to "IuH".
Command	"PCAL:IH <i>adder, mult, CalDate, (GaOnly)</i> " "PCAL:IL <i>adder, mult, CalDate, (GaOnly)</i> "
Query	"PCAL:IH?" "PCAL:IL?"
Classic	"PCAL:IH= <i>adder, mult, CalDate, (GaOnly)</i> " "PCAL:IL= <i>adder, mult, CalDate, (GaOnly)</i> " "PCAL:IH" "PCAL:IL"
Defaults	"PCAL:IH = 0.0, 1.0, 19800101, 0" "PCAL:IL = 0.0, 1.0, 19800101, 0"
Arguments	<p><i>Adder</i>: The RPT calibration adder (PA). In Pascal.</p> <p><i>Mult</i>: The RPT calibration multiplier (PM) from 0.1 to 100.</p> <p><i>CalDate</i>: The date of the calibration in the format "YYYYMMDD" by default. The format "YYMMDD" is also be accepted, and the replied format is in the previously entered format.</p> <p><i>GaOnly</i>: Optional "Gauge only" flag. Indicates that the an Axxx Q-RPT is set to operate in gauge measurement mode only. This field does not apply and is ignored for Gxxx and BGxxx Q-RPTs or utility sensors.</p> <p>'0' Absolute, negative gauge and gauge modes are available.</p> <p>'1' Gauge mode only.</p>
Remarks	<p>The user defined pressure calibration information for the specified RPT (IH or IL pressure) can be accessed with this program message. Using this program message overwrites the current calibration coefficients, so caution must be used. If the "<i>GaMode</i>" flag is set and the RPT is an Axxx Q-RPT, then the RPT will only be allowed to operate in gauge mode. Changes made using this program message take effect immediately.</p> <p>The calibration information of DHI RPM4s connected to PPC4 must be adjusted directly on the RPM4. The information cannot be adjusted through the PPC4.</p>
Example (enhanced)	<p>Cmd sent: "PCAL:LO 2.1, 1.000021, 20011201, 0"</p> <p>Query reply: " 2.10 Pa, 1.000021, 20011201, 0" (No reply if IEEE-488)</p>
Example (enhanced)	<p>Cmd sent: "PCAL:LO? 2.1, 1.000021, 20011201, 0"</p> <p>Query reply: " 2.10 Pa, 1.000021, 20011201, 0"</p>
Example (classic)	<p>Sent: "PCAL:LO=2.1, 1.000021, 20011201, 1"</p> <p>Reply: " 2.10 Pa, 1.000021, 20011201, 1"</p>
Errors	ERR# 6: One of the arguments is out of range.
See Also	7.2

PCALUNC:IH and PCALUNC:IL	
Purpose	Read or set the Q-RPT uncertainty settings used to determine the RPT's measurement uncertainty during operation.
Command	"PCALUNC:IH <i>Reading, Span, Scale, Head, StabAZon, StabAZoff</i> " "PCALUNC:IL <i>Reading, Span, Scale, Head, StabAZon, StabAZoff</i> "
Query	"PCALUNC:IH?" "PCALUNC:IL?"
Classic	"PCALUNC:IH= <i>Reading, Span, Scale, Head, StabAZon, StabAZoff</i> " "PCALUNC:IL= <i>Reading, Span, Scale, Head, StabAZon, StabAZoff</i> " "PCALUNC:IH" "PCALUNC:IL"
Defaults	"PCALUNC:IH = 0.0080, 0.0024, 30, 0.00, 0.0000, 0.005" (Premium Q-RPT) "PCALUNC:IH = 0.0100, 0.0030, 100, 0.00, 0.0000, 0.005" (Standard Q-RPT) "PCALUNC:IH = 0.0, 0.015, 30, 0.00, 0.0000, 0.005" (Full Scale Standard Q-RPT) "PCALUNC:IH = 0.0, 0.015, 10, 0.00, 0.0000, 0.005" (Full Scale Standard Q-RPT BG or G) "PCALUNC:IL = 0.0080, 0.0024, 30, 0.00, 0.0000, 0.005" (Premium Q-RPT) "PCALUNC:IL = 0.0100, 0.0030, 100, 0.00, 0.0000, 0.005" (Standard Q-RPT) "PCALUNC:IL = 0.0, 0.015, 30, 0.00, 0.0000, 0.005" (Full Scale Standard Q-RPT) "PCALUNC:IL = 0.0, 0.015, 10, 0.00, 0.0000, 0.005" (Full Scale Standard Q-RPT BG or G)
Arguments	<i>Reading:</i> The % of reading uncertainty component (%). <i>Span:</i> The % of range span uncertainty component (%). <i>Scale:</i> The minimum scaling limit (%). <i>Head:</i> The uncertainty head height in the current head units. <i>StabAZon:</i> The stability uncertainty component when auto zero is ON. <i>StabAZoff:</i> The stability uncertainty component when auto zero is OFF.
Remarks	Use the PPC4 uncertainty function to obtain a re-time update of delivered, or measured pressure uncertainty. The uncertainty feature is available for Q-RPTs only.
Example (enhanced)	Cmd sent: "PCALUNC:IH=.005, .001, 50, 0, 0, .01" Query reply: "0.0050, 0.0010, 50.0, 0.00, 0.0000, 0.0100" (No reply if IEEE-488)
Example (classic)	Sent: "PCALUNC:IL= .005, .001, 50, 0, 0, .01" Reply: "0.0050, 0.0010, 50.0, 0.00, 0.0000, 0.0100"
Errors	ERR# 6: One of the arguments is out of range.
See Also	"DISPUNC" command "HEAD" command 3.2.29, 7.2.7.3

PR	
Purpose	Read the next available pressure.
Query	"PR?"
Classic	"PR"
Remarks	The next available pressure value for the active Q-RPT or utility sensor is read in the current pressure units. The data returned also contains <i>Ready/Not Ready</i> information, and the pressure unit of measure and measurement mode. The reply field is always 20 characters long. The first 3 characters of the reply are reserved for the ready status (R or NR). The ready status is described in the "SR" program message. The pressure value and pressure unit of measure are right justified in this field. After receiving this program message, the PPC4 replies back with the data after a new pressure measurement cycle is complete. This can take up to 1.5 seconds.
Example (enhanced)	Query sent: "PR?" Query reply: "R 1936.72 kPaa"
Example (classic)	Query sent: "PR" Reply: "R 1936.72 kPaa"
See Also	"PRR", "QPRR", "SR" 3.2.3

PRR	
Purpose	Read the next available pressure, rate, on-board barometer reading, control status, and the QRPT uncertainty.
Query	"PRR?"
Classic	"PRR"
Remarks	<p>The next available <i>Ready</i> condition, Q-RPT or utility sensor pressure, rate of pressure change, barometric pressure, generation status and Q-RPT uncertainty is replied in the current pressure unit of measure. Each data field is separated by a comma, and is returned in the following order up to 1.2 seconds after the command is received:</p> <p style="padding-left: 40px;">ready, pressure UNITS, rate UNITS/s, atm UNITS, status, uncert UNITS</p> <p>Here are the field descriptions:</p> <p>ready: 'R' if the current pressure <i>Ready</i> criteria has been met, 'NR' if the criteria has not been met (see the "SR" program message).</p> <p>pressure: The measured pressure for the active Q-RPT or utility sensor in the current pressure unit. This is followed by the current pressure unit.</p> <p>rate: The measured rate of pressure change for the active Q-RPT or utility sensor in the current pressure unit per second. This is followed by the current pressure unit of measure.</p> <p>atm: The pressure measured by the PPC4 on-board barometer in the current pressure unit (and always absolute). This is followed by the current pressure unit. Not all PPC4s are equipped with an on-board barometer. This field is "NONE" if the PPC4 is not equipped with an on-board barometer.</p> <p>status: Generation status. Similar to the reply of the STAT command. Can be a sum of the following states::</p> <p style="padding-left: 40px;">0 The system is not generating or holding a pressure or vented. 1 A new generation is preparing to start. 2 Quick ramping to the target. 4 Quick pulsing to the target. 8 Slow ramping to the target. 16 Slow pulsing to the target. 32 Reached the target, will re-adjust as needed to stay ready. 64 Quick ramping to a vent condition. 128 Executing a purge operation. 256 Quickly decreasing the pressure to reach a hard vacuum. 512 System is vented 1024 A new target has been requested but generation has not started. 2048 PWM low pressure control 4096 Dynamic pulsing is being used to control a pressure. 8291 Static pulsing is being used to control a pressure. 16394 Low pressure pulsed control is active. 32768 Very low pressure pulsed control is active. 65536 Determining external volume</p> <p>uncert: The uncertainty is calculated as the measured uncertainty or the delivered uncertainty, depending on the current setting as determined by the DISPUNC command. Always returned as '0' for utility sensors.</p>
Example (enhanced)	<p>Query sent: "PRR?"</p> <p>Query reply: "R,2306.265 kPaa,0.011 kPa/s,97.000 kPaa, 0, 0.0034 kPa" "R,2306.265 kPaa,0.011 kPa/s, NONE, 0, 0.0034 kPa" (no barometer)</p>
Example (classic)	<p>Query sent: "PRR"</p> <p>Reply: "R,2306.265 kPaa,0.011 kPa/s,97.000 kPaa, 0, 0.0034 kPa"</p>
See Also	"PR", "QPRR", "SR", "DISPUNC" 3.2.2, 3.2.27.3, 3.2.29

PS	
Purpose	Set a new target pressure and start a new pressure generation cycle. Allows the test volume to be specified which causes the pressure generation cycle to be executed omitting the automated control configuration routine.
Command	"PS <i>n</i> (<i>v</i>)"
Classic	"PS= <i>n</i> (<i>v</i>)"
Arguments	<i>n</i> : The target pressure in the current pressure units. <i>v</i> : The volume of the system connected to the PPC4 TEST(+) port in cm ³ (cc). This argument is optional and should be used only to reduce pressure setting time in know volumes.
Remarks	The PPC4 sets the specified target pressure using the current control settings and mode. Control continues until a new target pressure is set, the PPC4 goes into LOCAL mode, or an "ABORT" program message is executed. If the given target is '0' and the pressure units are gauge, the PPC4 vents. The "PR?", "PRR?", "STAT?", or "SR?" program message queries can be used to monitor the progress of the pressure setting routine. If the optional "v" argument is used, the PPC4 does not perform its test volume determination routine at the beginning of the pressure setting procedure, but instead uses the volume specified for the pressure generation. This can reduce pressure set times when operating into a consistent volume since the configuration routine takes 5 to 6 seconds to execute. The "v" argument should only be used in automated conditions, where the test volume is constant and the configuration does not change. This argument is only an approximation value, and it may be adjusted empirically for correct operation. A higher "v" setting speeds up the generation with a higher risk of significant control overshoot. A lower "v" setting slows down the generation and reduces overshoot. Note: When using a BG15K or G15K low gauge pressure Q-RPT with a DVU, the volume size specified should NOT include the DVU volume.
Example (enhanced)	Cmd sent: "PS 1000" Reply: "1000.000 kPa a " (no reply if IEEE-488)
Example (enhanced)	Cmd sent: "PS? 1000" Reply: "1000.000 kPa a "
Example (classic)	Sent: "PS=1000, 75" (includes test volume definition) Reply: "1000.000 kPa a "
Errors	ERR# 6 The target pressure is out of range.
See Also	"PR", "PRR", "STAT", "SR", "QPRR" 3.2.2, 3.2.12

PSF	
Purpose	Set a new target pressure, using only the fast control valve(s) and aborting pressure control once the pressure target is reached..
Command	"PSF <i>n</i> "
Classic	"PSF= <i>n</i> "
Arguments	<i>N</i> : The target pressure in the current pressure unit of measure.
Remarks	The PPC4 sets the given target pressure using just the fast speed, and stops controlling when the pressure has reached or passed the given target. The system does not attempt to maintain the target pressure. The "PR?", "PRR?", "STAT?", or "SR?" program message queries can be used to monitor the progress of the generation.
Example (enhanced)	Cmd sent: "PSF 1000" Reply: "1000.000 kPaa (no reply if IEEE-488)
Example (classic)	Sent: "PSF=1000" Reply: "1000.000 kPaa
Errors	ERR# 6 The target pressure is out of range.
See Also	"PR", "PRR", "STAT", "SR", "PSS", "PS" Figure 31

PSS	
Purpose	Set a new target pressure using only the slow control valve(s) and aborting pressure control once the target is reached.
Command	"PSS <i>n</i> "
Classic	"PSS= <i>n</i> "
Arguments	<i>N</i> : The target pressure in the current pressure units.
Remarks	The PPC4 sets the given target pressure using just the slow speed, and stops controlling when the pressure has reached or passed the given target. The system does not attempt to maintain the target pressure. The "PR?", "PRR?", "STAT?", or "SR?" program message can be used to monitor the progress of the generation.
Example (enhanced)	Cmd sent: "PSS 1000" Reply: "1000.000 kPaa" (no reply if IEEE-488)
Example (enhanced)	Cmd sent: "PSS? 1000" Reply: "1000.000 kPaa"
Example (classic)	Sent: "PSS=1000" Reply: "1000.000 kPaa"
Errors	ERR# 6 The target pressure is out of range.
See Also	"PR", "PRR", "STAT", "SR", "PSF", "PS" Figure 31

QPRR	
Purpose	Quickly read the last known pressure, rate, on-board barometer reading, control status and QRPT uncertainty.
Query	"QPRR?"
Classic	"QPRR"
Remarks	<p>The last known <i>Ready</i> condition, Q-RPT or utility sensor pressure, rate of pressure change, barometric pressure, generation status and Q-RPT uncertainty is replied in the current pressure unit of measure. Each data field is separated by a comma, and is returned in the following order:</p> <p style="padding-left: 40px;">ready, pressure UNITS, rate UNITS/s, atm UNITS, status, uncert UNITS</p> <p>Here are the field descriptions:</p> <p>ready: 'R' if the current pressure <i>Ready</i> criteria has been met, 'NR' if the criteria has not been met (see the "SR" program message).</p> <p>pressure: The measured pressure for the active Q-RPT or utility sensor in the current pressure unit. This is followed by the current pressure unit.</p> <p>rate: The measured rate of pressure change for the active Q-RPT or utility sensor in the current pressure unit per second. This is followed by the current pressure unit of measure.</p> <p>atm: The pressure measured by the PPC4 on-board barometer in the current pressure unit (and always absolute). This is followed by the current pressure unit. Not all PPC4s are equipped with an on-board barometer. This field is "NONE" if the PPC4 is not equipped with an on-board barometer.</p> <p>status: Generation status. Similar to the reply of the STAT command. Can be a sum of the following states:</p> <ul style="list-style-type: none"> 0 The system is not generating or holding a pressure or vented. 1 A new generation is preparing to start. 2 Quick ramping to the target. 4 Quick pulsing to the target. 8 Slow ramping to the target. 16 Slow pulsing to the target. 32 Reached the target, will re-adjust as needed to stay ready. 64 Quick ramping to a vent condition. 128 Executing a purge operation. 256 Quickly decreasing the pressure to reach a hard vacuum. 512 System is vented 1024 A new target has been requested but generation has not started. 2048 PWM low pressure control 4096 Dynamic pulsing is being used to control a pressure. 8291 Static pulsing is being used to control a pressure. 16394 Low pressure pulsed control is active. 32768 Very low pressure pulsed control is active. 65536 Determining external volume <p>uncert: The uncertainty is calculated as the measured uncertainty or the delivered uncertainty, depending on the current setting as determined by the DISPUNC command. Always returned as '0' for utility sensors.</p>
Example (enhanced)	<p>Query sent: "QPRR?"</p> <p>Query reply: "R,2306.265 kPaa,0.011 kPa/s,97.000 kPaa, 0, 0.0034 kPa" "R,2306.265 kPaa,0.011 kPa/s, NONE, 0, 0.0034 kPa" (no barometer)</p>
Example (classic)	<p>Query sent: "QPRR"</p> <p>Reply: "R,2306.265 kPaa,0.011 kPa/s,97.000 kPaa, 0, 0.0034 kPa"</p>
See Also	<p>"PR", "PRR", "SR", "DISPUNC"</p> <p>3.2.2, 3.2.27.3, 3.2.29</p>

RANGE (PPC4 version)	
Purpose	Change the active range to one of the available internal or external default RPT ranges. Read the active range full scale, pressure unit and measurement mode.
Command	"RANGE <i>Rng</i> "
Query	"RANGE?"
Classic	"RANGE= <i>Rng</i> " "RANGE "
Default	"RANGE IH" <i>Rng</i> : "IH" for the internal, hi Q-RPT or utility sensor "IL" for the internal lo Q-RPT "X1H" for the first external RPM4, hi Q-RPT "X1L" for the first external RPM4, lo Q-RPT
Remarks	The active RPT must be selected before making changes to settings that are dependent on the range. The system MUST BE VENTED to change active RPTs. RPTs selected with this command are used with their full default pressure range. External RPTs must be found and initialized using the "RPT" command or function key before the can be selected The reply indicates the active range in psi if the PPC4 is a "US" version or in kPa if the PPC4 is an "SI" version. Used as a simple query, the active range is returned, which can be an AutoRanged range or a default range (see "ARANGE" cmd).
Example (enhanced)	Cmd sent: "RANGE IL" (select internal Lo Q-RPT in it's full default range) Query reply: "50 psia" (no response in IEEE-488)
Example (classic)	Sent: "RANGE=IH" (select internal Hi Q-RPT in it's full default range) Reply: "1000 psia"
Example (classic)	Sent: "RANGE=X2H" (select external 2 nd RPM4, Hi Q-RPT) Reply: "500 psia"
Example (classic)	Sent: "RANGE" (request current range) Reply: "220 psia"
Errors	ERR# 6: Invalid <i>Rng</i> argument. ERR# 22: System must be vented for the requested operation. ERR# 38: The selected RPT is not available.
See Also	"ARANGE", "RPT" 3.2.6, 3.2.9, 3.2.8,

RATE	
Purpose	Read the next available pressure rate of change.
Query	"RATE?"
Classic	"RATE"
Remarks	The next available pressure rate of change in the current pressure unit per second is returned. After receiving this program message, the PPC4 replies back with the data once a new pressure measurement cycle is complete. This can take up to 1.5 seconds.
Example (enhanced)	Query sent: "RATE?" Query reply: "0.01 kPa/s"
Example (classic)	Sent: "RATE" Reply: "0.01 kPa/s"
See Also	"PRR", "QPRR"

READYCK	
Purpose	Read or set the <i>Ready</i> check flag.
Command	"READYCK 1"
Query	"READYCK?"
Classic	"READYCK=1" "READYCK"
Remarks	The internal ready check flag is cleared whenever the PPC4 reaches a <i>Not Ready</i> (NR) condition. The "READYCK" query returns the status of the flag. The flag is set by sending the "READYCK 1" program message while the PPC4 is in a <i>Ready</i> condition. The "READYCK" program message query can then be used at a later time to determine whether a <i>Not Ready</i> condition has occurred since the ready check flag was set.
Example (enhanced)	Cmd sent: "READYCK 1" Query reply: "1" (no reply if IEEE-488)
Example (enhanced)	Cmd sent: "READYCK?" Query reply: "1"
Example (enhanced)	Cmd sent: "READYCK?" Query reply: "1" (if PPC4 condition has stayed <i>Ready</i>) "0" (if PPC4 condition has NOT stayed <i>Ready</i>)
Example (classic)	Sent: "READYCK=1" Query reply: "READYCK=1"
Example (classic)	Sent: "READYCK" Query reply: "READYCK=1" (if PPC4 condition has stayed <i>Ready</i>) "READYCK=0" (if PPC4 condition has NOT stayed <i>Ready</i>)
Errors	ERR# 6: Argument is not a '0' or a '1'.
See Also	"SR" 3.2.3

REMOTE	
Purpose	Lock out the front panel keypads during remote operation.
Command	"REMOTE"
Classic	"REMOTE"
Remarks	The PPC4 goes into remote mode whenever communications take place. The user can return to local operation by pressing Esc . The REMOTE program message locks out the front panel completely. The only way to unlock the front panel after the "REMOTE" command is using the "LOCAL" program message, the IEEE-488 "GTL" command, or by cycling the PPC4 power.
Example (enhanced)	Cmd sent: "REMOTE" Reply: "REMOTE" (no reply if IEEE-488)
Example (enhanced)	Cmd sent: "REMOTE?" Reply: "REMOTE"
Example (classic)	Sent: "REMOTE" Reply: "REMOTE"
See Also	"LOCAL"

RES	
Purpose	To read or set the pressure display resolution for the active range.
Command	"RES <i>n</i> "
Query	"RES"
Classic	"RES= <i>n</i> " "RES"
Default	"RES 0.001"
Arguments	<i>n</i> : The pressure display resolution in % span of the current RPT range (0.0001 to 1 % FS).
Remarks	The pressure display resolution is defined as % span of the active range. The setting is separate for each range, and changes as the range is changed.
Example (enhanced)	Cmd sent: "RES .01" Query reply: "0.01" (No reply if IEEE-488)
Example (enhanced)	Cmd sent: "RES? .01" Query reply: "0.01"
Example (classic)	Sent: "RES=.01" Reply: "0.01"
Errors	ERR# 6 The argument is invalid.
See Also	3.2.19

RESET	
Purpose	Reset the user's settings to factory defaults.
Command	"RESET"
Classic	"RESET"
Remarks	The PPC4 has user settings (units, resolution, control modes, etc.) that can be reset to factory defaults. System calibration coefficients and communications settings are not affected. The remote "RESET" program message corresponds to the front panel "Reset Settings." The reset cycle takes up to 5 seconds to complete and involves a power cycle of the PPC4. Remote communications should not take place during this period.
Example (enhanced)	Cmd sent: "RESET" Reply: "RESET" (no reply if IEEE-488)
Example (enhanced)	Cmd sent: "RESET?" Reply: "RESET"
Example (classic)	Sent: "RESET" Reply: "RESET"
See Also	3.2.25.1

RETURN	
Purpose	Start a new pressure setting sequence equivalent to the "PS" command using the last target pressure.
Command	"RETURN"
Classic	"RETURN"
Remarks	The "RETURN" program message starts a new pressure setting sequence using the current settings and target pressure. Pressure control continues until a new target pressure is set, the PPC4 is put into LOCAL mode, or an "ABORT" program message is executed.
Example (enhanced)	Cmd sent: "RETURN" Reply: "1000.000 kPaa" (no reply if IEEE-488)
Example (classic)	Sent: "RETURN" Reply: "1000.000 kPaa"
Errors	ERR# 6 The current target pressure is invalid.
See Also	"PS", "TP" 3.2.12

RPT(n)	
Purpose	Read the available Q-RPT data or initiate the Q-RPT search and initialize process.
Command	"RPT"
Query	"RPT(n)"
Classic	"RPT" "RPT(n)"
Default	"RPT"
Prefix (optional)	<i>n</i> Specify the position locator of the RPT about which to collect information: '1' The internal, Hi RPT '2' The internal, Lo, Q-RPT '3' The first external RPM4, Hi Q-RPT '4' The first external RPM4, Lo Q-RPT
Remarks	<p>Up to four Q-RPTs can be available for use in one PPC4 system. Two of these can be internal, and the other two are external. These Q-RPTs must be identified and initialized before they can be used by the PPC4. This command allows the search process to be executed (by omitting the prefix 'n') and allows review of the Q-RPTs identified. Note that the search process can take up to 10 seconds to complete, and that the communications settings for the PPC4's COM2 port and the external RPM4 devices should be setup prior to this. If you are querying the unit for information about a particular Q-RPT Using the prefix 'n', then the Q-RPT data found during the execution of the last search is returned in the following format:</p> <p><i>RPTType, RPTLocator, Serial#, RngGa, RngAbs, RptMode</i></p> <p><i>RngLabe:</i> RPT type label. This label identifies the RPT type and range. This is the same label used on the PPC4 front panel screen.</p> <p><i>RptLocator:</i> Text field identifying the Q-RPT position in the PPC4 system. "IH" identifies this as an internal, Hi Q-RPT "luH" identifies this as an internal, Hi utility sensor "IL" identifies this as an internal, Lo Q-RPT "X1H" identifies this as the first external RPM4, Hi Q-RPT "X1H" identifies this as the first external RPM4, Lo Q-RPT</p> <p><i>Serial#:</i> The serial number of the PPC4 or RPM4 in which the Q-RPT is located.</p> <p><i>RngGa:</i> The Q-RPT gauge mode range in the current pressure unit.</p> <p><i>RngAbs:</i> The Q-RPT absolute mode range in the current pressure unit. "NONE" appears in the field if the Q-RPT is a Gxxx, BGxxx or Axxx with absolute and negative gauge modes OFF.</p> <p><i>RptMode:</i> 'A' if Q-RPT is Axxx and supports absolute, gauge and negative gauge measurement modes. 'G' if Q-RPT is gauge Gxxx or Axxx with absolute and negative gauge modes OFF and supports only gauge measurement mode. 'N' if Q-RPT is BGxxx and supports gauge and negative gauge measurement modes.</p>
Example (enhanced)	Cmd sent: "RPT?" (find external Q-RPTs in RPM4(s)) Query reply: "OK" (takes up to 10 seconds to reply)
Example (classic)	Cmd sent: "RPT" (find external Q-RPTs in RPM4(s)) Query reply: "OK" (takes up to 10 seconds to reply)
Example (enhanced)	Cmd sent: "RPT2?" (Get information on internal, Lo Q-RPT) Query reply: "A350K, IL, 82345, 35, 50,A"
Example (classic)	Cmd sent: "RPT6" (Get information on Q-RPT in ext RPM4, Lo position) Query reply: "A7M, IH, 82345, 1000, 1000,A"
Errors	ERR# 4: RPT not previously found ERR# 10: Invalid prefix.
See Also	"ARANGE", "COM2" 3.2.5, 3.2.8

SCRSV	
Purpose	Read or set the front panel display screen saver activation time & type.
Command	"SCRSV <i>n,t</i> "
Query	"SCRSV?"
Classic	"SCRSV= <i>n, t</i> " "SCRSV"
Arguments	<i>n</i> : The inactivity period. (minutes) after which screen saver activates. <i>t</i> : Optional screen saver type (GUI only): '0' Moving pressure screen saver '1' DHI screen saver
Default	"SCRSV 10, 0"
Remarks	The PPC4 front panel will dim basic display or switch the GUI to a screen saver pattern after a period of keyboard and remote inactivity. Setting this value to '0' disables this feature.
Example (enhanced)	Cmd sent: "SCRSV 30, 1" Query reply: "30, 1" (No reply if IEEE-488)
Example (enhanced)	Cmd sent: "SCRSV? 30" Query reply: "30, 0"
Example (classic)	Sent: "SCRSV=30, 0" Reply: "30, 0"
Errors	ERR# 6 The argument was invalid.
See Also	3.2.26.1

SN	
Purpose	To read the serial number of the PPC4.
Query	"SN?"
Classic	"SN"
Remarks	The PPC4 is serialized. The serial number can be read using this program message.
Example (enhanced)	Query sent: "SN?" Query reply: "321"
Example (classic)	Sent: "SN" Reply: "321"
See Also	3.2.27.1

SR	
Purpose	Read the next available <i>Ready/Not Ready</i> status.
Query	"SR?"
Classic	"SR"
Remarks	The current <i>Ready</i> status can be read using this program message. Possible replies: "NR" The pressure is Not Ready within the limits defined by the control mode and current control parameters. "R " The pressure meets the ready criteria. The status is replied when the next pressure measurement is finished. "OL" The pressure of one of the active Q-RPTs has exceeded the user defined upper or lower limits. "OP" The pressure of one of the Q-RPTs has exceeded the Q-RPT's maximum limits. "ER" An internal device failure has occurred.
Example (enhanced)	Query sent: "SR?" Query reply: "NR"
Example (classic)	Sent: "SR" Reply: "NR"
See Also	"PR", "PRR", "HS", "SS", "UL", "LL" Commands 3.2.3, 3.2.21, 3.2.21.1

SS%	
Purpose	Read or set the current stability limit as a % of range.
Command	"SS% n"
Query	"SS%?"
Classic	"SS%=n" "SS%"
Arguments	n: The stability limit in %FS of the current active range.
Remarks	The stability limit can be read and set as a percent of the full scale range of the Q-RPT range. If this program message is used to set the stability limit, the PPC4 will then use CUSTOM control settings.
Example (enhanced)	Cmd sent: "SS% .1" Query reply: "0.10 %" (No reply from IEEE-488)
Example (enhanced)	Cmd sent: "SS%? .1" Query reply: "0.10 %"
Example (classic)	Sent: "SS%=.1" Reply: "0.10 %"
Errors	ERR# 6 The argument was invalid.
See Also	"SS" 3.2.13

SS	
Purpose	Read or set the current pressure stability limit.
Command	"SS n"
Query	"SS?"
Classic	"SS=n" "SS"
Arguments	N: The stability limit in the current pressure unit of measure.
Remarks	The stability limit can be read and set as a pressure. The stability limit is used as the <i>Ready/Not Ready</i> criterion in static control mode and when PPC4 not controlling.
Example (enhanced)	Cmd sent: "SS .1" Query reply: "0.10 kPa/s" (No reply from IEEE-488)
Example (enhanced)	Cmd sent: "SS? .1" Query reply: "0.10 kPa/s"
Example (classic)	Sent: "SS=.1" Reply: "0.10 kPa/s"
Errors	ERR# 6 The argument was invalid.
See Also	"HS" 3.2.13

STAT	
Purpose	Read the pressure control status.
Query	"STAT?"
Classic	"STAT"
Remarks	<p>The pressure control cycle status can be checked using this program message. The reply is a numeric code which references a specific pressure control action: Multiple codes are returned by adding them together.</p> <ul style="list-style-type: none"> 0 The system is not generating or holding a pressure. 1 A new generation is preparing to start. 2 Quick ramping to the target. 4 Quick pulsing to the target. 8 Slow ramping to the target. 16 Slow pulsing to the target. 32 Reached the target, will re-adjust as needed to stay ready. 64 Quick ramping to a vent condition. 128 Executing a purge operation. 256 Quickly decreasing the pressure to reach a hard vacuum. 1024 A new target has been requested but generation has not started. 2048 PWM low pressure control 4096 Dynamic pulsing is being used to control a pressure. 8192 Static pulsing is being used to control a pressure. 16394 Low pressure pulsed control is active. 32768 Very low pressure pulsed control is active. 65536 Determining external volume
Example (enhanced)	Query sent: "STAT?" Query reply: "32"
Example (classic)	Sent: "STAT" Reply: "32"
See Also	"PS" 3.2.2, 3.2.12

TIME	
Purpose	Read or set the PPC4 internal clock.
Purpose	Read or set the PPC4 internal clock.
Command	"TIME hh:mm:ssXX" or "TIME hh:mm:ss"
Query	"TIME?"
Classic	"TIME=hh:mm:ssXX" or "TIME=hh:mm:ss" "TIME"
Arguments (12 hour mode)	<i>hh:mm:</i> The time in a 12 hour format using a colon delimiter. <i>XX:</i> "am" or "pm"
Arguments (24 hour mode)	<i>hh:mm:</i> The time in a 24 hour format using a colon delimiter
Remarks	The PPC4 has an internal real time clock. It is used for date stamping calibrations and log data. The TIMEFMT command can be used to set the clock for 12hr or 24hr mode
Example (enhanced 12hr)	Cmd sent: "TIME 12:52PM" Query reply: "12:52pm" (No reply if IEEE-488)
Example (enhanced 12hr)	Cmd sent: "TIME? 12:52PM" Query reply: "12:52pm"
Example (classic 12hr)	Sent: "TIME=12:52PM" Reply: "12:52pm"
Example (classic 24hr)	Sent: "TIME=18:22" Reply: "18:22"
Errors	ERR# 7: Missing or improper program message argument(s).
See Also	"TIMEFMT", "DATE" 3.2.26.3

TIMEFMT	
Purpose	Read or set the clock time format.
Command	"TIMEFMT <i>n</i> "
Query	"TIMEFMT?"
Classic	"TIMEFMT= <i>n</i> " "TIMEFMT"
Arguments	<i>n</i> : '0' 12 hour format '1' 24 hour format
Default	"TIMEFMT 0"
Remarks	The real time clock can be set to report time in either a 12 hour or a 24 hour format.
Example (enhanced)	Cmd sent: "TIMEFMT 1" Query reply: "1" (No reply if IEEE-488)
Example (enhanced)	Cmd sent: "TIMEFMT? 1" Query reply: "1"
Example (classic)	Sent: "TIMEFMT=0" Reply: "TIMEFMT=0"
Errors	ERR# 6 The argument was invalid.
See Also	"TIME" 3.2.26.3

TP	
Purpose	To read the current target pressure.
Query	"TP?"
Classic	"TP"
Remarks	The current target pressure is replied in the current pressure unit of measure.
Example (enhanced)	Query sent: "TP?" Query reply: "1000.00 kPa a"
Example (classic)	Sent: "TP" Reply: "1000.00 kPa a"
See Also	"PS" 3.2.2

UCOEF	
Purpose	To convert 1 Pascal to the current pressure units.
Query	"UCOEF?"
Classic	"UCOEF"
Remarks	The PPC4 handles all pressure values internally in Pascal. The coefficient replied is equivalent of 1 Pa in the current pressure unit of measure. This program message allows the user to convert pressures
Example (enhanced)	Query sent: "UCOEF?" Query reply: "0.0010000000 kPa"
Example (classic)	Sent: "UCOEF" Reply: "0.0010000000 kPa"
See Also	3.2.10, 9.2.1

UDUn	
Purpose	Read or set the user defined pressure units.
Command	"UDUn <i>label, ucoef</i> "
Query	"UDUn?"
Classic	"UDUn= <i>label, ucoef</i> " "UDUn" <i>label</i> : User unit label (5 alphanumeric char maximum). It cannot be an already supported unit label. <i>ucoef</i> : "User unit conversion coefficient (units/Pa).
Arguments	<i>n</i> : The optional user defined unit to access (1 to 5). Assumes '1' if not given.
Default	"UDU USER,1.0"
Remarks	The user defined unit must be set up with this command prior to remote or local selection. There are 5 separate user definable units. The GUI supports all 5 user defined user units, while the basic version only has access to the first one (<i>n</i> = 1)
Example (enhanced)	Cmd Sent: "UDU MYUN, .001" Query reply: "MYUN, 0.001000" (No reply if IEEE-488)
Example (enhanced)	Cmd Sent: "UDU? MYUN, .001" Query reply: "MYUN, 0.001000"
Example (classic)	Sent: "UDU=MYUN, .001" Reply: "MYUN, 0.001000"
Example (classic)	Sent: "UDU2=UN2, .01" Reply: "UN2, 0.010000"
See Also	3.2.10

UL	
Purpose	Read or set an upper limit for the current range.
Command	"UL <i>n</i> "
Query	"UL?"
Classic	"UL= <i>n</i> " "UL"
Arguments	<i>n</i> : The upper limit pressure in the current pressure unit and measurement mode.
Remarks	The PPC4 has an upper limit for each range and for each measurement mode (gauge and absolute). New automated pressure control targets cannot be greater than this value. If the pressure does exceed the upper limit, the pressure display flashes, and pressure control stops. Manual increases in pressure are not allowed as long as the pressure is above the upper limit. Decreases in pressure are allowed. This feature should always be used to prevent accidental over pressure of a device under test.
Example (enhanced)	Cmd sent: "UL 1000" Query reply: "1000.00 kPaa" (No reply if IEEE-488)
Example (enhanced)	Cmd sent: "UL? 1000" Query reply: "1000.00 kPaa"
Example (classic)	Sent: "UL=1000" Reply: "1000.00 kPaa"
Errors	ERR# 6: The argument is out of range.
See Also	"LL" 3.2.21

UNIT	
Purpose	Read or set the pressure unit of measure unit and measurement mode.
Command	<p>"UNIT <i>unit</i> (<i>, ref</i>)"</p> <p>"UNIT <i>unitg</i> (<i>, ref</i>)"</p> <p>"UNIT <i>unita</i> (<i>, ref</i>)"</p>
Query	"UNIT?"
Classic	<p>"UNIT=<i>unit</i> (<i>, ref</i>)"</p> <p>"UNIT=<i>unitg</i> (<i>, ref</i>)"</p> <p>"UNIT=<i>unita</i> (<i>, ref</i>)"</p> <p>"UNIT"</p>
Arguments	<p><i>unit</i>: The text corresponding to the pressure unit of measure.</p> <p><i>ref</i>: The optional unit reference temperature only if the unit is "InWa".</p>
Remarks	<p>This program message determines what unit of measure and what measurement mode is used to display pressure values. Refer to Table 13 for a detailed list of the units available and their labels.</p> <p>The unit text must be followed by 'a' if absolute measurement mode is desired, or gauge mode is assumed. The unit text can optionally be followed by a 'g' to specify gauge measurement mode. There can be a space between the unit text and the 'a' or the 'g'.</p> <p>If a water column unit (inH2O, mH2O, mmH2O) is specified for the pressure unit of measure, an optional second argument "<i>ref</i>" can be set. The "<i>ref</i>" can be 4, 20, or 60 corresponding to InH2O at 4 °C, 20 °C or 60 °F. The reference temperature can also be added directly onto the end of the <i>Unit</i> argument or "@" plus the reference temperature if desired ("inH2O4", "inH2O@4", "inH2O20", "inH2O@20", "inH2O60", or "inH2O@60 corresponding to inH2O at 4 °C, 20 °C or 60 °F). If a temperature reference is not specified, when the unit is "InH2O" or "mmH2O", then the reference temperature is assumed to be 20 °C.</p> <p style="text-align: center;">Note</p> <p style="text-align: center;">The legacy units inWa, mWa and mmWa have been replaced by inH2O, mH2O and mmH2O in the PPC4 and in documentation. The unit command and others such as ARANGE continue to support the former "xxWA" units. The conversion factors are identical.</p> <p>The fifth character of the reply is always 'a' for absolute mode, or 'g' for gauge mode. White spaces proceed this character if needed. The temperature reference is added to the reply only if the unit is "InWa" or "mmWa".</p> <p>"MMODE" must be used to set the measurement mode to negative gauge. The "MODE" command can also be used to set the desired measurement mode only.</p>
Example (enhanced)	<p>Cmd sent: "UNIT kPaa"</p> <p>Query reply: "kPaa"</p> <p>Sent: "UNIT InH2Og, 4"</p> <p>Query reply: "inH2Og, 4"</p> <p>Sent: "UNIT InH2Og60"</p> <p>Query reply: "inH2Og, 60"</p> <p>Sent: "UNIT InH2O@20"</p> <p>Query reply: "inH2Og, 20"</p>
Example (classic)	<p>Sent: "UNIT=kPaa"</p> <p>Reply: "kPaa"</p> <p>Sent: "UNIT=InH2Og, 4"</p> <p>Reply: "inH2Og, 4"</p> <p>Sent: "UNIT=InH2Og@20"</p> <p>Reply: "inH2Og, 20"</p>
Errors	<p>ERR# 7: The <i>unit</i> is invalid.</p> <p>ERR# 6: The <i>ref</i> is invalid.</p> <p>ERR# 20: Absolute measurement mode and altitude units are not allowed with a gauge Q-RPT.</p>
See Also	<p>"MMODE", "MODE"</p> <p>3.2.10, 3.2.11</p>

VAC	
Purpose	Read or set the status of the PPC4 EXHAUST port vacuum or atmosphere monitoring system.
Command	"VAC <i>n</i> "
Query	"VAC?"
Classic	"VAC= <i>n</i> " "VAC"
Default	"VAC 0"
Arguments	<i>n</i> : '0' To disable auto mode and specify that the PPC4 EXHAUST port is open to atmosphere. '1' To disable auto mode and specify that the PPC4 EXHAUST port is connected to a vacuum source. NOTE: Use "AUTOVAC" to enable automated determination of EXHAUST port conditions.
Remarks	The PPC4 has an internal sensor that determines if the EXHAUST port is open to atmosphere or to vacuum. You can manually override it if desired. The query can also be used to see the sensor status (if auto is enabled). If the auto function is disabled, then the query returns the last VAC setting.
Example (enhanced)	Cmd sent: "VAC 1" Query reply: "1" (No reply if IEEE-488)
Example (enhanced)	Cmd sent: "VAC? 1" Query reply: "1"
Example (classic)	Sent: "VAC=1" Query reply: "VAC=1"
Errors	ERR# 6: The argument is not a '0' or a '1'.
See Also	"AUTOVAC" 3.2.27.2

VENT	
Purpose	Read, execute or abort a vent process.
Command	"VENT <i>n</i> "
Query	"VENT?"
Classic	"VENT= <i>n</i> " "VENT"
Arguments	<i>N</i> : '1' to start a vent process. '0' to abort a vent process and close the exhaust valve.
Remarks	The PPC4 vents by setting pressure close to atmospheric and then opening the vent valve. This program message query returns a '0' if the vent valve is closed, or a '1' if the vent valve is open. In gauge measurement modes, a "PS" command of zero is interpreted as a vent command.
Example (enhanced)	Cmd sent: "VENT 1" Query reply: "0" (if not finished venting) (No reply if IEEE-488) "1" (if vented) (No reply if IEEE-488)
Example (enhanced)	Cmd sent: "VENT? 1" Query reply: "0" (if not finished venting) "1" (if vented)
Example (classic)	Sent: "VENT=1" Reply: "VENT=0" (if not finished venting) "VENT=1" (if vented)
Errors	ERR# 6: The argument is not a '0' or a '1'.
See Also	"PS" 3.2.1, 3.2.14

VER	
Purpose	Identify the PPC4, US or SI units, the Q-RPT labels and the software version.
Query	"VER?"
Classic	"VER"
Remarks	The software version of the PPC4 can be read. This is useful for checking for the presence of the PPC4 and for reference purposes. It indicates the internal Q-RPT(s) and software version.
Example (enhanced)	Query sent: "VER?" Query reply: "DH INSTRUMENTS, INC PPC4 us A350K/BG15K Ver1.00 "
Example (classic)	Query sent: "VER" Query reply: "DH INSTRUMENTS, INC PPC4 us A350K/BG15K Ver1.00 "
See Also	None

ZOFFSETn	
Purpose	Read or set the AutoZ pressure offsets (P_{offset}) for the specified or active RPT (preferred method).
Command	"ZOFFSETn <i>GaOffset</i> , <i>AbsOffset</i> "
Query	"ZOFFSETn?"
Classic	"ZOFFSETn= <i>GaOffset</i> , <i>AbsOffset</i> " "ZOFFSETn"
Defaults	"ZOFFSETn = 0.0 Pa, 0.0 Pa" (Gauge Q-RPT) "ZOFFSETn = 101325 Pa, 0.0 Pa" (Absolute Q-RPT)
Optional Suffix	"n" The active RPT is assumed if no suffix is given. '1' Specify the Hi Q-RPT. '2' Specify the Lo Q-RPT
Arguments	<i>GaOffset</i> The RPT pressure offset ("Poffset") for Gauge measurement mode (Pa). <i>AbsOffset</i> : The RPT pressure offset for absolute measurement mode (Pa)
Remarks	The pressure offset (P_{offset}) for the specified internal RPT (IH or IL) or the active Q-RPT can be accessed with this program message. There is a separate offset for gauge and absolute measurement modes, but not all modes apply in all cases. (Gauge RPTs do not support " <i>AbsOffset</i> "). ⚠ Caution <ul style="list-style-type: none"> • Using this program message overwrites the current offset. • Changes made using this program message take effect immediately. If no suffix is given and the active RPT is in an external RPM4, then the P_{offset} for that RPM4's Q-RPT will be accessed.
Example (enhanced)	Cmd sent: "ZOFFSET1 2.1, 0" Query reply: " 2.10 Pa, 0.00 Pa"
Example (classic)	Sent: "ZOFFSET=97293.1, 3.02" Reply: " 97293.10, 3.02"
Errors	ERR# 6: One of the arguments is out of range.
See Also	3.2.22

ZOFFSET:IH and ZOFFSET:IL	
Purpose	Read or set the AutoZ pressure offset (P_{offset}) for the high ("IH") or low ("IL") Q-RPT and current measurement mode. New designs should use the "ZOFFSET <i>n</i> " command.
Command	"ZOFFSET:IH <i>offset</i> " "ZOFFSET:IL <i>offset</i> "
Query	"ZOFFSET:IH?" "ZOFFSET:IL?"
Classic	"ZOFFSET:IH = <i>offset</i> " "ZOFFSET:IL = <i>offset</i> " "ZOFFSET:IH" "ZOFFSET:IL"
Defaults	"ZOFFSET:IH = 0.0" "ZOFFSET:IL = 0.0"
Arguments	<i>Offset</i> : The Q-RPT pressure offset ("Poffset") for the current measurement mode (gauge or absolute) in Pa.
Remarks	The pressure offset (P_{offset}) for the specified Q-RPT (Hi or Lo) in the current measurement mode can be accessed with this program message. External Q-RPTs' P_{offset} cannot be adjusted from PPC4. There is a separate offset for gauge and absolute measurement modes. Using this program message will overwrite the current offset, so caution must be used. Changes made using this program message take effect immediately.
Example (enhanced)	Cmd sent: "ZOFFSET:IL 2.1" Query reply: " 2.10 Pa"
Example (classic)	Sent: "ZOFFSET:IL=2.1" Reply: " 2.10 Pa"
Errors	ERR# 6: One of the arguments is out of range.
See Also	3.2.22

6.6 Status Reporting System

The PPC4 status reporting system is used to track and report system status and errors. It follows the model of the IEEE Std 488.2 and works for the COM1 and the IEEE-488 port with slight differences. The PPC4 can be programmed to respond to various status conditions by asserting the SRQ of the IEEE-488 interface. The COM1 port cannot be supported in such a way, so polling must be used.

6.6.1 Error Queue

The PPC4 keeps track of remote errors by using an error queue. If an error occurs, it is pushed onto the Error Queue. If you are using the COM1 port, the error number is immediately replied in the form "ERR#*nn* where *nn* is the error code from 0 to 99. The "ERR?" (or "ERR") query can then be used to pull the error from the Error Queue in its descriptive text format. If you are using the enhanced program message format, the Error Queue will accumulate errors until full unless they are pulled from the queue. If you are using the classic program format, the Error Queue is cleared every time a new program message is received.

6.6.2 Status Byte Register

The PPC4 contains an 8 bit Status Byte Register that reflects the general status of the PPC4.

Table 23. 8 Bit Status Byte Register

OPER	RQS/MSS	ESB	MAV	N/A	ERROR	N/A	RSR
(128)	(64)	(32)	(16)	(8)	(4)	(2)	(1)

This register is affected by the PPC4 reply output queue, the Error Queue, the Standard Event Status register and the *Ready Event* Status register.

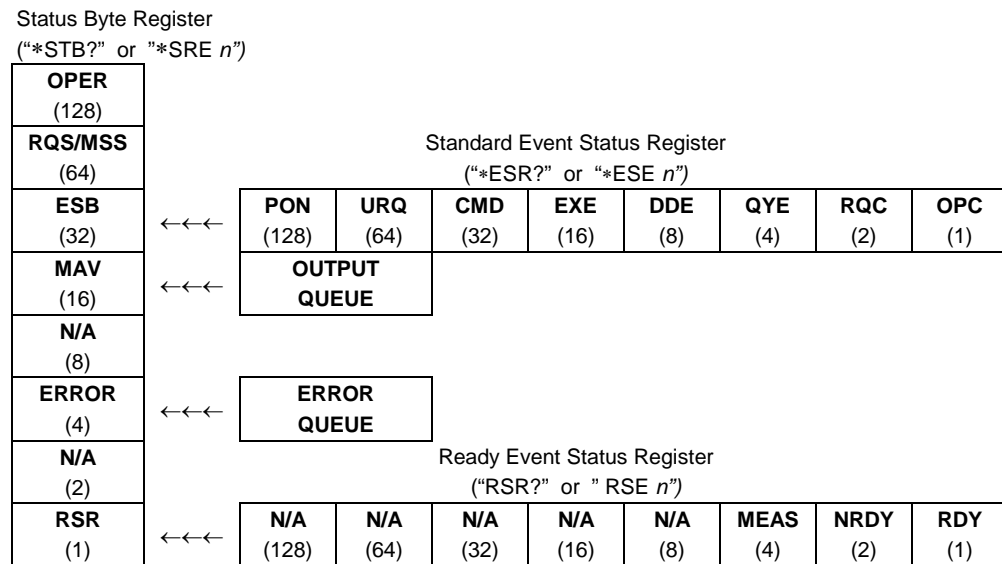

Figure 28. Status Register Schematic

The Status Byte Register can be read using the “****STB?**” query, or by performing a serial poll on the IEEE-488 bus. If you read this using a serial poll then Bit 6 is the RQS. If the “****STB?**” query is used, then bit 6 is the MSS bit. All of the other bits are common to both types of query.

Each of these status bits can cause a SRQ to occur. The Service Request Enable Register (“****SRE**” program message) determines which of these flags are able to assert the SRQ line. This enable register has a matching set of bits that each will enable the designated bit to cause a SRQ, except for the RQS/MSS bit(s) which cannot cause a SRQ. If you set this register to 20 (\$14 hex), an SRQ will occur if the MAV or the ERROR bit are set. The description of these bits are given as:

- OPER** N/A Bit 7 (128)
- RQS** Requested Service Bit 6 (64)
Indicates that the SRQ line of the IEEE-488 interface has been asserted by the PPC4. This bit is cleared when a serial poll is performed on the PPC4, and is a part of the Status Byte Register when read using a serial poll. This bit does not apply if the COM1 port is being used.
- MSS** Master Summary Status Bit 6 (64)
Indicates that an event or events occurred that caused the PPC4 to request service from the Host, much like the RQS bit. Unlike the RQS bit, it is READ ONLY and can be only cleared when the event(s) that caused the service request are cleared.
- ESB** Event Summary Bit 5 (32)
Indicates if an enabled bit in the Standard Event Status Register became set (see Section 4.5.3).
- MAV** Message Available Bit 4 (16)
Indicates that at least one reply message is waiting in the PPC4 IEEE-488 output queue.
- ERROR** Error Queue Not Empty Bit 2 (4)
Indicates that at least one command error message is waiting in the PPC4 IEEE-488 error message queue. Use the “**ERR?**” query to get this message.
- RSR** Ready Summary Bit 0 (1)
Indicates that an enabled bit in the Ready Status Register became set.

6.6.3 Standard Event Register

The PPC4 contains an 8 bit Standard event register that reflects specific PPC4 events. Enabled events in this register will set or clear the ESB bit of the Status Byte Register.

Table 24. 8 Bit Standard Event Register

PON	URQ	CMD	EXE	DDE	QYE	RQC	OPC
(128)	(64)	(32)	(16)	(8)	(4)	(2)	(1)

This register can be read using the “*ESR?” query, Each of these status bits can set the ESB bit of the Status Byte Register, causing a SRQ to occur IF the ESB bit is enabled to do so. The Standard Event Status Enable Register (“*ESE” program message) determines which of these flags are able to assert the ESB bit. The description of these bits are given as:

PON	Power On (Bit 7)
	Indicates that the PPC4 power has been cycled since the last time this bit was read or cleared.
URQ	User Request (Bit 6)
	Indicates that the PPC4 was set to local operation manually from the front panel by the user (pressing the [ESC] key).
CMD	Command Error (Bit 5)
	Indicates that a remote command error has occurred. A command error is typically a syntax error in the use of a correct program message.
EXE	Execution Error (Bit 4)
	Indicates if a remote program message cannot be processed due to device related condition.
DDE	Device Dependent Error (Bit 3)
	Indicates that an internal error has occurred in the PPC4 such as a transducer time-out.
QYE	Query Error (Bit 2)
	Indicates that an error has occurred in the protocol for program message communications. This is typically caused by a program message being sent to the PPC4 without reading a waiting reply.
RQC	Request Control (Bit 1)
	This bit is not supported as the PPC4 cannot become the active controller in charge.
OPC	Operation Complete (Bit 0)
	Indicates that the PPC4 has completed all requested functions.

6.6.4 Ready Status Register

The PPC4 contains an 8 bit Ready Status Register that reflects specific PPC4 measurement and generation ready events (see Section 3.2.3). Enabled events in this register will set or clear the RSB bit of the Status Byte Register.

Table 25. 8 Bit Ready Status Register

N/A	N/A	N/A	N/A	N/A	MEAS	NRDY	RDY
(128)	(64)	(32)	(16)	(8)	(4)	(2)	(1)

This register can be read using the “*RSR?” query, Each of these status bits can set the RSB bit of the Status Byte Register, causing a SRQ to occur IF the RSB bit is enabled to do so. The

Standard Event Status Enable Register (“*RSE” program message) determines which of these flags are able to assert the RSB bit. The description of these bits are given as:

- MEAS** Measurement ready (Bit 2)
Indicates that the PPC4 has completed a Q-RPT measurement.
- NRDY** Generation Not Ready (Bit 1)
Indicates that the PPC4 made a transition from *Ready* to *Not Ready* as defined by the control settings (see Section 3.2.2).
- RDY** Generation Ready (Bit 0)
Indicates that the PPC4 has reached a target pressure and is *Ready* as defined by the control settings (see Section 3.2.2).

6.7 IEEE STD. 488.2 Common And Status Program Messages

The PPC4 supports a set of commands that are common to all instruments conforming to IEEE Std. 488.2. These command make it easy to perform basic function for any device that supports these commands. These commands also cover the status reporting commands. See Section 4.5 for details on the status registers mentioned in these commands.

Table 26. Program Message List

*CLS	Clear all of the status & event structures.
*ESE	Read or set the Standard Event Status Enable Register.
*ESR	Read the Standard Event Status Register.
*IDN	Identify the PPC4 version, range, and serial number.
*OPC	Set the operation complete bit when all operations have completed.
*OPT	Read the list of installed PPC4 options.
*RST	Reset the PPC4 control settings to factory settings.
*TST	Read the power on self test status.
*SRE	Read or set the Service Request Enable Register.
*STB	Read the Status Byte Register.
*RSE	Read or set the Ready Status Enable Register.
*RSR	Read the Ready Status Register.

6.7.1 Program Message Descriptions

*CLS	
Purpose	Clear all of the status & event structures.
Command	"*CLS"
Remarks	This program message clears the following events and status registers: Standard Byte Register (STB) Standard Event Status Register (ESR) Error Queue Pending OPC operations
Example (classic)	Sent: "*CLS" Reply: none

*ESE	
Purpose	Read or set the Standard Event Status Enable Register.
Command	"*ESE <i>n</i> "
Query	"*ESE?"
Default	"*ESE 0"
Arguments	<i>n</i> : '0 to 255' This is the decimal representation of the bit(s) to enable. To enable the PON and QYE bits, the argument would be 128 + 4 = 132.
Remarks	The Standard Event Status Enable register determines which bits in the standard Event Status Register are enabled and included in the Status Byte Register (ESB bit), and can assert the SRQ line. The reply is in decimal numeric form.
Example (enhanced)	Sent: "*ESE=128" (enables the PON bit) Query reply: "128" (no reply if IEEE-488)
Errors	ERR# 6: <i>n</i> is not valid.

*ESR	
Purpose	Read the Standard Event Register.
Command	"*ESR?"
Remarks	The Standard Event Register contents are cleared after reading. The reply is in decimal numeric form.
Example (enhanced)	Sent: "*ESR?" Reply: "20" (the QYE and EXE bits are set)

*IDN	
Purpose	Identify the PPC4 versions, range, and serial number.
Query	"*IDN?"
Remarks	The identification reply is made up of the following comma delimit fields: Manufacturer The product model Serial number of the PPC4 Serial number of the HI pressure RPT Serial number of the LO pressure RPT ('0' if not installed) PPC4 software version. CPU board logic version Main board logic version.
Example (enhanced)	Sent: "*IDN?" Reply: "DH INSTRUMENTS INC, PPC4, 123,100951,63041, Ver1.00E, 1.00a,1.00a"

*OPC	
Purpose	Sets the operation complete bit when all operations have completed.
Command	"*OPC"
Query	"*OPC?"
Remarks	This Command enables the PPC4 to set the OPC bit in the Standard Event Status Register when it has completed all pending functions. The Query replies with a "1" when all functions are complete.
Example (enhanced)	Sent: "*OPC" Query reply: "1"

*OPT	
Purpose	Reads the list of installed PPC4 options.
Query	"*OPT?"
Remarks	This Query returns any registered option(s) installed in the PPC4. Each option is separated by a comma. If there are no options installed, the reply will be "NONE" Possible options: "IEEE-488:0" The IEEE-488 option is installed. "USB" The rear panel USB port is installed "ETHERNET" The rear panel Ethernet option is installed "GUI" Indicates PPC4-gui with an LCD
Example (enhanced)	Sent: "*OPT?" Reply: "IEEE-488:0, USB, ETHERNET" Reply: "NONE" (no options installed)

*RST	
Purpose	Resets the PPC4 control settings to factory settings.
Command	"*RST"
Remarks	This Command sets the PPC4 settings to factory settings. This equivalent to a front panel executed RESET/SET. This does not affect the communications settings.
Example (enhanced)	Sent: "*RST" Reply: "*RST" (no reply if IEEE-488)
See Also	Section 3.5.4.1, <u>Reset - Sets</u>

*SRE	
Purpose	Read or set the Service Request Enable Register.
Command	"*SRE <i>n</i> "
Query	"*SRE?"
Default	"*SRE 0"
Arguments	<i>n</i> : '0 to 255' This is the decimal representation of the bit(s) to enable. To allow the MAV and ESB bits to assert the SRQ line, the argument would be 32 + 16 = 48. Bit 6 (64) is reserved and cannot be set.
Remarks	The Service Request Enable Register determines which bits of the Status Byte can set the MSS bit of the Status Byte and request service by asserting the SRQ line of the IEEE-488 interface.
Example (enhanced)	Sent: "*SRE=48" (enables the MAV and ESB bits) Query reply: "48" (no reply if IEEE-488)
Errors	ERR# 6: <i>n</i> is not valid.

*STB	
Purpose	Read the Status Byte Register.
Command	"*STB?"
Remarks	The Status Byte Register reflects the general status of the PPC4. The 'MSS' bit state is represented by bit 6.
Example (enhanced)	Sent: "*STB?" Reply: "80" (The MSS and MAV bits are set)

*TST	
Purpose	Read the power on self test status.
Query	"*TST?"
Remarks	The PPC4 system memory stores the user settings (units, resolution, generation settings) and retains them when the unit is OFF. On power-up, this memory is checked. If this memory is corrupted, all user settings are reset to default (as if the "*RST" program message was executed), and the *TST query will return a non zero value. If the PPC4 passed the test on power-up OR if the *TST query was used at least once since the PPC4 was powered up the reply will be a '0'.
Example (enhanced)	Sent: "*RST?" Reply: "1"

*RSE	
Purpose	Read or set the Ready Status Enable Register.
Command	"RSE <i>n</i> "
Query	"RSE?"
Default	"RSE 0"
Arguments	<i>n</i> : '0 to 255' This is the decimal representation of the bit(s) to enable. To enable the RDY bit, the argument would be 1.
Remarks	The Ready Status Enable Register determines which bits in the Ready Status Register are enabled and included in the Status Byte Register (RSR bit), and can assert the SRQ line. The reply is in decimal numeric form.
Example (enhanced)	Sent: "*RSE=1" (enables the RDY bit) Query reply: "1" (no reply if IEEE-488)
Errors	ERR# 6: <i>n</i> is not valid.

*RSR	
Purpose	Read the Ready Status Register.
Command	"RSR?"
Remarks	The Ready Status Register contents are cleared after reading. The reply is in decimal numeric form.
Example (enhanced)	Sent: "RSR?" Reply: "6" (The MEAS and NRDY)

Notes:



7. Maintenance, Adjustments and Calibration

7.1 Overview

PPC4 was designed for maintenance free operation. No maintenance is required other than:

- Regular rezeroing of quartz reference pressure transducers (Q-RPT), if present (see 3.2.22).
- Periodic calibration of Q-RPTs, if present (see Section 7.2).
- Adjustment of the on-board barometer and/or utility sensor, if present (see Sections 7.3, 7.4).
- Automated adjustment of pressure controlling parameters, as needed (see Section 3.2.13).

This section provides information on maintenance, adjustment and calibration procedures, and recommended overhaul procedures.

Caution

PPC4 is a sophisticated pressure setting and measuring instrument with advanced on-board features and functions. Before assuming that unexpected behavior is caused by a system defect or breakdown, use this manual and other training facilities to become thoroughly familiar with PPC4 operation. For rapid assistance in specific situations use the troubleshooting guide in Section 8.

Note

PPC4 is covered by a limited one (1) year warranty. Unauthorized service or repair during the warranty period is undertaken at the owner's risk and may cause damage that is not covered under warranty and/or may void the warranty.

7.2 Calibration of Quartz Reference Pressure Transducers (Q-RPTs)

7.2.1 Principle

PPC4 may be equipped with one or two quartz reference pressure transducers (Q-RPTs) that are the source of low uncertainty pressure measurement for the system.

To calibrate a Q-RPT, pressures from a reference are applied to the Q-RPT at ascending and descending points over the range. The recommended pressure sequence for a calibration varies depending on whether the Q-RPT is of Premium, Standard or Full Scale Standard class (see Section 1.2.2.1). The pressure defined by the reference and the corresponding Q-RPT readings are recorded at each point. After all of the pressures have been applied and recorded, adjustments are made to fit the Q-RPT pressure readings to the reference. Fitting the readings means performing a linear regression to arrive at the lowest value of the residuals of errors of the Q-RPT relative to the reference. The Q-RPT output is adjusted by user settable coefficients: PA (an adder or offset) and PM (a multiplier or span adjustment) (see Section 7.2.1.1).

The calibration process is performed independently on each Q-RPT to arrive at its optimal fit.

When running calibrations, collecting as received data and calculating PA and PM adjustments, whether AutoZ is normally used, whether it is ON or OFF and what the value of Zoffset is should be considered (Section 3.2.22).

Note

CalTool for RPTs software provided with the PPC4 supports the calibration process of PPC4 Q-RPTs. CalTool and its documentation are provided on a General Accessories Disk with the new PPC4. Most users should use CalTool software to assist in the calibration of PPC4.

PPC4 is delivered with an interactive Q-RPT calibration utility that steps the operator through the complete Q-RPT calibration procedure including applying the necessary pressures, collecting data automatically, calculating new PA and PM values, previewing the results of the new calibration and activating the results of the new calibration (see the CalTool for RPTs manual on the General Accessories Disk). PPC4 also provides complete front panel and remote access to Q-RPT calibration parameters so that Q-RPT calibrations can be performed without using CalTool software (see Section 7.2.8).

Note

PPC4 may also use external Q-RPTs mounted in RPM4 Reference Pressure Monitors. RPM4 Q-RPTs are calibrated independently of PPC4 (see the RPM4 Operation and Maintenance Manual).

7.2.1.1 PA and PM Coefficients

The coefficients used to adjust Q-RPT readings are designated PA (an adder or offset) and PM (a multiplier or span set). The coefficients affect the Q-RPT reading following:

$$\text{Corrected reading} = (\text{Uncorrected reading} \cdot \text{PM}) + \text{PA}$$

PA is expressed in units of pressure (always the SI unit, Pascal).

PM is dimensionless.

Each Q-RPT has its own unique PA and PM values. The PA and PM values currently in use can be viewed and edited in the CAL function (see Section 6.5.4). PA and PM values are automatically edited when CalTool software is used and the results are activated.

Caution

As editing PA and PM values will change Q-RPT calibration, they should only be edited by qualified personnel as part of the calibration process. Caution should be taken to avoid accidental editing and a security system is available to prevent access (see Section 3.2.26.5). Incorrect editing of PA and PM values can cause out of tolerance measurements.

Note

A new PPC4 is delivered with PA and PM values set to zero and 1 for all Q-RPTs. This does not mean that the PPC4 has not been calibrated. In the original factory calibration, privileged factory coefficients are used for calibration with the user PA and PM set to zero and 1.

7.2.1.2 As Received and As Left Data

Frequently, calibration procedures require that as received and as left data be reported. The necessary information to report as received and as left data on the calibration of PPC4 Q-RPTs can be obtained in several ways.

When the PPC4 CalTool calibration assistance software is used, as received data is displayed while running the calibration and is automatically recorded and provided if desired. As left data is also calculated and presented.

At any time, a) reference pressures applied, b) associated transducer readings, c) PA and PM and P_{offset} values can be used to calculate as received and as left values. For example, backing out PA and PM on the as left data yields the transducer readings with PA = 0 and PM = 1. Then applying the as received PA and PM and P_{offset} values to the readings calculates *as received* readings (the readings that the transducer would have made with the old PA, PM and P_{offset}).

- **It is recommended that “as received” values of PA, PM and P_{offset} (for absolute mode calibrations if AutoZero is used in normal operation) be recorded for each Q-RPT prior to running the calibration.**

7.2.1.2.1 Basic Interface

The current PA and PM and absolute mode P_{offset} can be viewed by using **<Spec>**, **<Cal>**, **<Hi RPT/Lo RPT/Barometer>**, **<View>** from the Main Menu. The current value of gauge mode P_{offset} can be viewed by using **<Spec>**, **<AutoZ>**, **<View>** from the Main Menu.

7.2.1.2.2 Advanced Interface

The current PA, PM and P_{offset} values can be viewed by using **[Settings]**, **<More >>>**, **<Calibration>**. From this screen either the Hi RPT, Lo RPT or Barometer may be viewed.

For both Hi and Lo RPT, using **<Calibration>** displays Cal Date, PA and PM. For Hi and Lo RPT, using **<AutoZ>** displays the values for Gauge P_{offset} and, if the Q-RPT is absolute, Absolute P_{offset} as well.

Using **Barometer** shows the Barometer screen, displaying Cal Date, PA, PM and the current Barometer reading.

Note

If the security level is set to Low or High viewing the calibration coefficients is allowed but no changes are accepted. A warning is displayed when entering and exiting secure screens.

7.2.2 Equipment Required

Note

The recommended calibration standards for PPC4 Q-RPTs are DHI PG7000 gas operated piston gauges (PG7201, PG7202, PG7601). Contact DHI for additional information.

Gas operated piston gauge (deadweight tester), with the following characteristics:

- **Measurement uncertainty of ± 0.0025 % of reading for Standard or Full Scale Standard Class Q-RPTs or ± 0.002 % of reading for Premium Class Q-RPTs. A**

reference with greater measurement uncertainty may be used but PPC4 measurement uncertainty may be degraded proportionally from published specifications.

- **If the Q-RPT is an Axxx (absolute) type and will be used in the absolute and/or negative gauge measurement modes, the reference must be able to apply absolute pressures:** Absolute pressures may be achieved either by operation relative to an evacuated bell jar or, for higher pressures, by addition of atmospheric pressure measured by a high accuracy barometer. **Axxx (absolute) Q-RPTs that will not be used in absolute or negative gauge measurement modes (as is very often the case for higher pressure Q-RPTs) do not require the application of absolute pressure for calibration and may be calibrated using a gauge pressure reference.**

Caution

Axxx (absolute) Q-RPTs calibrated in gauge measurement mode by applying gauge reference pressure values should be used in gauge mode only (see Sections 3.2.11, 7.2.5).

- **Able to supply the recommended sequence of pressure points in the range to be calibrated:** See Section 7.2.4 for information on the recommended calibration point sequence for various Q-RPT types and classes.

7.2.3 Set-up and Preparation

To set-up and prepare the PPC4 for calibration of an internal Q-RPT:

- ❶ Set the PPC4 on a stable surface near the calibration standard at a height as close as possible to the calibration standard's reference height. Consider the connections that may need to be made to the rear panel and access to the front panel display and keypad.
- ❷ Connect a pressure supply greater than the maximum pressure to be applied during the calibration to the PPC4 rear panel **SUPPLY** port (1/8 in. NPT F). (See Section 2.3.4)
- ❸ If the calibration will include pressures under atmospheric pressure, connect a vacuum pump to the PPC4 rear panel **EXHAUST** port (1/4 in. NPT F). There will be a constant bleed of gas through the **EXHAUST** port so the vacuum pump should be self-venting or disconnected when OFF (see Section 2.3.5).
- ❹ Connect the calibration standard output to the PPC4 rear panel **TEST(+)** port (1/8 in. NPT F).

Caution

DO NOT apply pressure to the TEST(+) port without having a pressure supply greater than the applied pressure connected to the SUPPLY port. Do not cause sudden external pressure changes. Damage to internal PPC4 components could result. Unless the piston gauge used to calibrate the PPC4 has automated pressure control, it is highly recommended that the PPC4 direct pressure control keys (see Section 3.2.1) be used to slew and adjust pressure during the calibration. This will minimize the risk of accidental overpressure of the PPC4 Q-RPTs.

7.2.4 Recommended Calibration Point Sequence

Calibration adjustments to PPC4 Q-RPTs are made by adjusting calibration coefficients, PA and PM (see Section 7.2.1.1). To adjust these coefficients to optimum values giving the best results over the Q-RPTs complete operating range, specific calibration point sequences are recommended. The recommended point sequence depends upon whether the Q-RPT being calibrated is a Premium, Standard or Full Scale Standard Class (see Section 1.2.2.1). The class of the PPC4 Q-RPTs is indicated on the model number on the product label and on the rear panel Q-RPT model (<p> for premium, <s> for standard and <f> for full scale standard - for example A7Ms or A7Mp).

Prior to running the calibration point sequence, the Q-RPT should be exercised by:

- a) Setting full scale pressure.
- b) Dwelling at full scale pressure for 5 minutes.
- c) Returning to atmospheric pressure (vented). If the Q-RPT is a gas operated Axxx type, use vacuum rather than atmospheric pressure.
- d) Dwelling for twenty minutes.

A dwell time after setting the pressure of at least 60 seconds before taking data at each point is recommended.

Section 7.2.4.1 gives calibration point sequences for Standard and Full Scale Standard Class Q-RPTs and Section 7.2.4.2 gives calibration point sequences for Premium Q-RPTs.

Note

It is not required that the calibration pressure standard apply precisely the nominal pressure value of each calibration point as long as the exact value of the applied pressure is known. Best results are obtained if the actual applied pressure is within 2 % of the nominal point definition.

7.2.4.1 Standard and Full Scale Standard Class Q-RPTs

See additional information in Section 7.2.4 concerning exercising the Q-RPT and dwell time at pressure points.

Table 27. Calibration Point Sequence, Standard Class, Axxx and Gxxx Q-RPTs

CALIBRATION SEGMENT	POINT NO.	POINT [% OF SPAN]
Ascending	1	Lowest Pressure ¹
	2	25 %
	3	50 %
	4	75 %
	5	100 %
Descending	6	75 %
	7	50 %
	8	25 %
	9	Lowest Pressure ¹

¹ In absolute mode, the lowest point that can be set reliably by the reference piston gauge. Zero (vented) in gauge mode.

Note

Axxx (absolute) Q-RPTs that will NOT be used in absolute or negative gauge measurement modes may be calibrated in gauge measurement mode with a gauge pressure standard. Axxx (absolute) Q-RPTs calibrated in gauge measurement mode by applying gauge reference pressure values should be used in gauge mode only (see Section 7.2.5).

Table 28. Calibration Point Sequence, Standard Class, BGxxx Q-RPTs

CALIBRATION SEGMENT	POINT NO.	POINT [% OF SPAN] ¹
Ascending	1	0 %
	2	25 %
	3	50 %
	4	75 %
	5	100 %
Descending	6	75 %
	7	50 %
	8	25 %
	9	0 %

1. The BG15K span is – 15 to + 15 kPa, 30 kPa total. Therefore, 0 % is – 15 kPa, 25 % is – 7.5 kPa, 100 % is + 15 kPa, etc.

Note

BGxxx (bi-directional gauge) Q-RPTs that will NOT be used in negative gauge measurement mode may be calibrated in gauge (positive pressures) measurement mode only. Use the gauge mode (Gxxx) calibration point sequence (see Table 27). BGxxx Q-RPTs calibrated in gauge measurement mode only should not be used in negative gauge mode.

Table 29. Calibration Point Sequence, Standard Class, BA100K Q-RPT

CALIBRATION SEGMENT	POINT NO.	POINT [% OF SPAN] ¹
Ascending	1	0 %
	2	25 %
	3	50 %
	4	75 %
	5	100 %
Descending	6	75 %
	7	50 %
	8	25 %
	9	0 %

1. The BA100K span is 70 to 110 kPa absolute.

7.2.4.2 Premium Class Q-RPTs

See additional information in Section 7.2.4 concerning exercising the Q-RPT and dwell time at pressure points.

Verification of Premium Class Q-RPTs

When verifying (as opposed to calibrating) a Premium Q-RPT it is not necessary to include the higher density of points that is recommended for determination of the calibration coefficients. A standard ascending/descending 9 or 11 point run is adequate. To verify that the uncertainty turndown with AutoRange is in tolerance (see Sections 3.2.6, 1.2.2.1), it is recommended that the verification of a Premium Q-RPT include a verification of an AutoRanged span of 30 % of the maximum Q-RPT span. For example, verify an A7M Q-RPT in the default range of 0 to 7 MPa (1 000 psi) and in the AutoRange range of 2.1 MPa (300 psi).

Table 30. Calibration Point Sequence, Premium Class, Axxx and Gxxx Q-RPTs

CALIBRATION SEGMENT	POINT NO.	POINT [% OF SPAN] ¹
Ascending	1	Lowest Pressure ¹
	2	5 %
	3	10 %
	4	15 %
	5	20 %
	6	30 %
	7	40 %
	8	50 %
	9	60 %
	10	80 %
	11	100 %
Descending	12	80 %
	13	50 %
	14	20 %
	15	Lowest Pressure ¹

¹ In absolute mode, lowest point that can be set reliably by the reference piston gauge. Zero (vented) in gauge mode.

Note

Axxx (absolute) Q-RPTs that will NOT be used in absolute or negative gauge measurement modes may be calibrated in gauge measurement mode with a gauge pressure standard. Axxx (absolute) Q-RPTs calibrated in gauge measurement mode by applying gauge reference pressure values should be used in gauge mode only (see Section 7.2.5).

Table 31. Calibration Point Sequence, Premium Class, BGxxx Q-RPTs

CALIBRATION SEGMENT	POINT NO.	POINT [% OF SPAN] ¹
Ascending	1	0 %
	2	15 %
	3	30 %
	4	40 %
	5	45 %
	6	50 %
	7	55 %
	8	60 %
	9	70 %
	10	85 %
	11	100 %
Descending	12	70 %
	13	50 %
	14	30 %
	15	0 %

¹ The BG15K span is – 15 to + 15 kPa, 30 kPa total. Therefore, 0 % is – 15 kPa, 25 % is – 7.5 kPa, 100 % is + 15 kPa, etc.

Note

BGxxx (bi-directional gauge) Q-RPTs that will not be used in negative gauge measurement mode may be calibrated in gauge (positive pressures) measurement mode only. Use the gauge mode (Gxxx) calibration point sequence (see Table 30). BGxxx Q-RPTs calibrated in gauge measurement mode only should not be used in negative gauge mode.

7.2.5 Turning Off Absolute and Negative Gauge Measurement Modes for Axxx (Absolute) Q-RPTs

○ PURPOSE

To prevent operation in absolute and negative gauge measurement modes with an Axxx (absolute) Q-RPT.

○ PRINCIPLE

Axxx (absolute) Q-RPTs are frequently used in gauge measurement mode only (see Section 3.2.11). Axxx Q-RPTs that are used in gauge mode only, may be calibrated in gauge mode with a reference that applies gauge pressures. Calibration with an absolute reference is not necessary. However, if an Axxx Q-RPT is calibrated in gauge mode, it is not possible to know if it is in or out of tolerance in absolute and negative gauge modes. To avoid using absolute and negative gauge measurement modes on an Axxx Q-RPT that is calibrated for gauge mode only, access to absolute and negative gauge modes can be turned ON and OFF.

○ OPERATION

Note

See Section 7.2.7 for more detailed information on editing and viewing Q-RPT calibration information.

⚠ Caution

As editing PA and PM values will change the calibration of the Q-RPTs, the edit function should only be used by qualified personnel as part of the calibration process. Caution should be taken to avoid accidental editing. A user level security system is available to control access (see Section 3.2.26.5).

7.2.5.1 Basic Interface

Turning absolute and negative gauge mode operation ON and OFF for a Q-RPT occurs in the same area in which calibration coefficients is edited. To access the Q-RPT calibration editing area use **<Spec>**, **<Cal>** and select the desired Q-RPT. Then **<Edit>** to make changes.

ENTER through the calibration information. After viewing the values of PA and PM the display is:

```
Absolute and
neg g mode: ♦Off ♦On
```

The cursor is on the number corresponding to the current selection. Make the desired selection. **<On>** causes absolute and negative gauge modes to be unavailable for the Q-RPT.

7.2.5.2 Advanced Interface

The Gauge Only setting is located in the **[Settings]**, **<More >>>**, **<Calibration>**, **<Hi RPT>** or **<Lo RPT>**, **<Calibration>** screen. If security is **Off** (see Section 3.2.26.5) **Gauge only** can be changed. Setting **Gauge Only** to **On** causes absolute and negative gauge modes to be unavailable for the Q-RPT.

[OK] to accept change and exit to Main Run Screen, **[Back]** to return to **<Calibration>** without making changes, **[Esc]** or **ESC** to exit to the Main Run Screen without making changes.

Note

PPC4 may also use external Q-RPTs mounted in RPM4 Reference Pressure Monitors. Viewing and adjustment of RPM4 calibration information is performed locally on the RPM4, not through PPC4 (see the RPM4 Operation and Maintenance Manual).

7.2.6 Q-RPT Calibration Using CalTool for RPTs Software

To calibrate PPC4 Q-RPTs using CalTool software, refer to Sections 7.2.1, 7.2.2 and 7.2.3 in this manual and then refer to the CalTool for RPTs Software Manual.

CalTool for RPTs software and manual are supplied on the PPC4 General Accessories Disk (white CD) and can be downloaded from www.dhstruments.com.

7.2.7 Editing and Viewing Q-RPT Calibration Information

○ PURPOSE

View and/or edit Q-RPT calibration information fields including:

- **The calibration date** – This field is normally used to record the date on which the Q-RPT is calibrated.
- **The value of absolute mode AutoZero P_{offset} (Axxx Q-RPTs only)** – See Section 3.2.22 for complete AutoZero information. This value is normally set to zero following absolute measurement mode calibration of an Axxx Q-RPT.
- **The value of PA** – The pressure adder for the selected Q-RPT (see 7.2.1.1).
- **The value of PM** – The pressure multiplier for the selected Q-RPT (see 7.2.1.1).
- **Absolute and negative gauge measurement modes ON or OFF (Axxx Q-RPTs only)** – See Section 3.2.11 for complete information on measurement modes. This is set to OFF if the Axxx Q-RPT was calibrated in gauge mode with a gauge pressure standard (see Section 7.2.5).

○ OPERATION

Caution

As editing PA and PM values will change the calibration of the Q-RPTs, the edit function should only be used by qualified personnel as part of the calibration process. Caution should be taken to avoid accidental editing. A user level security system is available to control access (see Section 3.2.26.5).

Note

- A new PPC4 is delivered with PA and PM values set to zero and 1 for all ranges. This does not mean that the PPC4 has not been calibrated. In the original factory calibration, privileged factory coefficients are used for calibration with the user PA and PM set to zero and 1.
- PA is always in units of Pascal (Pa). PM is dimensionless.
- PPC4 may also use external Q-RPTs mounted in RPM4 Reference Pressure Monitors. Viewing and adjustment of RPM4 calibration information is performed locally on the RPM4, not through PPC4 (see the RPM4 Operation and Maintenance Manual).

7.2.7.1 Basic Interface

To access Q-RPT calibration information viewing or editing press **<Spec>**, **<Cal>**. Select the desired Q-RPT. **<View>** displays the calibration information fields. **<Edit>** displays the fields and allows them to be edited. The display is:

1. Date of last calibration in YYYYMMDD format.
2. Position designator of the Q-RPT being viewed.
3. Current value of absolute mode P_{offset} . This line is blank if the Q-RPT is not an Axxx type

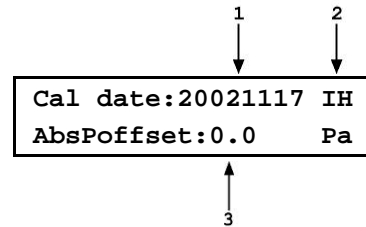

If in **edit** mode, the calibration information fields can be edited. Edits to P_{offset} are common with changes made in the AutoZ edit or run function (see Section 3.2.22). **ENTER** on the last field continues to the next view/edit screen:

1. Value of PA.
2. Position designator of the Q-RPT being viewed.
3. Value of PM.

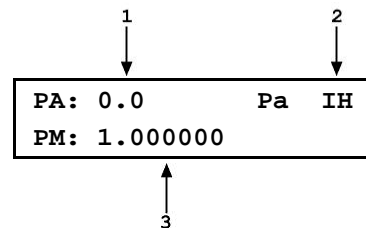

If in **edit** mode, the calibration fields can be edited. If the selected Q-RPT is an Axxx Q-RPT, pressing **ENTER** in the **PM** field continues to the next calibration information display (this display is skipped if the Q-RPT is an Gxxx or BGxxx):

1. Position designator of the Q-RPT being viewed.
2. Cursor is on current ON or OFF selection.

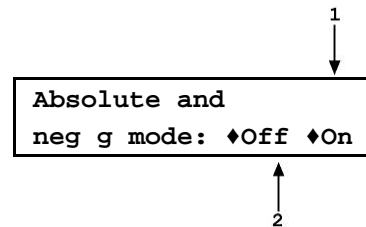

If in **edit** mode, the OFF or ON status can be changed by selecting **<Off>** or **<On>** (see Section 7.2.5). **ENTER** in view mode returns to the view/edit screen. **ENTER** in edit mode goes to confirmation of change activation if changes have been made. **ESC** from any edit screen exits the edit screen without activating any changes.

7.2.7.2 Advanced Interface

To access the Calibration Coefficients use **[Settings]**, **<More >>>**, **<Calibration>**.

Hi or Lo RPT PA, PM and Cal Date can be viewed and edited by using **[Settings]**, **<More >>>**, **<Calibration>**, **<Hi RPT>** or **<Lo RPT>**, **<Calibration>**.

Cal Date: Enter the Cal Date in year/month/day format (yyyymmdd)

PA: Enter PA in units of Pa

PM: Enter PM (dimensionless)

Gauge Only: **On** to prevent Absolute or Negative Gauge modes with an Absolute Q-RPT (see Section 7.2.5).

To view and edit the Poffset values for the Hi or Lo RPT use **[Settings]**, **<More >>>**, **<Calibration>**, **<Hi RPT>** or **<Lo RPT>**, **<AutoZ>** (See Section 5.7.5.1).

Absolute AutoZ: On to turn AutoZ On, Off to turn Absolute AutoZ Off

Absolute Poffset: Value of Poffset (AutoZ offset) in Absolute mode

Gauge AutoZ: On to turn Gauge AutoZ On, Off to turn Gauge AutoZ Off

Gauge Poffset: Value of Poffset (AutoZ offset) in Gauge mode

[OK] to accept changes and return to the Main Run Screen. **[Back]** to return to **<Calibration>** and make no changes. **[Esc]** or **ESC** to exit to the Main Run Screen and make no changes.

7.2.7.3 Q- RPT Uncertainty

○ PURPOSE

Configure and edit the settings for calculation and display of Q-RPT live uncertainty (see Section 3.2.29).

○ OPERATION

The Uncertainty functions are located in **[Settings]**, **<More >>>**, **<Calibration>**, **<Hi RPT>** or **<Lo RPT>**, **<Uncertainty1>** or **<Uncertainty2>**.

7.2.7.3.1 Uncertainty1

This screen controls display and type of uncertainty as well as uncertainty in head height.

Display: **On** to enable display of live uncertainty in Main Run Screen, **Off** to disable display of uncertainty.

Type: **Measured** or **Delivered** (including control components)

Head Height: Uncertainty in head height (same units as Head)

[OK] to accept changes and return to the Main Run Screen. **[Back]** to return to **<Calibration>** and make no changes. **[Esc]** or **ESC** to exit to the Main Run Screen and make no changes.

7.2.7.3.2 Uncertainty2

This screen accesses values for uncertainty calculation components (see Sections 3.2.29.1 and 3.2.29.3).

%Reading: Relative uncertainty (% of Reading)

%Span: Threshold uncertainty (% of AutoRange Span)

Scaling: Scaling factor

%Max Span, AutoZ on: Zero stability with AutoZ on (% of Q-RPT span)

%Max Span, AutoZ off: Zero stability with AutoZ off (% of Q-RPT span)

[OK] to accept changes and return to the Main Run Screen. **[Back]** to return to **<Calibration>** and make no changes. **[Esc]** or **ESC** to exit to the Main Run Screen and make no changes.

7.2.8 Q-RPT Calibration/Adjustment without CalTool for RPTs Software

○ PRINCIPLE

The PPC4 Q-RPTs can be calibrated and adjustments made without using CalTool for RPTs software. This requires:

- Applying pressures with a calibration standard and recording the pressures measured by PPC4.
- Calculating new PA and PM values and entering them.
- Setting P_{offset} to zero for Axxx Q-RPTs.

⚠ Caution

Before proceeding to calibrate a reference pressure transducer without using CalTool for RPTs software, Sections 7.2.1, 7.2.2 and 7.2.3, Calibration of Reference Pressure Transducers, Equipment Required, Setup and Preparation should be reviewed thoroughly.

7.2.8.1 Basic Interface Operation

The typical procedure for calibrating a Q-RPT in a PPC4 with Basic User Interface is:

- ❶ Set-up and prepare the PPC4 for calibration (see Sections 7.2.2 and 7.2.3).
- ❷ Select **<RPT>** from the Main Menu to choose the Q-RPT to be calibrated (see Section 3.2.5). Be sure to set the DF range (not an AutoRanged range).
- ❸ Select **<Head>** from the Main Menu to set the HEAD to zero (see Section 3.2.16). Select **<Unit>** from the Main Menu to set the desired pressure unit of measure (see Section 3.2.10). Select **<Mode>** from the Main Menu to set the desired pressure measurement mode (see Section 3.2.11). Axxx (absolute) Q-RPTs that will be used in gauge measurement mode only, may be calibrated in gauge measurement mode with a gauge pressure standard (see Section 7.2.5).
- ❹ Select **<Spec>**, **<AutoZ>** from the Main Menu to access the AutoZ function (see Section 3.2.22).

If calibrating in absolute measurement mode, turn AutoZ ON if it is left ON in normal PPC4 operation. If calibrating in gauge measurement mode, always turn AutoZ ON.

- ❺ Select **<Spec>**, **<Cal>**, **<Hi RPT>** or **<Lo RPT>**, **<View>**, read and record the current values of PA and PM for the Q-RPT to be calibrated. If calibrating in absolute mode, also record the value of P_{offset} .
- ❻ Run the recommended calibration point sequence for the Q-RPT (see Section 7.2.4) recording the pressure applied by the standard and the PPC4 reading at each calibration point. Dwell at least 90 seconds at each point after setting the reference pressure to allow full stabilization before taking data. The data recorded is the “as received” data for this calibration.
- ❼ Enter the calibration pressures and PPC4 readings into a spreadsheet. Calculate the “non-corrected” PPC4 readings by backing out the PA, PM and P_{offset} (P_{offset} only in the case of Axxx (absolute) Q-RPTs in absolute mode) recorded in Step ❺ above, following:

$$\text{non-corrected reading} = ((\text{corrected reading} - \text{PA})/\text{PM}) + P_{\text{offset}}$$

- ⑧ Perform a linear regression to find the offset and slope that best fit the non-corrected PPC4 readings to the calibration standard pressures. The offset is the new value of PA, the slope is the new value of PM.
- ⑨ Select <Spec>, <Cal>, <Hi RPT> or <Lo RPT>, <edit> and enter the new calibration date and the new values of PA and PM for the Q-RPT and range calibrated. If this is an Axxx Q-RPT used in absolute mode, edit the value of P_{offset} to zero. If this is an Axxx Q-RPT and the calibration was performed in gauge mode, turn absolute and negative gauge modes OFF to avoid their being used after the calibration (see Section 7.2.5).
- ⑩ Calculate as left data for the calibration if desired following:
as left reading = (non-corrected reading • new PM) + new PA
- ⑪ Perform additional verification pressure runs as desired.

7.2.8.2 Advanced Interface Operation

The typical procedure for calibrating a Q-RPT in a PPC4-ui (with Advanced User Interface) is:

- ① Set-up and prepare the PPC4 for calibration (see Sections 7.2.2 and 7.2.3).
- ② Activate the Q-RPT to be calibrated using [AutoRange], Range to choose the Default Range of the Q-RPT (see Section 3.2.5). Be sure to set the DF range (not an AutoRanged range).
- ③ Set the Head to zero using [Settings], <Pressure>, Head (see Section 3.2.16). Set the desired pressure unit of measure using [Settings], <Pressure>, Pressure Unit (see Section 3.2.10). Set the desired pressure measurement mode using [Settings], <Pressure>, Measurement Mode (see Section 3.2.11). Axxx (absolute) Q-RPTs that will be used in gauge measurement mode only, may be calibrated in gauge measurement mode with a gauge pressure standard (see Section 7.2.5).
- ④ Check the AutoZ function using the AutoZ shortcut (see Section 3.2.22).
 If calibrating in absolute measurement mode, turn AutoZ ON if it is left ON in normal PPC4 operation. If calibrating in gauge measurement mode, always turn AutoZ ON.
- ⑤ Use [Settings], <Calibration>, Hi RPT or Lo RPT, read and record the current values of PA and PM for the Q-RPT to be calibrated. If calibrating in absolute mode, also record the value of P_{offset} from [Settings], <Calibration>, <AutoZ>, Absolute Poffset..
- ⑥ Run the recommended calibration point sequence for the Q-RPT (see Section 7.2.4) recording the pressure applied by the standard and the PPC4 reading at each calibration point. Dwell at least 90 seconds at each point after setting the reference pressure to allow full stabilization before taking data. The data recorded is the “as received” data for this calibration.
- ⑦ Enter the calibration pressures and PPC4 readings into a spreadsheet. Calculate the “non-corrected” PPC4 readings by backing out the PA, PM and P_{offset} (P_{offset} only in the case of Axxx (absolute) Q-RPTs in absolute mode) recorded in Step ⑤ above, following:
non-corrected reading = ((corrected reading - PA)/PM) + P_{offset}
- ⑧ Perform a linear regression to find the offset and slope that best fit the non-corrected PPC4 readings to the calibration standard pressures. The offset is the new value of PA, the slope is the new value of PM.

- ⑨ Use **[Settings]**, **<Calibration>**, **Hi RPT** or **Lo RPT** and write the new calibration date and the new values of PA and PM for the Q-RPT and range calibrated. If this is an Axxx Q-RPT used in absolute mode, use **[Settings]**, **<Calibration>**, **<AutoZ>**, **Absolute Poffset** to edit the value of P_{offset} to zero. If this is an Axxx Q-RPT and the calibration was performed in gauge mode, turn absolute and negative gauge modes Off to avoid their being used after the calibration by setting **Gauge Only** to **On** (see Section 7.2.5).
- ⑩ Calculate as left data for the calibration if desired following:
as left reading = (non-corrected reading • new PM) + new PA
- ⑪ Perform additional verification pressure runs as desired.

7.3 Adjustment of an On-board Barometer

○ PURPOSE

To adjust the output of the on-board barometer (see Sections 1.2.2.3 and 3.2.27.3).

Note

PPC4's that have only Gxxx Q-RPTs (no Axxx, BGxxx or utility sensors) are NOT equipped with an on-board barometer.

○ PRINCIPLE

The on-board barometer output can be adjusted using PA and PM values in the same manner as Q-RPTs (see Section 7.2.1.1).

Note

The on-board barometer is a low accuracy sensor used for measuring changes in atmospheric pressure over short periods of time (see Section 3.2.22) and line pressure for G15K and BG15K line pressure compensation. PPC4 measurement uncertainty does not depend on the measurement uncertainty of the on-board barometer.

○ OPERATION

7.3.1 Basic Interface

To edit the values of PA and PM for the barometer, select **<Spec>**, **<Cal>**, **<Barometer>** from the Main Menu. Set the calibration date **[YYYYMMDD]** and edit PA and PM. With security set to **<Off>**, the values can be edited (see Section 3.2.26.5).

[ENTER] to accept changes and return to the Main Run Screen. **[ESC]** to exit to the Main Run Screen and make no changes.

7.3.2 Advanced Interface

To edit the values of PA and PM for the barometer, use **[Settings]**, **<Calibration>**, **Barometer**. Set the calibration date **[YYYYMMDD]** and edit PA and PM. With security set to **Off**, the values can be edited (see Section 3.2.26.5).

[OK] to accept changes and return to the Main Run Screen. **[Back]** to return to **<Calibration>** and make no changes. **[Esc]** or **[ESC]** to exit to the Main Run Screen and make no changes.

7.4 Adjustment of Utility Sensor

○ PURPOSE

To adjust the output of the utility sensor, if present (see Section 1.2.2.2).

○ PRINCIPLE

PPC4s that do not have a Q-RPT in the Internal, Hi position, have a utility sensor.

The utility sensor output can be adjusted using PA and PM values in the same manner as for the Q-RPTs (see Section 7.2.1.1).

Note

- **The utility sensor is not intended to serve as a pressure reference for low uncertainty, traceable measurement. It is for indication, pressure control and system maintenance functions only.**
- **PPC4 measurement uncertainty when using Q-RPTs does not depend on the measurement uncertainty of the utility sensor.**

○ OPERATION

The procedure to adjust the output of the utility sensor is that same as for the calibration of an Internal, Hi (IH), Standard Class, Q-RPT (see Section 7.2.4.1), but the calibration reference uncertainty can be between 0.01 and 0.05 % FS.

7.5 Pneumatic Control Module Configuration

○ PURPOSE

To run an automated routine that adjusts automated pressure control coefficients or to return automated pressure control coefficients to factory default values.

○ PRINCIPLE

PPC4 uses factory configuration coefficients in the pressure control algorithms used for automated pressure control. Changes in the pressure control elements over time or operation into an unusually large test volume can cause pressure control performance to change. The PPC4 on-board configuration routine automatically retunes the factory configuration coefficients to take these changes into account.

The Configuration function should be considered a maintenance function and only used to attempt to improve pressure control when all other factors affecting pressure control have been examined and eliminated (for example leaks, restrictions in test lines, unstable pressure supply, unstable vacuum supply). The configuration function may also be useful to speed up PPC4 pressure control when the minimum test volume is in excess of 500 cc.

In addition, the Configuration function allows pressure control parameters to be returned to factory default values. This feature can be useful to return to known conditions after the on-board configuration function has been run.

Note

- **If the PPC4 Hi Q-RPT or utility sensor is an A350K or lower, the configuration routine should be run twice, once with a vacuum source attached to the EXHAUST port and once without. If the PPC4 Hi Q-RPT or utility sensor is greater than A350K, the configuration routine can be run with or without a vacuum pump connected to the EXHAUST port (use the most common configuration).**

- The default AutoRange of the PPC4 Hi Q-RPT must be active for a Configuration to run. (See Section 5.7.1).

7.5.1 Basic Interface Operation

⚠ Caution

Poor control is usually caused by invalid control parameters, excessive leaks and restrictions in the test system or other set up problems. These problems should be identified and eliminated before resorting to use of the configuration function (see Section 8).

To access the CONFIG function use <Spec>, <Internal>, <Config> in the Main Menu.

<Defaults> causes PPC4 to load factory default control coefficients. This feature can be useful to return to standard conditions if a faulty Configuration routine has been activated or the current configuration is no longer valid.

<Run> causes the pressure control module configuration routine to execute. Before running Configuration, remove any external volume and plug the TEST(+) port. However, if there is a minimum anticipated test volume, for example, the G15K or BG15K DVU (see Section 2.3.7.2), leave the volume connected. Connect the normal supply pressure to the rear panel SUPPLY port and perform a leak check.

If the PPC4 Hi Q-RPT or utility sensor is greater than A350K, proceed directly to the <CAUTION:> screen below. If not, the display is:

```
Config type:
♦Vac ♦Atm
```

Select <Vac> or <Atm> depending on whether the EXHAUST port is at vacuum or atmosphere. If the ControlRef setting (see Section 3.2.27.2) does not correspond to your choice, you will receive an error.

The next display is:

```
CAUTION: About to
set nn MPa g
```

This display warns the user that pressure will increase to roughly 50 % of the Hi Q-RPT default range. **ENTER** to continue if it is safe for PPC4 to set the indicated pressure.

<CFG> flashes in the lower right corner of the display. PPC4 pulses and slews pressure. After about ten minutes, the user is asked whether or not to save the new configuration. If the CONFIG function ran completely and without incident, use <Yes>. <No> to return to the Main Run Screen with no change to the pressure control coefficients.

If the PPC4 has a Hi Q-RPT less than or equal to A350K, repeat the configuration routine in the other **operating** mode (<Vac> or <Atm>). If you never use the PPC4 in one of the two conditions, it is not necessary to configure it in that condition.

⚠ Caution

The configuration routine must be run with NO external volume connected to the PPC4 (TEST(+)) port plugged) unless a known minimum test volume is always connected. After configuring with a volume connected to the TEST(+) port, controlling pressure with a lower volume may result in poor pressure control.

Note

The effect of the Configuration function can be eliminated and control coefficients returned to factory defaults by selecting <Spec>, <Internal>, <Config>, <Defaults>.

7.5.2 Advanced Interface Operation

Caution

Poor control is usually caused by invalid control parameters, excessive leaks and restrictions in the test system or other set up problems. These problems should be identified and eliminated before resorting to use of the configuration function (see Section 8).

To access Control Configuration use **[Tools], <System>, Control Configuration**.

Set Default causes PPC4 to load factory default control coefficients. This feature can be useful to return to standard conditions if a faulty Configuration routine has been activated or the current configuration is no longer valid.

Before running a Configuration, remove any external volume and plug the TEST(+) port. However, if there is a minimum anticipated test volume, for example, the G15K or BG15K DVU (see Section 2.3.7.2), leave the volume connected. Connect the normal supply pressure to the rear panel SUPPLY port and perform a leak check.

To perform a Vacuum Configuration, connect a vacuum pump to the EXHAUST port. If the Control Reference (see Section 3.2.27.2) is not **Vacuum** an error will be displayed.

To perform an Ambient Configuration, make sure there is no vacuum applied to the EXHAUST port. If the Control Reference (see Section 3.2.27.2) is not **Atmosphere** an error will be displayed.

This display warns the user that pressure will increase to roughly 50% of the Hi Q-RPT default range. **[Yes]** to continue if it is safe for PPC4 to set the indicated pressure.

<Running Vacuum configuration> or **<Running ATM configuration>** flashes above a progress bar while the PPC4 pulses and slews pressure. After about ten minutes, the user is asked whether or not to save the new configuration. **[Yes]** if the CONFIG function ran completely and without incident. **[No]** to return to the Main Run Screen with no change to the pressure control coefficients.

If the PPC4 has a Hi Q-RPT less than or equal to A350K, repeat the configuration routine in the other operating mode. If you never use the PPC4 in one of the two conditions, it is not necessary to configure it in that condition.

Caution

- The configuration routine must be run with **NO** external volume connected to the PPC4 (TEST(+) port plugged) unless a known minimum test volume is always connected. After configuring with a volume connected to the TEST(+) port, controlling pressure with a lower volume may result in poor pressure control.
- The effect of the CONFIG function can be eliminated and control coefficients returned to factory defaults by using **[Tools], <Control Configuration>, Set Default**.

7.6 Reloading Embedded Software into Flash Memory

PPC4 uses FLASH memory. This allows the embedded software that controls PPC4 operations and functions to be loaded into PPC4 over its COM1 port from a computer with a simple FLASH loading utility program.

To replace corrupted software or upgrade your software, access the **DHI** worldwide web site at **www.dhstruments.com** and go to **embedded** located under **software**. A Flash loading utility and the latest PPC4 software are available for download at no charge. If you do not have access to the web or have difficulty downloading or loading software, contact your **DHI** representative or a **DHI** Authorized Service Provider for assistance.

If you believe you have discovered an error or “bug” in PPC4 software, please report it with complete details by email to cal.repair@dhinstruments.com or submit an on-line **Quality Feedback Report** at www.dhinstruments.com.

Note

The DHI flash software loading utility and PPC4 embedded software are available for download from DHI web site, www.dhinstruments.com.

7.7 Removing the PPC4 Cover

⚠️ ⚠️ Warning

To avoid electric shock, disconnect mains power before removing the top cover.

In order to access the internal components of the PPC4 it is necessary to remove the chassis cover. To do so, first remove the eight screws that are on the top, right and left edges of the back panel. Then, using the two M3 x 20 mm screws in the PPC4 accessory kit, gradually back the cover from the closed and secured position using both screws. Once the cover is moved back by about 10 mm (0.4 inch) then the screws should be removed or retracted and the cover can be lifted off the chassis (see Figure 29).



Figure 29. Removing Back Cover

7.8 Overhaul

Note

If calibration of the reference pressure transducers (Q-RPT) is included as part of the overhaul procedure, the calibration procedure should be performed last.

Any or all of the following items may be included as part of a system maintenance overhaul:

- Disassemble pressure control module filters and clean filter elements. Replace, if necessary.
- Clean front panel.
- Clean threads of rear panel fittings. Check for damage and replace, if necessary.

- Check that rear panel cooling fan operates when PPC4 is On.
- Check that internal screws, bolts and nuts are tight.
- Verify that internal barometer, if present, reads atmospheric pressure within ± 0.1 kPa (0.015 psi). Adjust if necessary (see Section 7.3)
- Verify that utility sensor, if present, indicates pressure with ± 0.1 % FS over its range. Adjust if necessary (see Section 7.4).
- Pressurize PPC4 to 90 % of maximum pressure and leak test. Select **<Leak>** in the Main Menu for Basic Interface. Use the Leak Test shortcut from the Main Run Screen in the Advanced Interface (see Section 3.2.18). Leak rate, after stabilization, should not exceed 0.001 % of maximum pressure/second.
- Check the PPC4 controls within specifications over its range (see Section 1.2.3).
- Perform calibration of Q-RPTs if necessary (see Section 7.2).

7.9 Subassembly Description and Location

⚠ ⚠ Warning

To avoid electric shock, disconnect mains power before removing the top cover.

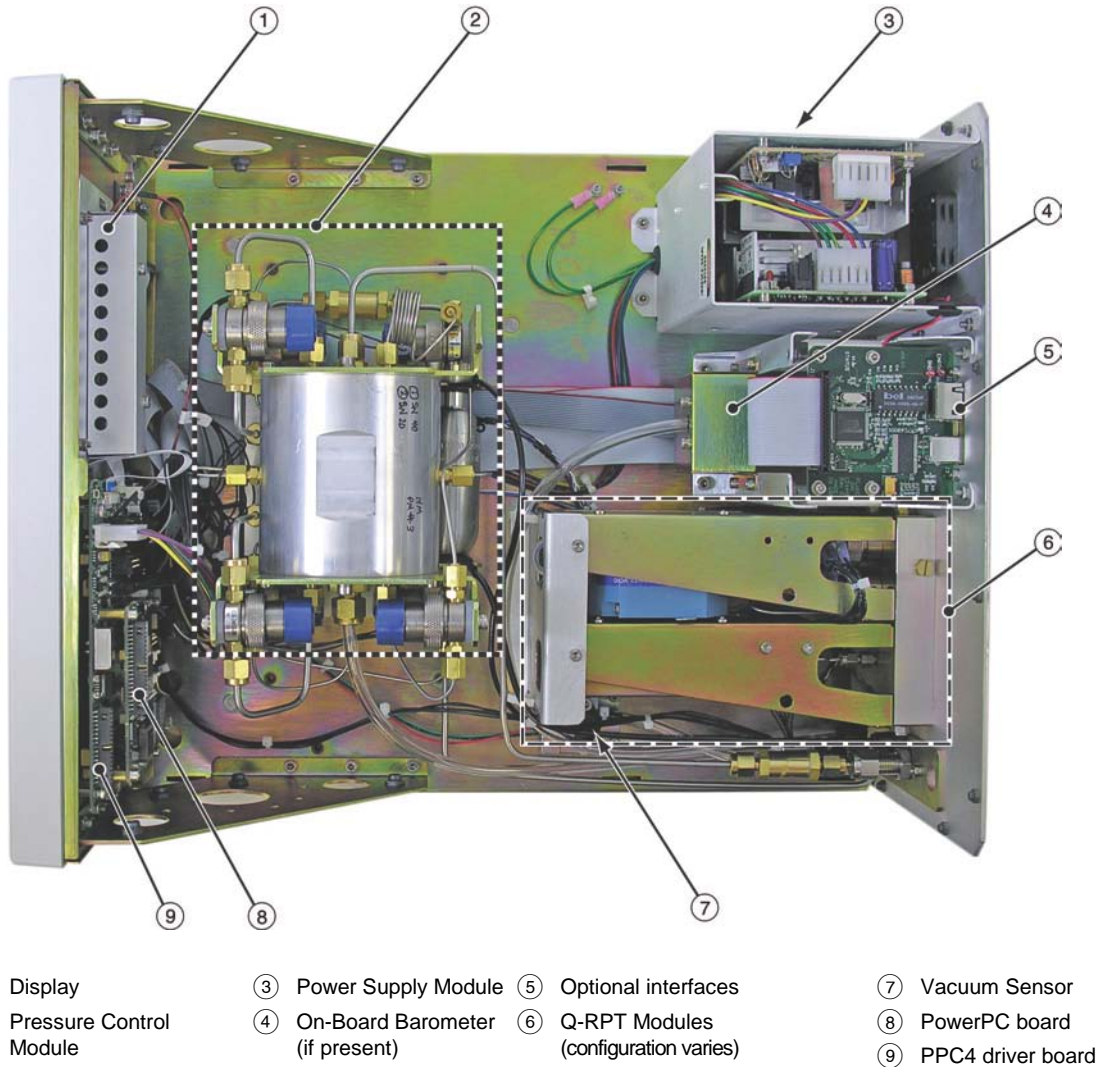

Figure 30. Internal View

7.9.1 Power Supply Module

- + 12 V DC ($\pm 2\%$) @ 3.3 Amps: For internal and external valve actuation.
- + 5 V DC ($\pm 1\%$) @ 3.0 Amps; + 15 V DC ($\pm 3\%$) @ 1.5 Amps; - 15 V DC ($\pm 3\%$) @ 0.35 Amps: For the supply of the micro board and driver board electronics.

7.9.2 PowerPC Board

The PowerPC board supports a Motorola PowerPC 8241 processor, EPROM, EEPROM, 128k x 8 bit NVRAM, 64 Mbit flash memory, 256 Mbit SDRAM memory; RS232 communications; and display control. An FPGA controls other ports and devices in PPC4.

7.9.3 Q-RPT MODULE

The Q-RPT module is an integrated assembly that mechanically manages the PPC4's pressure transducers. The module includes a Hi Q-RPT (quartz reference pressure transducer) or utility sensor and may also have a Lo Q-RPT, brackets to hold the transducer(s) interconnecting tubing, a manifold with the PPC4's **TEST (-)**, **TEST(+)** and **VENT** ports and solenoid valves for AutoZeroing, measurement mode changes and switching of the active transducer.

See Figure 32 for pneumatic schematics of different Q-RPT module configurations.

7.9.3.1 Hi Q-RPT or Utility Sensor

The higher range pressure transducer in a PPC4 may be a Q-RPT (quartz reference pressure transducer) or a utility sensor depending on the specified PPC4 configuration.

A Q-RPT is intended to provide very high precision, low uncertainty, traceable pressure measurement. The basic sensing principle is the measurement of the change in the natural oscillating frequency of a quartz tuning fork in response to changes in temperature and mechanical stress resulting from the change in pressure applied to a connecting bellows or bourdon tube. Two independent quartz elements are used. One quartz element is subjected to pressure related stress. The other quartz element is used only to monitor temperature. See Section 1.2.2.1 for Q-RPT specifications.

The utility sensor is for pressure indication, safety and housekeeping functions. It is a temperature compensated micro-machined silicon sensor module.

7.9.3.2 Lo Q-RPT

PPC4 may be equipped with a Lo Q-RPT. The Lo Q-RPT provides a lower measurement range than the Hi Q-RPT or utility sensor. See Section 7.9.3.1 for a description of Q-RPTs and Section 1.2.2.1 for complete Q-RPT specifications.

7.9.4 On-board Barometer

The on-board barometer supports a board mounted, barometric range, micromachined silicon sensor and an ambient temperature sensor. The barometer readings are used for dynamic atmospheric pressure compensation when measuring gauge pressure with an absolute reference transducer (see Section 3.2.4). The temperature sensor is used for temperature compensation of the barometric sensor.

Note

PPC4s that have Gxxx Q-RPTs (no Axxx, BGxxx or utility sensor) are NOT equipped with an on-board barometer.

7.9.5 Vacuum Sensor

The vacuum sensor is a silicon solid state pressure sensor in the barometric range. The vacuum sensor readings are used to determine whether a atmospheric pressure or a vacuum pressure is applied to the PPC4 **EXHAUST** port (see Section 3.2.27.2).

7.9.6 Pressure Control Module

The pressure control module is an integrated assembly that includes two inlet (fast and slow); two exhaust (fast and slow) control valves; vent valve and differential pressure regulators. The differential pressure regulators use pressure feedback to maintain a constant differential pressure across the control valves. The control valves are solenoid type, actuated by 12 V. See Figure 31 for the pneumatic module schematic.

7.9.7 Display

Basic Interface (PPC4): 2 x 20 character vacuum fluorescent display.

Advanced Interface (PPC4-ui): 5.7" TFT QVGA LCD (320x240).

7.9.8 Driver Board

The driver board is controlled by the PowerPC board (see Section 7.9.2). It supports:

- 12 V drivers for internal and external solenoid valve actuation
- Frequency counters (4) for Q-RPTs (see Section 7.9.3.1)
- On-board barometer power and output (see Section 7.9.4)
- Vacuum sensor power and output for ControlRef function (see Section 3.2.27.2)
- Utility sensor power and output
- Power to the system cooling fan
- Keypad and display
- USB, IEEE-488.2 and TCP/IP communications
- Beeper

7.10 Pneumatic Schematics

7.10.1 Pressure Control Module

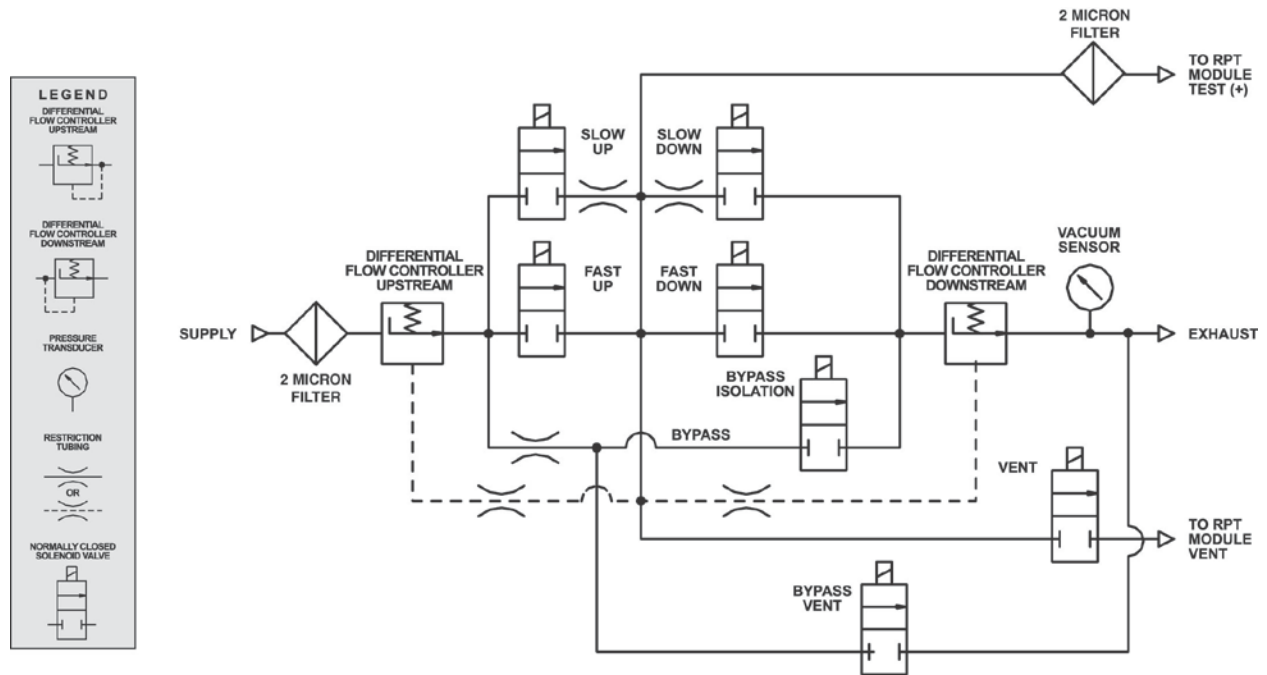

Note

Figure 31. Pressure Control Module Schematic

7.10.2 Q-RPT Module Configurations

ONE Q-RPT-Axxx or utility sensor only (A14M)

CONDITION	VALVE STATE		
	A	B	C
Vent	O	O	O
Measure/Control	C	O	C
Power off	C	O	C

Valve C is shown for reference. It is in the pressure control module.

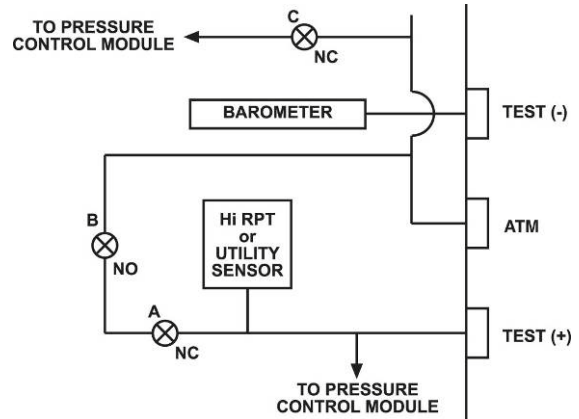

ONE RPT-Axxx or utility sensor (<A14M)

CONDITION	VALVE STATE		
	A	B	C
Vent	O	O	O
Measure/Control	O	C	C
Power off	C	O	C

Valve C is shown for reference. It is in the pressure control module.

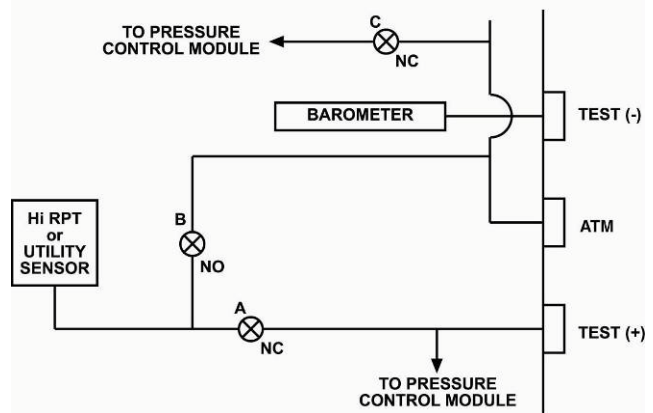

ONE RPT – Gxxx or BGxxx

CONDITION	VALVE STATE			
	A	B	C	D
Vent	O	O	O	O
Measure/Control	O	C	O/C	C
Power off	C	O	O	C

Valve C is the TEST (-) vent valve. In normal operation with BGxxx or Gxxx Q-RPTs, this valve is closed during fine pressure control (see Section 3.5.7.5).

Valve D is shown for reference. It is in the pressure control module.

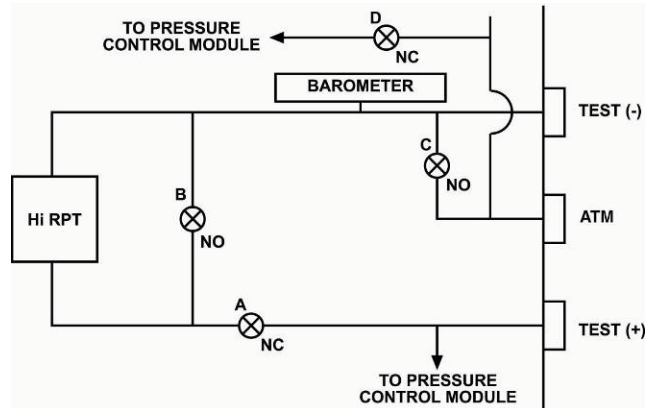

TWO RPTs – No Gxxx or BGxxx

CONDITION	VALVE STATE		
	A	B	C
Vent	O	O	O
Measure/Control Hi	C	O	C
Measure/Control Lo	O	C	C
Power off	C	O	C

Valve C is shown for reference. It is in the pressure control module.

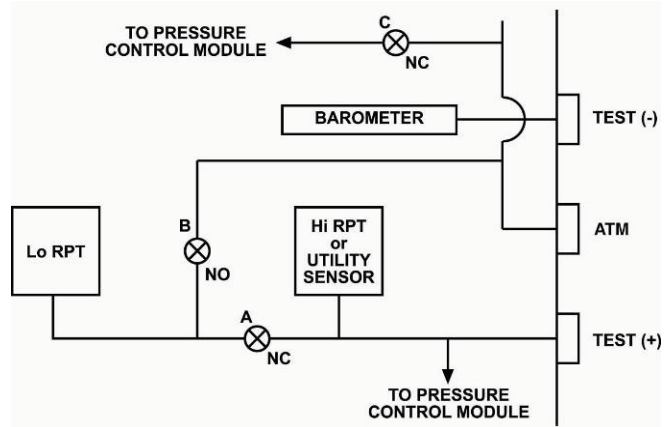

TWO RPTs – One or Two Gxxx or BGxxx

CONDITION	VALVE STATE			
	A	B	C	D
Vent	O	O	O	O
Measure/Control Hi	C	O	C/O	C
Measure/Control Lo	O	C	C/O	C
Power off	C	O	O	C

Valve D is shown for reference. It is in the pressure control module.

Valve C is the TEST (-) vent valve. In normal operation with BGxxx or Gxxx Q-RPTs, this valve is closed during fine pressure control (see Section 3.5.7.5).

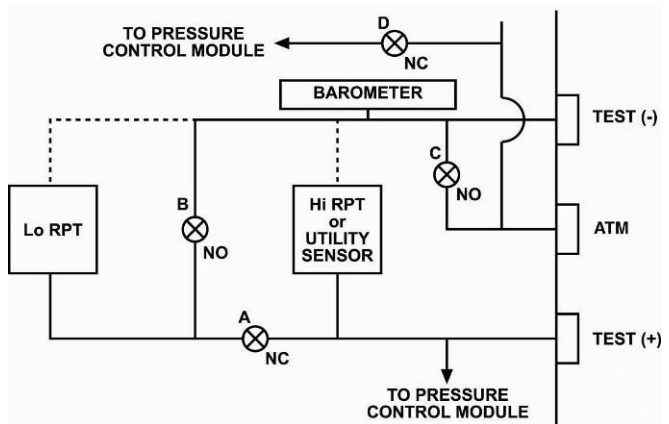

Figure 32. Q-RPT Module Schematics for Various Configurations



8. Troubleshooting

PPC4 is a sophisticated pressure setting and measuring instrument with advanced on-board features and functions. Before assuming that unexpected behavior is caused by a system defect or breakdown, the operator should use this manual and other training facilities to become thoroughly familiar with PPC4 operation. This troubleshooting guide is intended as an aid in identifying the reason for PPC4 behavior and determining whether the behavior is due to normal operation or an internal or external problem.

Identify the symptom or unexpected behavior you are observing from the **SYMPTOM** list below. A **PROBABLE CAUSE** is provided and a **SOLUTION** is proposed including references to manual sections that provide information that may be of assistance.

Table 32. Troubleshooting Guide

SYMPTOM	PROBABLE CAUSE	SOLUTION
Will not power up.	Blown fuse.	Replace fuse.
Cannot access certain functions > ACCESS RESTRICTED <	Security level has been set that restricts access to certain functions.	Change user level or consult system manager. 3.2.26.5
Displays < FATAL ERROR > or < FATAL FAULT >.	Encountered unresolved internal software conflict.	Cycle power to clear. Please record conditions leading up to event including the numbers displayed when ENTER is used. Report to your DHI Authorized Service Provider. Table 36
There is a leak through the PPC4 EXHAUST port.	Normal flow through bypass of internal pressure controllers when pressure supply is connected and system is not vented or OFF.	Operation is normal if flow rate is normal. If there is flow through the EXHAUST port when system is vented or OFF and controller is not a PPC4-10M, contact DHI Authorized Service Representative. 7.8, 3.2.26.5
Front panel keys seem to be disabled.	< remote > command has been sent from a host computer.	Send < local > command from host computer or cycle PPC4 power. 6, 6.5.4
External RPM4 is not being identified when PPC4 is powered up or when an RPT search takes place. PPC4 is unable to find external RPM4 and Q-RPT.	The RPM4 COM1 port settings are not correct.	Set RPM4 COM1 port to settings required for use with PPC4. 2.3.6, 3.2.5
Valve driver #8 seems to be operating erratically without being told to do so.	Driver #8 is used automatically by the automated purge function when purge is activated.	Deactivate purge function or don't use driver #8 other than to support an SPLT. 3.2.17
Measured pressure display has too much/not enough resolution.	Resolution setting needs to be changed.	Use RES function to change the resolution setting. 3.2.19
Can't increase resolution to level desired in AutoRanged range.	Resolution setting is limited when AutoRanging under 10 % of Q-RPT default range.	Operation in normal. Table 5
Values that should be non-zero are displayed as zero.	Resolution setting needs to be increased to view significant digits.	Use Resolution function to change the resolution setting. 3.2.19
The pressure units available under the < Unit > menu are not the ones desired (Basic Interface)	UNIT menu needs to be customized.	Use PresU function to customize the UNIT function or reset units to default. 4.5.6
Front panel display is dim (Basic Interface).	Screen saver option has activated.	Operation is normal. Press any key to resume full screen power. Adjust screen saver time, if desired. 3.2.26.1
Front panel is blank with moving pressure or logo (Advanced Interface)	Screen saver option has activated.	Operation is normal. Press any key to resume full screen power. Adjust screen saver time, if desired. 3.2.26.1

SYMPTOM	PROBABLE CAUSE	SOLUTION
AutoRange is not selecting the desired Q-RPT for the specified range.	The external (RPM4) Q-RPT is not initialized.	Check that the external RPM4 is connected and initialized properly. 2.3.6, 3.2.5
	The Q-RPT range does not cover the desired AutoRange.	Check that Q-RPT default range is high enough to cover the AutoRange. Table 1
	The Q-RPT is Gxxx (gauge only).	Check that the Q-RPT type supports the desired measurement mode. 1.2.2.1, 3.2.11
	The specified operating mode is absolute or negative gauge and absolute mode and negative are OFF for the desired Q-RPT	Check that absolute/negative gauge is ON for the Q-RPT. 3.2.4, 7.2.5
There is a <C> to the right of the <D> or <S> control mode character on the bottom line of the display and it won't go away.	The custom control function has been used.	Reset control parameters to default. 3.2.13
Pressure display is flashing and beeper is sounding intermittently.	Current upper or lower limit of active range has been exceeded.	Correct overpressure condition. Change UL and/or active range if needed. 3.2.21, 3.2.21.1
Pressure display is flashing, no beeper is sounding and direct pressure control keys are inactive.	PPC4 and/or external RPM4 have been over-pressured.	Correct the overpressure condition and cycle power ON and OFF. 3.2.21.1
Display is <Check Xaa aaa RPT, wdog: nnnnn uuuuu> and pressure control is aborted.	PPC4 internal watchdog measurement system has detected that active external Q-RPT does not appear to be connected as its pressure is not changing as expected when PPC4 controls the pressure.	Check that external RPM4 Q-RPT is connected properly to PPC4 TEST(+) port. Cycle PPC4 power. 2.3.6
A <i>Ready</i> (green <i>Ready/Not Ready</i> indicator) indication is never achieved.	Control parameter settings are too tight and/or existing conditions will not allow <i>Ready</i> to be achieved.	Adjust control parameters or correct other conditions. 3.2.3, 3.2.12
Q-RPT is Gxxx (gauge) but cannot select absolute or negative gauge measurement mode.	Q-RPT is Gxxx and does not support absolute and gauge measurement modes or	Operation is normal. 3.2.11
Q-RPT is Axxx (absolute) but cannot select absolute or negative gauge measurement mode.	Absolute and negative gauge measurement modes have been turned off in the calibration function.	Check that absolute/negative gauge is ON. 7.2.5
Will not accept pressure command.	Target exceeds UL and/or current range.	Check UL, range and measurement mode. 3.2.21, 3.2.8, 3.2.11
Will not set pressure.	Pressure and/or vacuum supply incorrectly connected or not adequate.	Correct pressure and/or vacuum supply. 2.3.4, 2.3.5
	There is a very large leak in the test system or TEST(+) port is not connected.	Correct leak. 2.3.8, 3.2.18
Will not set negative gauge pressure.	Measurement mode is not negative gauge.	Set negative gauge mode if supported by Q-RPT. 3.2.11
Poor pressure control at low gauge pressure.	Vacuum source on EXHAUST port is needed.	Connect vacuum source to EXHAUST port. 2.3.5
	Ambient (atmospheric pressure) is too noisy and/or not consistent on TEST (-) port and UUT.	Connect TEST (-) ports of PPC4, RPM4s if present and UUT together and consider isolating from atmospheric pressure. 2.3.7, 2.3.8
Poor pressure control at low gauge and/or absolute pressure.	ControlRef not properly set to reflect pressure conditions at EXHAUST port.	Set Control Reference properly. 3.2.27.2
Poor pressure control at very low gauge pressure.	DVU is needed, particularly if the Q-RPT is a G15K or BG15K.	Install DVU on TEST(+) and TEST (-) ports. 2.3.7.2
Poor pressure control at pressures under atmosphere or inability to reach pressures under atmosphere.	Vacuum supply is incorrectly connected, is not low enough or is unstable.	Correct vacuum supply to EXHAUST port. 2.3.5
Poor pressure control characterized by control interrupting near the target pressure.	Control mode is set to static mode rather than dynamic mode.	Set control mode to dynamic. 3.2.2, 3.2.12

SYMPTOM	PROBABLE CAUSE	SOLUTION
Poor pressure control characterized by excessive overshooting/undershooting and/or "hunting" around target.	There is a restriction in the test connection between the PPC4 and the test or the PPC4, the RPM4 and the test. Restrictions are particularly problematic at low absolute pressures.	Remove the restriction to allow free flow between the PPC4, the RPM4 (if present) and the test. 2.3.7
	Pneumatic control module needs to be reconfigured.	Reconfigure control module after all other possible control issues are considered. 7.5
	The volume connected to the TEST(+) port is too small.	Add volume to the system connected to the TEST(+) port. 1.2.3
	A filter in the PPC4, the SPLT or an accessory is dirty and causing a restriction.	Clean and dry or replace the filter element.
	Excessive leak present in system.	Correct internal or external leak or increase hold limit. 3.2.18, 3.2.13
	Test volume too small.	Increase test volume. Consider use of DVU (Dual Volume Unit) if Q-RPT is G15K or BG15K. Consider reconfiguration of pneumatic module after all other possible control issues have been evaluated. 2.3.7.2, 7.5
Poor pressure control characterized by minor overshooting.	Some overshooting is part of normal operation to speed up pressure stabilization.	Check whether overshooting is within normal limits. Objectively evaluate significance of overshoot relative to UUT span and specifications. Increase test volume.
Poor pressure control characterized by very slow slew rate.	Test volume is too large. Severe restriction in a test line.	Reduce test volume if slew rate is unacceptable. Remove restrictions in line connected to TEST(+) port.
Poor pressure control.	Unstable or incorrect pressure supply.	Connect regulated pressure supply set to correct supply pressure to SUPPLY port. 2.3.4
Poor pressure control and measurement.	The PPC4 and/or the connection to the test system are contaminated with liquids.	Purge and clean affected systems. Consider use of Self-Purging Liquid Trap. Contact DHI Authorized Service Provider if PPC4 is contaminated internally. 2.3.7.1, Table 36
Disagreement between two Q-RPTs in system appears excessive.	Difference is actually within tolerance and acceptable disagreement. Note the Internal, Hi transducer may be a utility sensor which has a much wider tolerance than a Q-RPT.	Compare differences observed to tolerances on Q-RPT and/or utility sensor measurements. 1.2.2.1, 1.2.2.2
Apparent inaccurate pressure control/measure and little or no response from Q-RPT or utility sensor:	Reference transducer destroyed by overpressure.	Contact DHI Authorized Service Provider. Table 36
Apparent inaccurate pressure control/measure when using Internal, Hi (IH) RPT.	The IH transducer is a utility sensor, not a Q-RPT.	Operation is normal for lower specifications of utility sensor. 1.2.2.2
Apparent inaccurate pressure measurement/control.	Incorrect pressure units and/or measurement mode (gauge or absolute).	Set desired pressure units and/or measurement mode. Consider reference temperature if unit is xxH2O. 3.2.10, 3.2.11
	Q-RPT calibration coefficients have been altered.	Check and correct calibration coefficients if needed. 7.2
	AutoZ has been run and turned ON with an incorrect standard for zero.	Check value of P_{offset} . Rerun AutoZ with a valid reference. 3.2.22
Apparent inaccurate pressure measurement/control and <h> is displayed on top line of screen.	An unplanned "head" correction is active or head height or gas is incorrect.	Operation is normal. Remove or change "head" correction. 3.2.16

SYMPTOM	PROBABLE CAUSE	SOLUTION
Will not vent.	System is vented but does not indicate zero because measurement mode is absolute.	Check measurement mode setting and current value of atmospheric pressure if absolute. 3.2.11
	VENT port is plugged.	Open VENT port to atmosphere.
	Vent valve not operating.	Contact DHI Authorized Service Provider. Table 36
Will not vent while purging. Stuck at pressure during purging.	Purge function is not activated, Purge function is activated but no SPLT is connected or SPLT valve is not operating.	Activate SPLT; correct SPLT connection or repair SPLT exhaust valve. 3.2.27.4, 2.3.7.1

9. Appendix

9.1 Drivers

The PPC4 drivers option provides eight open collector drivers for operating external valves, solenoids, indicators, etc.

Each driver outputs 12 V, however the current sinking capacity of each driver is different. Refer to Table 33 for the maximum current of each driver. The total current for all the activated drivers cannot exceed 2 Amps.

Table 33. External Drivers Current Output

DRIVER NUMBER	MAX CURRENT [mA]
1	1 000
2	500
3	500
4	200
5	160
6	135
7	120
8	100

The male connector (P/N 401382) for the **DRIVERS** port is delivered with the PPC4 accessories.

Table 34 and Figure 33 should be referred to when building a cable to utilize the drivers port.

Table 34. External Drivers Pin Outs

EXTERNAL DRIVERS		
PIN	DESCRIPTION	
A	D1	Driver #1 (Open Collector)
C	D2	Driver #2 (Open Collector)
E	D3	Driver #3 (Open Collector)
G	D4	Driver #4 (Open Collector)
M	D5	Driver #5 (Open Collector)
J	D6	Driver #6 (Open Collector)
K	D7	Driver #7 (Open Collector)
L	D8	Driver #8 (Open Collector)
B		Drivers (+ 12 V)
D		Drivers (+ 12 V)
F		Drivers (+ 12 V)
H		Drivers (+ 12 V)

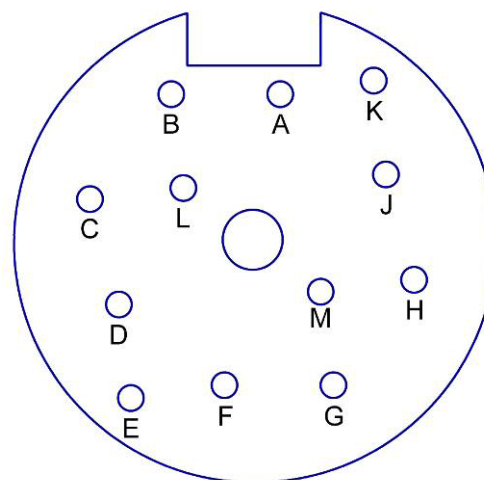

Figure 33. Drivers Connector Schematic

9.2 Unit Conversion

9.2.1 Pressure

PPC4 performs all internal calculations in SI units. Numerical values input or output in other units are converted to SI immediately after entry and back to other units just before output as needed.

Table 30 provides the conversion coefficients used by PPC4 to convert numerical values expressed in SI units to corresponding values expressed in other units.

Table 35. Pressure Unit of Measure Conversion Coefficients

TO CONVERT FROM Pa To		MULTIPLY BY
Pa	<i>Pascal</i>	1.0
mbar	<i>millibar</i>	1.0 E-02
hPa	<i>hecto Pascal</i>	1.0 E-02
kPa	<i>kilo Pascal</i>	1.0 E-03
bar	<i>bar</i>	1.0 E-05
mmH2O @ 4°C	<i>millimeter of water at 4°C</i>	1.019720 E-01
mmH2O @ 20°C	<i>millimeter of water at 20°C</i>	1.019716 E-01
mmH2O @ 60°F	<i>millimeter of water at 60°F</i>	1.018879 E-01
mH2O @ 4°C	<i>meter of water at 4°C</i>	1.019720 E-04
mH2O @ 20°C	<i>meter of water at 20°C</i>	1.019716 E-04
mH2O @ 60°F	<i>meter of water at 60°F</i>	1.018879 E-04
mmHg @ 0°C	<i>millimeter of mercury</i>	7.50063 E-03
psi	<i>pound per square inch</i>	1.450377 E-04
psf	<i>pound per square foot</i>	2.0885429E-02
inH2O @ 4°C	<i>inch of water at 4°C</i>	4.014649 E-03
inH2O @ 20°C	<i>inch of water at 20°C</i>	4.021732 E-03
inH2O @ 60°F	<i>inch of water at 60°F</i>	4.018429 E-03
inHg @ 0°C	<i>inch of mercury</i>	2.953 E-04
kcm ²	<i>kilogram force per centimeter square</i>	1.019716 E-05
mTorr	<i>milliTorr (micron of mercury)</i>	7.50063
Torr	<i>Torr (millimeter of mercury)</i>	7.50063 E-3
user	<i>user</i>	User defined coefficient
ft	<i>feet of altitude</i>	see Altitude Note below
m	<i>meter of altitude</i>	see Altitude Note below

Altitude Note: Quantities expressed in units of altitude follow MIL-STD-859A “Static Pressure, p , in Inches of Mercury for Values of Pressure Altitude, H , in Geopotential Feet.” MIL-STD-859A provides tables of pressure in inches of mercury as a function of altitude in feet. PPC4 uses a set of equations to model the pressure/altitude relationship. The worst case deviation between the MIL-STD-859A table and the calculated pressure is 0.0001 inches of mercury (0.3 Pa). The pressure quantity expressed in inches of mercury is converted to Pascal following Table 30 above. For altitude expressed in meters, meters are converted to feet using $1\text{ m} = 3.28084\text{ ft}$.



10. Warranty

10.1 Overview

Except to the extent limited or otherwise provided herein, **DH Instruments, a Fluke Company** warrants for one year from purchase, each new product sold by it or one of its authorized distributors, only against defects in workmanship and/or materials under normal service and use. Products which have been changed or altered in any manner from their original design, or which are improperly or defectively installed, serviced or used are not covered by this warranty.

DH Instruments, a Fluke Company and any of its Authorized Service Providers' obligations with respect to this warranty are limited to the repair or replacement of defective products after their inspection and verification of such defects. All products to be considered for repair or replacement are to be returned to **DH Instruments, a Fluke Company** or its Authorized Service Provider after receiving authorization from **DH Instruments, a Fluke Company** or its Authorized Service Provider. The purchaser assumes all liability vis a vis third parties in respect of its acts or omissions involving use of the products. In no event shall **DH Instruments, a Fluke Company** be liable to purchaser for any unforeseeable or indirect damage, it being expressly stated that, for the purpose of this warranty, such indirect damage includes, but is not limited to, loss of production, profits, revenue, or goodwill, even if **DH Instruments, a Fluke Company** has been advised of the possibility thereof, and regardless of whether such products are used individually or as components in other products.

The provisions of this warranty and limitation may not be modified in any respect except in writing signed by a duly authorized officer of **DH Instruments, a Fluke Company**

The above warranty and the obligations and liability of **DH Instruments, a Fluke Company** and its Authorized Service Providers exclude any other warranties or liabilities of any kind.

Table 36. DHI Authorized Service Providers

DH INSTRUMENTS, A FLUKE COMPANY AUTHORIZED SERVICE PROVIDERS			
COMPANY	ADDRESS	TELEPHONE, FAX & EMAIL	NORMAL SUPPORT REGION
DH Instruments, a Fluke Company	4765 East Beautiful Lane Phoenix AZ 85044-5318 USA	Tel 602.431.9100 Fax 602.431.9559 cal.repair@dhinstruments.com	Worldwide
Minerva Meettechniek B.V.	Chrysantstraat 1 3812 WX Amersfoort the NETHERLANDS	Tel (+31) 33.46.22.000 Fax (+31) 33.46.22.218 info@minervaipm.com	European Union
Ohte Giken, Inc. Technology Center	258-1, Nakadai, Kasumigaura-machi, Niihari-Gun Ibaraki, 300-0133 JAPAN	Tel 81.29.840.9111 Fax 81.29.840.9100 tech@ohtegiken.co.jp	Japan/Asia
DHI Products Technical Service Division	National Institute of Metrology Heat Division Pressure & Vacuum Lab NO. 18, Bei San Huan Donglu Beijing 100013 PR CHINA	Tel 010.64291994 ext 5 Tel 010.64218637 ext 5 Fax 010.64218703 cxcen@mx.cei.gov.cn	Peoples Republic of China

Notes



11. Glossary

Axxx	A type of Q-RPT with a built-in vacuum reference that is intrinsically absolute (e.g. A10M). Axxx Q-RPTs support absolute, gauge and negative gauge measurement modes.
Absolute Mode	Measurement mode in which the Q-RPT indicates absolute pressure (difference from vacuum).
AutoRange	A function that optimizes PPC4 measurement and control for a specific, user defined range of operation.
AutoRanged Range	A PPC4 range created using the AutoRange function.
AutoTest or ATest	PPC4 on-board automated testing sequences and their results.
AutoZero or AutoZ	A process by which a Q-RPT and measurement mode is rezeroed (offset) relative to a standard.
Barometer	PPC4's on-board atmospheric pressure measuring sensor. Also referred to as on-board barometer.
BGxxx	A type of Q-RPT that is intrinsically gauge and is capable of operating bi-directionally, above and below atmosphere, through zero). BGxxx Q-RPTs support gauge and negative gauge measurement modes.
Bi-directional Gauge	Measurement mode in which the Q-RPT indicates gauge pressure (difference from atmospheric pressure), in both positive and negative directions (above and below atmosphere)
Cockpit	PPC4 accessory software that runs on a PC a PC and emulates the Advanced Interface front panel. When the PC is connected to the PPC4 basic or PPC4-ui, Cockpit gives full Advanced Interface capability through the PC window. (see Section 6.2)
Control Mode	Type of automated pressure control (static or dynamic).
Control Parameters	Parameters affecting pressure control and the <i>Ready/Not Ready</i> determination (target, hold limit, stability limit).
Custom Control	Automated pressure control in which the control parameters are not the default control parameters.
Default Range (DF)	A Q-RPT or utility sensor's maximum range that is always available on [RANGE] and cannot be deleted.
Deviation	The deviation of the current pressure from the target pressure control value. Indicated in Main Run Screen when in dynamic control mode.
DUT	Device Under Test. The device or devices pneumatically connected to the PPC4 TEST port that the PPC4 is being used to test or calibrate. (see also UUT)
Dynamic Control	Control mode in which the pressure is constantly adjusted to remain as close as possible to the target value.
External device or External Q-RPT	A Q-RPT in an RPM4 external to PPC4 used by PPC4 for precise pressure measurement.
FS	Abbreviation of "full scale". The full scale value is the maximum pressure or the span of a measurement range. Limits and specifications are often expressed as % FS.
Gxxx	A type of Q-RPT that is intrinsically gauge but only measures pressure greater than atmosphere. Gxxx Q-RPTs support gauge measurement mode only.
Gauge Mode	Measurement mode in which the Q-RPT indicates gauge pressure (difference from atmospheric pressure), but only in the positive direction (above atmosphere).
Head	A difference in height between the PPC4 reference level and the DUT.
Hold Limit	An automated pressure control parameter. Maximum acceptable difference between the current pressure and the target pressure value.
IH or IuH	Internal, Hi. The Q-RPT (IH) or utility sensor (IuH) internal to PPC4 if there is only one or, if there are two, the one that has the highest full scale default range.
IL	Internal, Lo. Refers to a Q-RPT internal to the PPC4 that is the lower of the two if there is a second Q-RPT or utility sensor in the PPC4.
Measurement Mode	Whether pressure is being measured relative to absolute zero or vacuum (absolute mode) or relative to atmospheric pressure (gauge mode).

Negative gauge, compound gauge	Measurement mode in which the Q-RPT indicates gauge pressure (difference from atmospheric pressure), in both positive and negative directions (above and below atmosphere).
P_{offset}	The difference between a Q-RPT reading and the AutoZero reference at the time AutoZ is run. Used by the AutoZ function when Auto Z is ON to compensate Q-RPT readings for changes in zero over time.
P_{std,0}	AutoZero reference value. Value indicated by the device against which the Q-RPT is zeroed by AutoZ.
PA	Pressure adder, used to offset a Q-RPT, utility sensor or barometer to calibrate it.
PM	Pressure multiplier, used to adjust span of a Q-RPT, utility sensor or barometer to calibrate it.
Q-RPT (Reference Pressure Transducer)	<ol style="list-style-type: none"> 1. The transducer used by PPC4 for low uncertainty pressure measurement. The Q-RPT in a single Q-RPT PPC4, or the higher pressure range Q-RPT in a dual Q-RPT PPC4, is referred to as the Hi or Q-RPT. 2. The lower pressure range Q-RPT in a dual Q-RPT PPC4 is referred to as the Lo Q-RPT. <p>Q-RPTs are designated by a leading A, G or BG (absolute, gauge or bi-directional gauge) followed by three numbers and a letter indicating the maximum range of the Q-RPT in kPa (nnnK) or MPa (nnnM).</p>
Rate	The rate of change of the current measured pressure. Indicated in the Main Run Screen when control is suspended.
Ready/Not Ready	Indication used to indicate when control PPC4 pressure meets specific criteria for distance from target pressure and stability. <i>Ready/Not Ready</i> is indicated by an LED on the PPC4 front panel and is used to determine when test readings should be taken.
RPM4	Reference Pressure Monitor manufactured by DHI . RPM4s can be set up to act as external measurement devices to operate with PPC4.
Span	The difference between FS and the lowest point in a range. For example, the span of a 100 kPa FS range in negative gauge mode is nominally 200 kPa (from - 100 kPa to 100 kPa).
SPLT	Self Purging Liquid Trap. An optional device to automatically protect PPC4 from liquid and particulate contamination returned from a DUT.
Stability Limit	A limit expressed in units of pressure per second (e.g., kPa/second). The stability limit is used as the <i>Ready/Not Ready</i> criterion. <i>Ready</i> if rate of change is less than stability limit. <i>Not Ready</i> if rate of change is greater than stability limit.
Static Control	Control mode in which the pressure is set near the target value and then shut OFF and allowed to evolve freely.
Target	The value to which automated pressure control sets and maintain the pressure.
UL	Same as Upper Limit.
Upper Limit	A range specific maximum value of pressure not be exceeded and at which PPC4 will abort pressure setting and beep. In negative gauge measurement mode there is also a lower limit.
Utility Sensor	The internal, high (luH) transducer in a PPC4 if when there is no Q-RPT in the IH position. A utility sensor is a low accuracy pressure transducer used for pressure indication, safety and housekeeping functions, not for low uncertainty measurement.
UUT	Unit Under Test. The unit or units pneumatically connected to the PPC4 TEST port that the PPC4 is being used to test or calibrate.
User Level	Levels of security that can be set to protect certain PPC4 functions from being accessed.
X1H, X1L	<p>External, Hi; External Lo: Position designators of Q-RPTs external to a PPC4 (in RPM4s) that have been connected to PPC4 and initialized so that they can be used by PPC4 for pressure measurement.</p> <p>“1” is the first RPM4 in the communications daisy chain. PPC4 does not support 2 remote RPM4 configurations.</p> <p>“Hi” is the Q-RPT in the RPM4 if there is only one or the one that has the highest full scale default range if there are two.</p> <p>“Lo” is the lower of the two Q-RPTs if there are two Q-RPTs in the RPM4.</p>