

P5514, P5514-V & P5514-EP

Hydraulic Comparison Test Pump

Users Manual

LIMITED WARRANTY AND LIMITATION OF LIABILITY

Each Fluke product is warranted to be free from defects in material and workmanship under normal use and service. The warranty period is one year and begins on the date of shipment. Parts, product repairs, and services are warranted for 90 days. This warranty extends only to the original buyer or end-user customer of a Fluke authorized reseller, and does not apply to fuses, disposable batteries, or to any product which, in Fluke's opinion, has been misused, altered, neglected, contaminated, or damaged by accident or abnormal conditions of operation or handling. Fluke warrants that software will operate substantially in accordance with its functional specifications for 90 days and that it has been properly recorded on non-defective media. Fluke does not warrant that software will be error free or operate without interruption.

Fluke authorized resellers shall extend this warranty on new and unused products to end-user customers only but have no authority to extend a greater or different warranty on behalf of Fluke. Warranty support is available only if product is purchased through a Fluke authorized sales outlet or Buyer has paid the applicable international price. Fluke reserves the right to invoice Buyer for importation costs of repair/replacement parts when product purchased in one country is submitted for repair in another country.

Fluke's warranty obligation is limited, at Fluke's option, to refund of the purchase price, free of charge repair, or replacement of a defective product which is returned to a Fluke authorized service center within the warranty period.

To obtain warranty service, contact your nearest Fluke authorized service center to obtain return authorization information, then send the product to that service center, with a description of the difficulty, postage and insurance prepaid (FOB Destination). Fluke assumes no risk for damage in transit. Following warranty repair, the product will be returned to Buyer, transportation prepaid (FOB Destination). If Fluke determines that failure was caused by neglect, misuse, contamination, alteration, accident, or abnormal condition of operation or handling, including overvoltage failures caused by use outside the product's specified rating, or normal wear and tear of mechanical components, Fluke will provide an estimate of repair costs and obtain authorization before commencing the work. Following repair, the product will be returned to the Buyer transportation prepaid and the Buyer will be billed for the repair and return transportation charges (FOB Shipping Point).

THIS WARRANTY IS BUYER'S SOLE AND EXCLUSIVE REMEDY AND IS IN LIEU OF ALL OTHER WARRANTIES, EXPRESS OR IMPLIED, INCLUDING BUT NOT LIMITED TO ANY IMPLIED WARRANTY OF MERCHANTABILITY OR FITNESS FOR A PARTICULAR PURPOSE. FLUKE SHALL NOT BE LIABLE FOR ANY SPECIAL, INDIRECT, INCIDENTAL, OR CONSEQUENTIAL DAMAGES OR LOSSES, INCLUDING LOSS OF DATA, ARISING FROM ANY CAUSE OR THEORY.

Since some countries or states do not allow limitation of the term of an implied warranty, or exclusion or limitation of incidental or consequential damages, the limitations and exclusions of this warranty may not apply to every buyer. If any provision of this Warranty is held invalid or unenforceable by a court or other decision-maker of competent jurisdiction, such holding will not affect the validity or enforceability of any other provision.

Fluke Corporation
P.O. Box 9090
Everett, WA 98206-9090
U.S.A.

Fluke Europe B.V.
P.O. Box 1186
5602 BD Eindhoven
The Netherlands

11/99

To register your product online, visit register.fluke.com

Table of Contents

Title	Page
Preparation	1
How to Contact Fluke	1
Operating Fluid Compatibility	2
Safety Information	2
Compressed Liquid	2
Personal Protective Equipment	2
Symbols Used in this Manual	2
Connections	3
Connect the Gauge	4
Connect the Test Port Insert	4
Operation	5
Priming	5
Operation	6
Maintenance and Servicing	6
Screw Press Seals	6
Complete Disassembly	7
Ancillary Equipment	11
Angle Adapter, P5543	11
Pointer Remover/Punch, P5551	11

List of Tables

Table	Title	Page
1.	Operating Fluid Compatibility	2
2.	Symbols.....	3
3.	Test Port Insert - Parts List.....	5
4.	Seal Kit - Part Numbers	6
5.	Screw Press Assembly - Parts List.....	10

List of Figures

Figure	Title	Page
1.	Connecting the Gauge	4
2.	Test Port Insert	5
3.	Reservoir and Test Port Assemblies.....	9
4.	Screw Press Assembly	9
5.	Angle Adapter	11
6.	Pointer Remover/Punch.....	11

Preparation

The Hydraulic Comparison Test Pump User's Manual covers the following instruments: the P5514, P5514-V, and the P5514-EP.

The Comparison Test Pump is used for checking pressure-measuring instruments against Master Test Gauges.

Note

The terms "Master Test Gauge" and "Gauge" in this document refer to any pressure-measuring instrument such as Transfer Standards, Digital Calibrators, and Transducers.

This system is only as accurate as the Master Test Gauge used. The Master Test Gauge must be regularly calibrated on a Primary Reference Standard (such as a Deadweight Tester) to ensure accuracy is maintained.

The comparison test pump should be mounted securely to a stable workbench or similar surface. Four mounting holes are provided in the pump stand for this purpose.

How to Contact Fluke

To order accessories, receive operating assistance, or get the location of the nearest Fluke distributor or Service Center, call:

- Technical Support USA: 1-800-99-FLUKE (1-800-993-5853)
- Calibration/Repair USA: 1-888-99-FLUKE (1-888-993-5853)
- Canada: 1-800-36-FLUKE (1-800-363-5853)
- Europe: +31-402-675-200
- China: +86-400-810-3435
- Japan: +81-3-3434-0181
- Singapore: +65-738-5655
- Anywhere in the world: +1-425-446-5500

Or, visit Fluke's website at www.fluke.com.

To register your product, visit <http://register.fluke.com>.

To view, print, or download the latest manual supplement, visit <http://us.fluke.com/usen/support/manuals>.

Operating Fluid Compatibility

The standard system is designed for use with a wide range of fluids; however, the O-ring seals are Nitrile; use of solvents, fuel oils, brake fluids or other, similar aggressive fluids can damage the seals. The table below details the two alternative versions of this instrument, which offer increased compatibility with other fluids.

Table 1. Operating Fluid Compatibility

Model	O Rings
P5514	Nitrile
P5514-V	Viton
P5514-EP	Ethylene Propylene

Rotate reservoir dust cover through ½ turn and fill reservoir approximately ¾ full with the appropriate fluid. Rotate dust cover back to cover reservoir.

⚠ Caution

To avoid damage to the instrument, the operator should check the quality of the operating fluid during use. If the fluid becomes discolored, cloudy or particles appear in the reservoir, the system should be drained and flushed with clean fluid.

Safety Information

The following are general safety precautions that are not related to any specific procedures and do not appear elsewhere in this publication. These are recommended precautions that personnel must understand and apply during equipment operation and maintenance to ensure safety and health and protection of property.

Compressed Liquid

Use of compressed liquids can create an environment of propelled foreign matter. Pressure system safety precautions apply to all ranges of pressure. Care must be taken during testing to ensure that all hydraulic connections are properly and tightly made prior to applying pressure. Personnel must wear eye protection to prevent injury.

⚠ Warning

If the equipment is used in a manner not specified by the manufacturer, the protection provided by the equipment may be impaired.

Personal Protective Equipment





Wear eye protection approved for the materials and tools being used.

Symbols Used in this Manual

In this manual, a **Warning** identifies conditions and actions that pose a hazard to the user. A **Caution** identifies conditions and actions that may damage the Hydraulic Comparison Test Pump.

Symbols used on the Hydraulic Comparison Test Pump and in this manual are explained in Table 2.

Table 2. Symbols

Symbol	Description
	AC (Alternating Current)
	Earth Ground
	Important Information: refer to manual
	Do not dispose of this product as unsorted municipal waste. Go to Fluke's website for recycling information.

Connections

Fit the device under test (DUT) to the test port using the method described below:

Caution

Ensure that all devices are internally clean and free from contamination before connecting to the tester.

Particle contamination can damage the sensitive piston assemblies, valve seats, and screw pump.

To avoid cross-contamination from other fluids and protect the system from particulates, we recommend the use of a Liquid-to-Liquid Separator (see Section 5, Ancillary Equipment).

Warning

DO NOT use Teflon/PTFE tape on these connections as this will prevent correct sealing. The Gauge Adapter sealing system is designed for hand-tight sealing up to 20,000 psi / 1,400 bar-wrenches or similar tools are not required — over tightening can cause damage to threads or sealing faces.

Before connection, ensure that there is an O-ring fitted to the test port.

Check that the sealing face of the device to be fitted is clean and undamaged, as scratches or dents can form leak-paths.

Note

The thread on the test port, and the lower part of the gauge adapters is LEFT-HANDED. The following procedure details the correct method for mounting devices using these adapters.

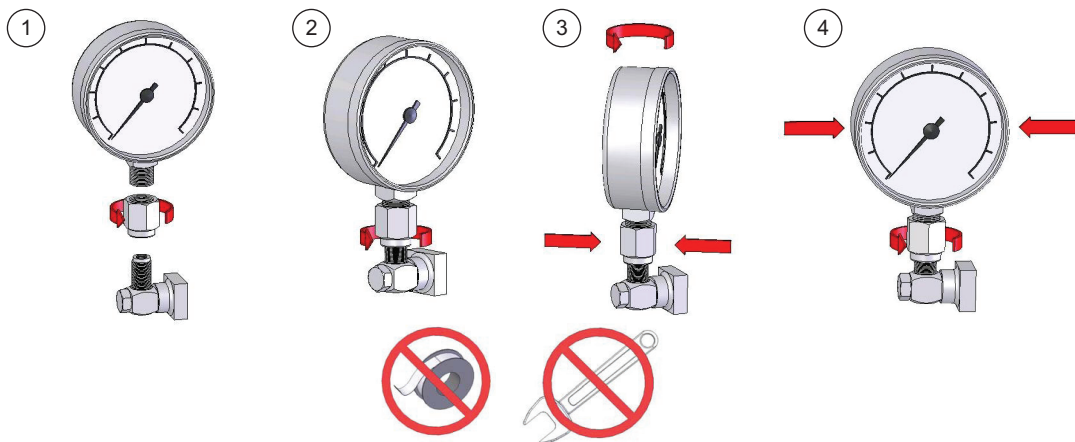

Figure 1. Connecting the Gauge

gjq001.eps

Connect the Gauge

Refer to Figure 1 for steps 1 to 4.

1. Screw the appropriate gauge adapter fully on to the instrument to be tested.
2. Screw assembly down COUNTER-CLOCKWISE on to test port.

Note

Hand-tight is sufficient; ensure that the bottom face contacts the O-ring on the test port.

3. To adjust the position to face forward, hold the gauge adapter and turn the instrument COUNTER-CLOCKWISE, so that it faces forward.
4. Hold the instrument steady, while turning the gauge adapter COUNTER-CLOCKWISE until it pulls down onto the O-ring.

Connect the Test Port Insert

For devices with 1/8 BSP or NPT mounting threads, the diameter of the thread is very close to the effective sealing diameter of the O-ring fitted to the test port.

This can make it difficult to achieve a good seal. When mounting these devices, use the test port insert (stored in the spare seals container) as shown Figure 2.

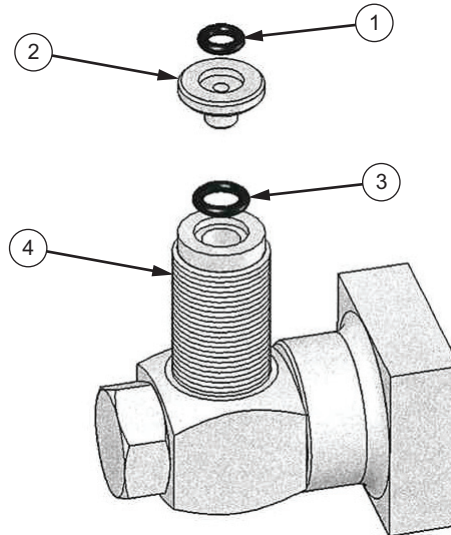

Figure 2. Test Port Insert

gjq002.eps

Table 3. Test Port Insert - Parts List

Item	Description	P5515	P5515-V	P5515-EP
1	O Ring	3865142	3865163	3867888
2	Test Port Insert	3919892	—	—
3	O Ring	3883397	3883521	3867895
4	Test Port	3918298	—	—

To calibrate panel-mounted gauges with pressure connections in the rear, use an Angle Adapter (see Ancillary Equipment section).

Operation

Priming

1. Open reservoir valve (13) one turn counter-clockwise and turn screw press fully in.
2. Close valve (13) and turn screw press fully out.
3. Open valve and turn screw press fully in.

Note

During this operation, bubbles may appear in the reservoir, as trapped air is expelled. For large volumes, repeat steps 2 and 3 until no further bubbles appear.

4. With valve open, turn screw press fully out and close valve. The test pump is now ready for use.

⚠ Warning

Turning the capstan out with the reservoir valve closed will generate approximately 15 inHg / 0.5 bar vacuum. If the DUT is vacuum sensitive, leave valve (13) open during priming operation.

Operation

⚠ Warning

Do not exceed the maximum working pressure of the instrument (stated on the instrument label).

1. Turn the screw press in to generate pressure.
2. Allow a few moments for the system to stabilize before taking any readings, especially after large changes in system pressure.

Note

Large, sudden changes in pressure will cause the system temperature to rise or fall, which can cause instrument readings to change as the fluid in the system expands or contracts, thus increasing or decreasing the pressure.

3. Compare the reading of the gauge under test with that of the master gauge.
4. For the next higher calibration point, repeat from Priming, Step 1.
5. To measure reducing pressures, turn the screw press out (counter-clockwise).
6. Depressurize the system by turning the screw press FULLY OUT, then open the reservoir valve

⚠ Caution

Never release the system pressure by using the reservoir valve alone, as sudden depressurization will “shock” the system, which may cause damage to sensitive instruments attached to it.

Maintenance and Servicing

The Figures on the following pages detail the components of each assembly, together with the relevant part numbers. Where “ASSY” appears as a part number, this indicates that this particular component is associated with other components in an assembly for replacement purposes.

Before beginning any maintenance, remove any instruments that may be mounted to the test pump, and drain the fluid from the system.

Table 4. Seal Kit - Part Numbers

Model	Seal Kit P/N
P5514	3891113
P5514-V	3891124
P5514-EP	3891136

Screw Press Seals

1. Turn the screw press out so that there is a distance of at least 1” / 2.5cm between the large union nut at the end of the barrel and the capstan hub.
2. Unscrew the union nut and withdraw the lead screw assembly (24) from the barrel, taking care not to drop the rambler (22).
3. Inspect the seals for signs of wear or damage, replace as necessary.

4. The white, anti-extrusion ring (21) is a PTFE spiral, and can be removed by “unwinding” it from the rambler.
5. When removing the rambler seal (20), take care not to use any tool that may have a sharp edge that will scratch the surfaces of the rambler, otherwise it may leak when reassembled.
6. The replacement rambler seal can be eased over the front of the rambler, and into the groove.
7. Similarly, the new anti-extrusion ring can be “wound” into the groove in the rambler, behind the rambler seal.
8. If the rambler has been separated from the lead screw, ensure that the ball (23) is correctly fitted before reassembly.
9. Ensure that the rambler assembly is correctly located on the end of the lead screw assembly. Carefully introduce the rambler into the open end of the barrel; making sure that it does not tilt when entering the barrel.
10. Push the lead screw assembly fully in to the barrel, ensuring that the key in the nut locates correctly in the slot in the barrel.
11. Re-tighten the barrel union nut.

⚠ Caution

If the lead screw assembly (24) shows signs of excessive wear, then it is very likely that the associated components have worn also; therefore, the screw press assembly is available as a spare part.

Complete Disassembly

1. Remove the screw press assembly as described above.
2. Unscrew and remove valve stem (13), taking care not to lose spring (12) and nylon washer (11).
3. Remove reservoir cover (10).
4. Unscrew locknut (9), and remove reservoir (8).
5. Unscrew valve body (6), taking care not to lose bonded seal (7) or O-ring (5).
6. Remove banjo bolts (1), together with banjo test ports (3), taking care not to lose O-rings (2).
7. Disconnect the stand (15) from the bench. Remove screws (14), and tilt manifold/barrel assembly downward and pass it out of the bottom of the stand.
8. To remove the barrel (19), the locknut (18) must be loosened approximately 1/2 turn. The barrel can then be unscrewed from the manifold (16).
9. Before re-fitting the barrel, ensure that the barrel seal (17) is correctly located in the counter-bore in the front of the barrel. Screw the barrel fully in to the test station, and secure with the locknut.
10. Inspect all seals for wear or damage — replace as necessary.

⚠ Caution

If the rambler shows signs of wear, then it is very likely that the main bore in the barrel is worn also. If the bore is worn or scratched, it will not seal correctly, and may leak under pressure.

11. Re-assembly is the reverse of the above. Ensure that all seals and sealing surfaces are clean and undamaged.

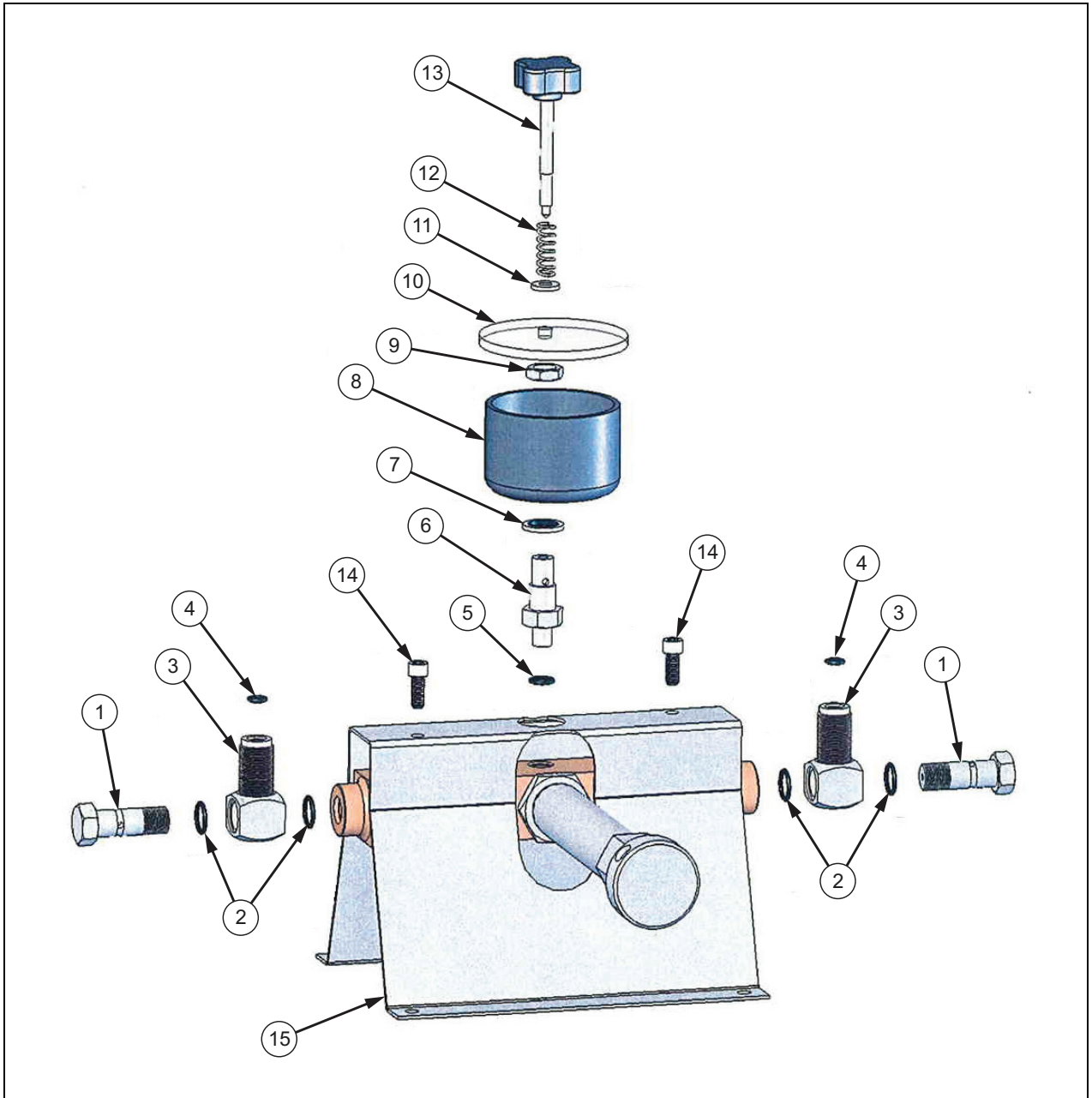

Figure 3. Reservoir and Test Port Assemblies

gj003.eps

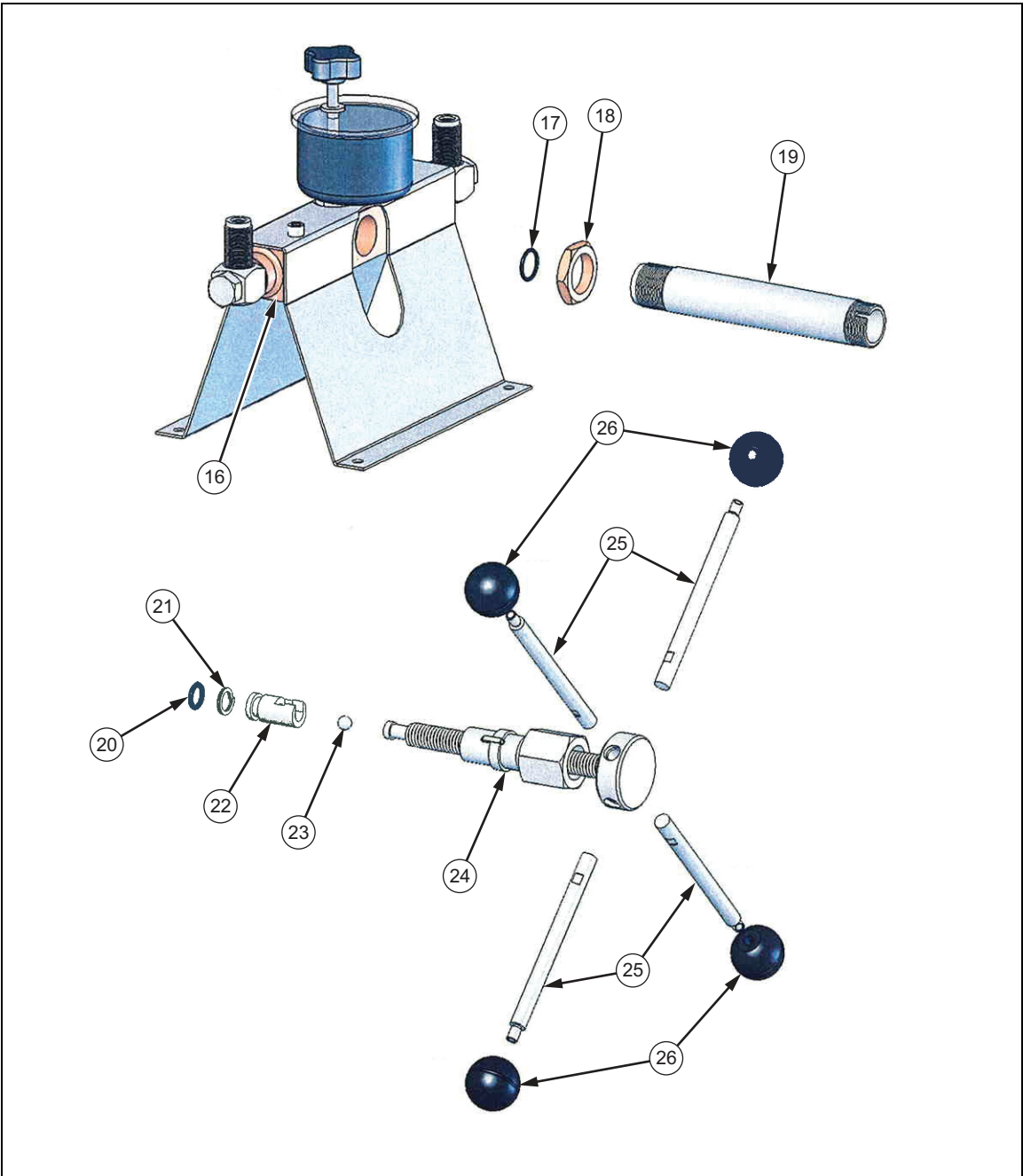

Figure 4. Screw Press Assembly

gj004.eps

Table 5. Screw Press Assembly - Parts List

Item	Description	Part		
		P5514	P5514-V	P5514-EP
1	Banjo Bolt	3918323	—	—
2	O Ring	3905652	3919393	3926936
3	Banjo Test Port	3918298	—	—
4	O Ring	3883397	3883521	3867895
5	O Ring	3864857	3865277	3921986
6	Valve Body	3923785	—	—
7	Bonded Seal	3862349	3922096	3922043
8	Reservoir	3919463	—	—
9	Locknut	3918244	—	—
10	Reservoir Cover	3918350	—	—
11	Washer	3916458	—	—
12	Spring	3922786	—	—
13	Valve Stem Assembly	3885982	—	—
14	Screw	3909422	—	—
15	Pump Stand	3918271	—	—
16	Manifold	3918280	—	—
17	O Ring	3864711	3865359	3865576
18	Locknut	3917862	—	—
19	Barrel	3919630	—	—
20	O Ring	3864782	3865214	3865541
21	Back-Up Ring	3920516	—	—
22	Rambler	3919611	—	—
23	Ball	3917855	—	—
24	Lead Screw Assembly	3885982	—	—
25	Spoke	3921672	—	—
26	Knob	3917843	—	—

Ancillary Equipment

Angle Adapter, P5543

To calibrate gauges with the pressure connection on the rear (e.g. panel-mount gauges) in their correct position, an angle adapter should be used. The angle adapter fits directly onto the test station, converting it through 90 degrees, allowing the standard adapters to be used.

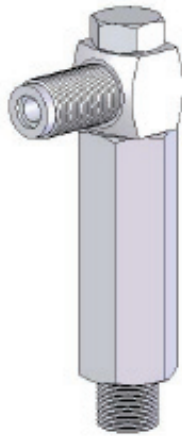

Figure 5. Angle Adapter

gjn022.bmp

Pointer Remover/Punch, P5551

To remove and refit the pointer of a pressure gauge, use the pointer remover/punch instrument. This tool has a spring-loaded plunger to quickly and consistently refit the pointer.



Figure 6. Pointer Remover/Punch

gjn023.bmp

